



CORNELL PUMP COMPANY

3NLP Food Handling Pump

PUMP SPECIFICATION

- 3NLP-F5K Frame mounted food handling pump
- 3" x 3" Class 125 Flanged suction and discharge
- Constructed of ASTM A48, Class 30 Cast Iron
- 6.5" impeller diameter
- 2" diameter by 3" length solid food handling characteristics
- Food grade packing
- Industry leading two year warranty
- Variable operating speed
- Optional mounting configurations available

FEATURES & BENEFITS

- **Cornell's Patented Pump Design**
 - significantly reduces product damage and abrasion
- **Single Port Impeller**
 - proven feature designed specifically for handling whole or processed foods
- **Offset Volute**
 - food passes through center of discharge nozzle without contacting volute wall
- **Cycloseal® Option**
 - self-contained single mechanical seal
 - requires no external flush
 - pressure gradients move solids away from seal faces
- **Quality Materials**
 - other materials of construction available for abrasive or caustic applications

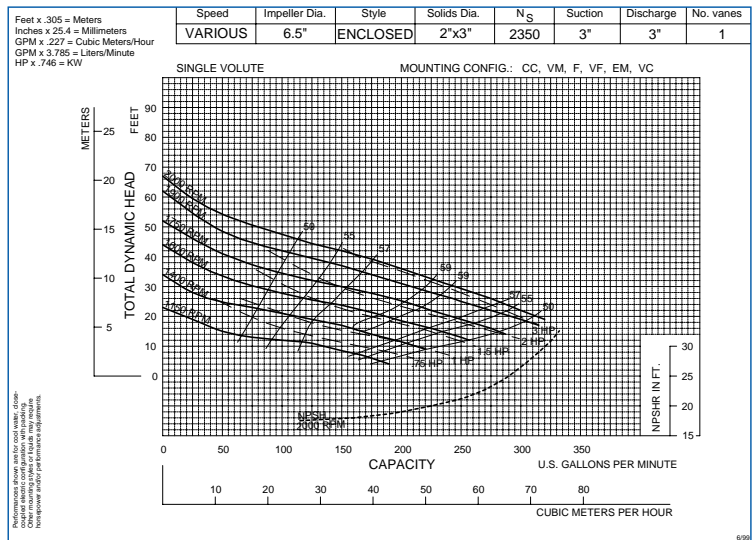

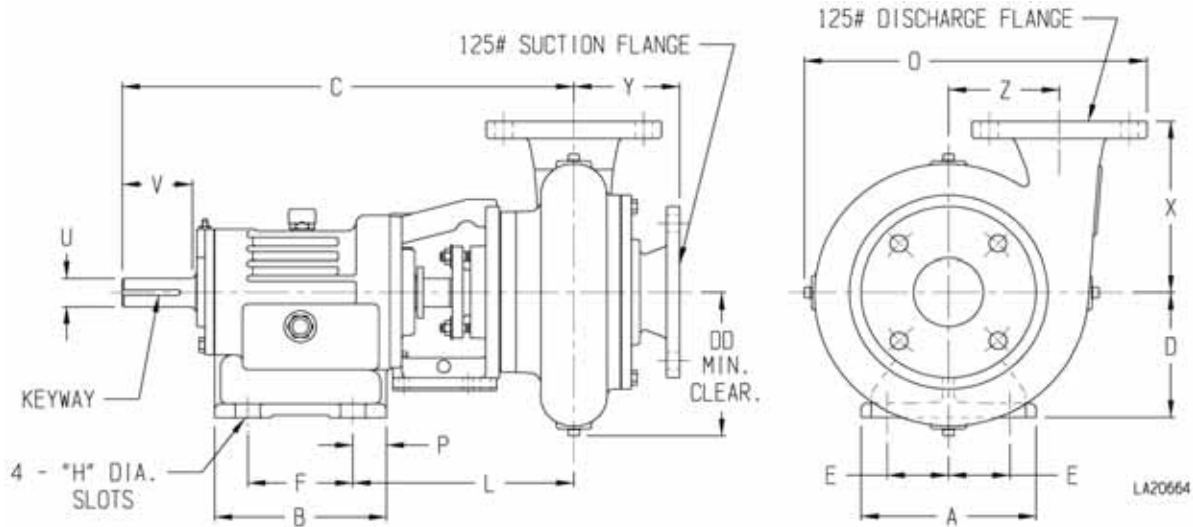

Notes:

1. Dimension "Q" is maximum adjustment for field weld.
2. "V" dimension is maximum useable shaft.
3. Frame mounting foot thickness is .62".
4. Dimension "DD", "M", "MA", and "R" shown are for top vertical position only.
5. Flange connection dimension can vary $\pm .12$ inch.
6. Do not use for construction unless certified.

Notes:

1. Discharge positions viewed from the drive end.
2. Consult factory for other discharge positions.

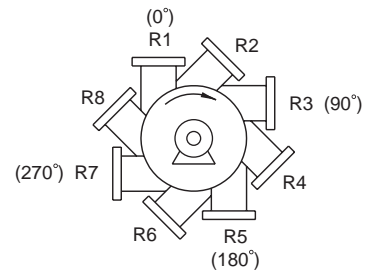

PUMP DIMENSIONS

Model	Frame	Connection		A	B	C	D	DD	E	F	H	L	M	MA	MB
		Disch.	Suct.												
3NLP	F5	3	3	7.5	7.36	23.69	5.5	11	2.62	4.5	0.56	13.75	25.78	11.28	11.5

PUMP DIMENSIONS (continued)

N	O	P	Q	R	S	U	V	W	X	Y	Z	KEYWAY
1.25	21.62	1.38	1.75	16.75	2.5	1.25	3	8	11	1.56	6.25	.25 X .12

Cornell Pump Company



CERTIFIED TO ISO 9001:2000