

## Flygt 4460



# Table of Contents

<b>1 Introduction.....</b>	<b>2</b>
1.1 Specially approved products.....	2
<b>2 Product Description.....</b>	<b>3</b>
2.1 The data plate.....	3
2.2 Approvals.....	4
2.3 Product denomination.....	5
<b>3 Exploded View.....</b>	<b>6</b>
3.1 Drive unit.....	6
3.2 Hydraulic unit.....	7
3.3 Installation components.....	8
<b>4 List of Parts.....</b>	<b>11</b>
4.1 4460.010/020/090.....	11

# 1 Introduction

## Purpose of this manual

The purpose of this manual is to provide necessary information on spare parts and accessories order.

## Disclaimer

Always use genuine Flygt parts. The use of other spare parts or accessories can invalidate any claims for warranty or compensation. Xylem does not take any responsibility for damages that are caused by the use of non-original parts. For more information, contact your local sales and service representative.

## Data for ordering spare parts

The following information is needed for spare part orders:

- Serial number of the product
- Part number
- Quantity of bulk material, see \* in tables

## 1.1 Specially approved products

### Qualification of personnel

Only Xylem or Xylem-authorized service personnel may undertake repair work on specially approved products.

### Dimensional accuracy inspection

Spare parts marked with (Ex) after the part number are subject to dimensional accuracy inspection when used in specially approved products.

# 2 Product Description

## 2.1 The data plate

The data plate is a metal label that is located on the main body of the products. The data plate lists key product specifications. Specially approved products also have an approval plate.

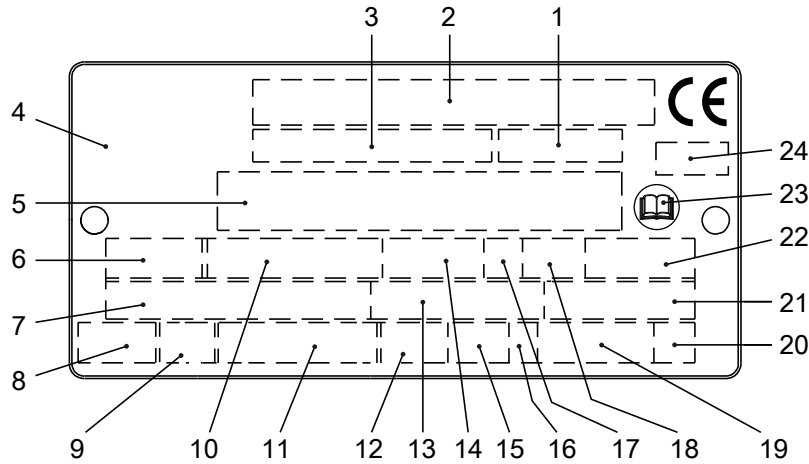

WIS006257A

1. Curve code or Propeller code
2. Serial number
3. Product number
4. Country of origin
5. Additional information
6. Phase; type of current; frequency
7. Rated voltage
8. Thermal protection
9. Thermal class
10. Rated shaft power
11. International standard
12. Degree of protection
13. Rated current
14. Rated speed
15. Maximum submergence
16. Direction of rotation: L=left, R=right
17. Duty class
18. Duty factor
19. Product weight
20. Locked rotor code letter
21. Power factor
22. Maximum ambient temperature
23. Read installation manual
24. Notified body, only for EN-approved Ex products

Figure 1: The data plate

## 2.2 Approvals

Product approvals for hazardous locations

Product	Approval
4460.090	European Norm (EN) <ul style="list-style-type: none"> <li>• ATEX Directive</li> <li>• EN 60079-0:2012/A11:2013, EN 60079-1:2007, EN 13463-1:2009, EN 13463-5:2011</li> <li>•  II 2 G c Ex d IIB T4 Gb</li> </ul>
	IEC <ul style="list-style-type: none"> <li>• IECEx scheme</li> <li>• IEC 60079-0, IEC 60079-1</li> <li>• Ex d IIB T4 Gb</li> </ul>
	FM (FM Approvals) <ul style="list-style-type: none"> <li>• Explosion proof for use in Class I, Div. 1, Group C and D</li> <li>• Dust ignition proof for use in Class II, Div. 1, Group E, F and G</li> <li>• Suitable for use in Class III, Div. 1, Hazardous Locations</li> </ul>

### EN approval plate

This illustration describes the EN approval plate and the information that is contained in its fields.

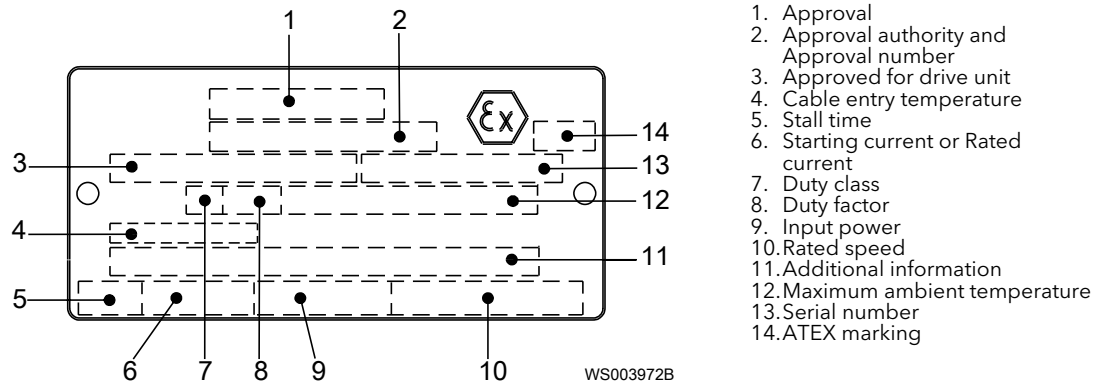

### IEC approval plate

This illustration describes the IEC approval plate and the information that is contained in its fields.

International Norm; not for EU member countries.

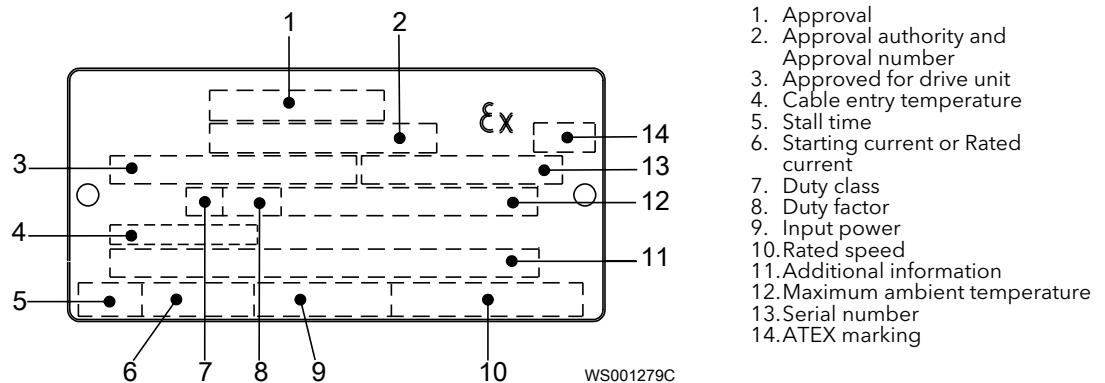

FM approval plate

This illustration describes the FM approval plate and the information that is contained in its fields.

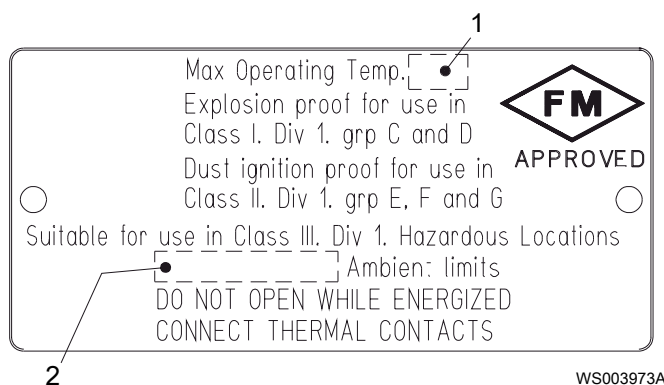

- 1. Temperature class
- 2. Maximum ambient temperature

2.3 Product denomination

Reading instruction

In this section, code characters are illustrated accordingly:

X = letter

Y = digit

The different types of codes are marked up with a, b and c. Code parameters are marked up with numbers.

Codes and parameters

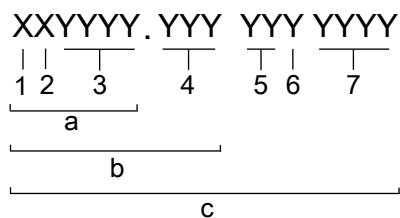

WS006265B

Type of Callout	Number	Indication
Type of code	a	Sales denomination
	b	Product code
	c	Serial number
Parameter	1	Hydraulic end
	2	Type of installation
	3	Sales code
	4	Version
	5	Production year
	6	Production cycle
	7	Running number

# 3 Exploded View

## 3.1 Drive unit

4460

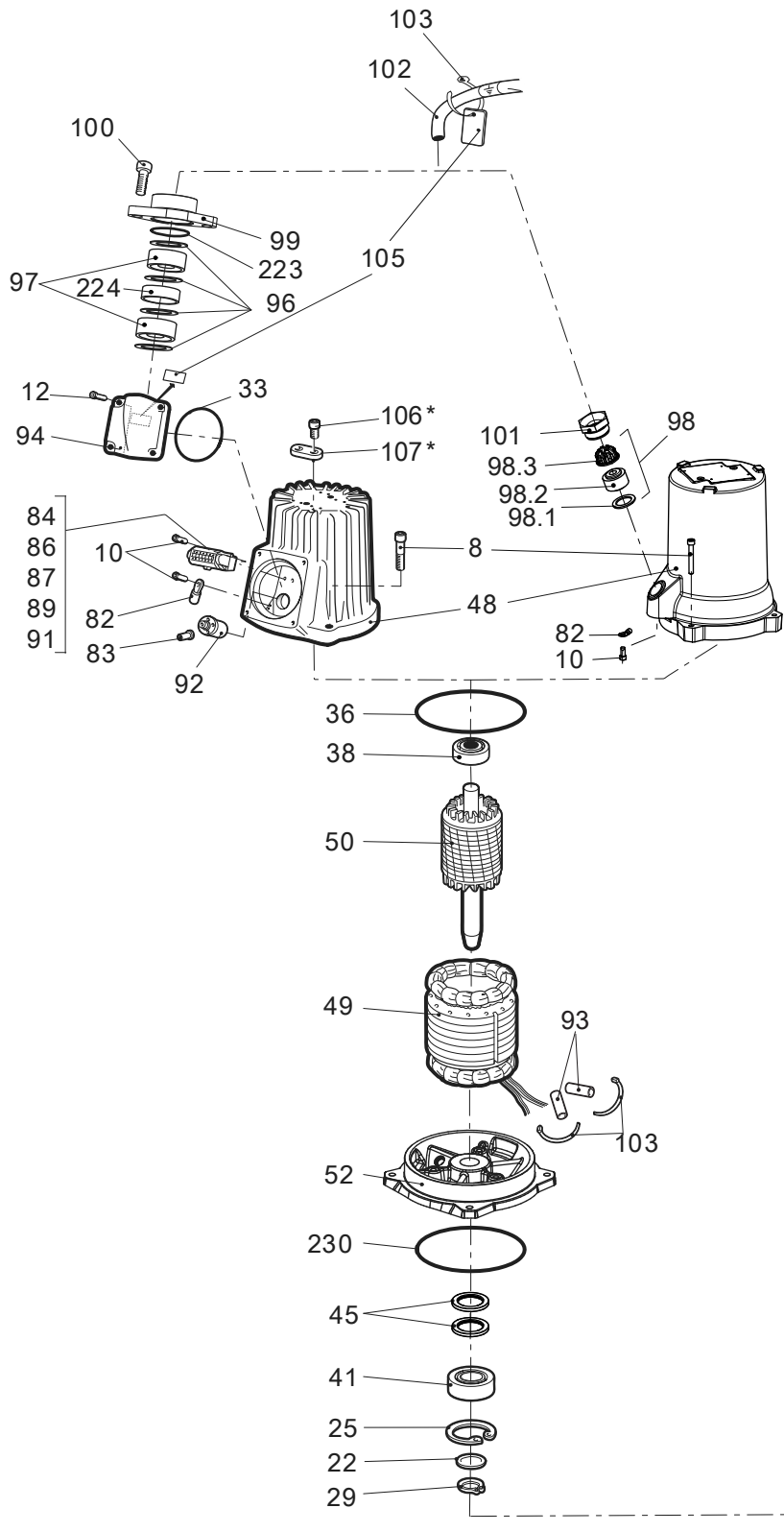

4090 00

### 3.2 Hydraulic unit

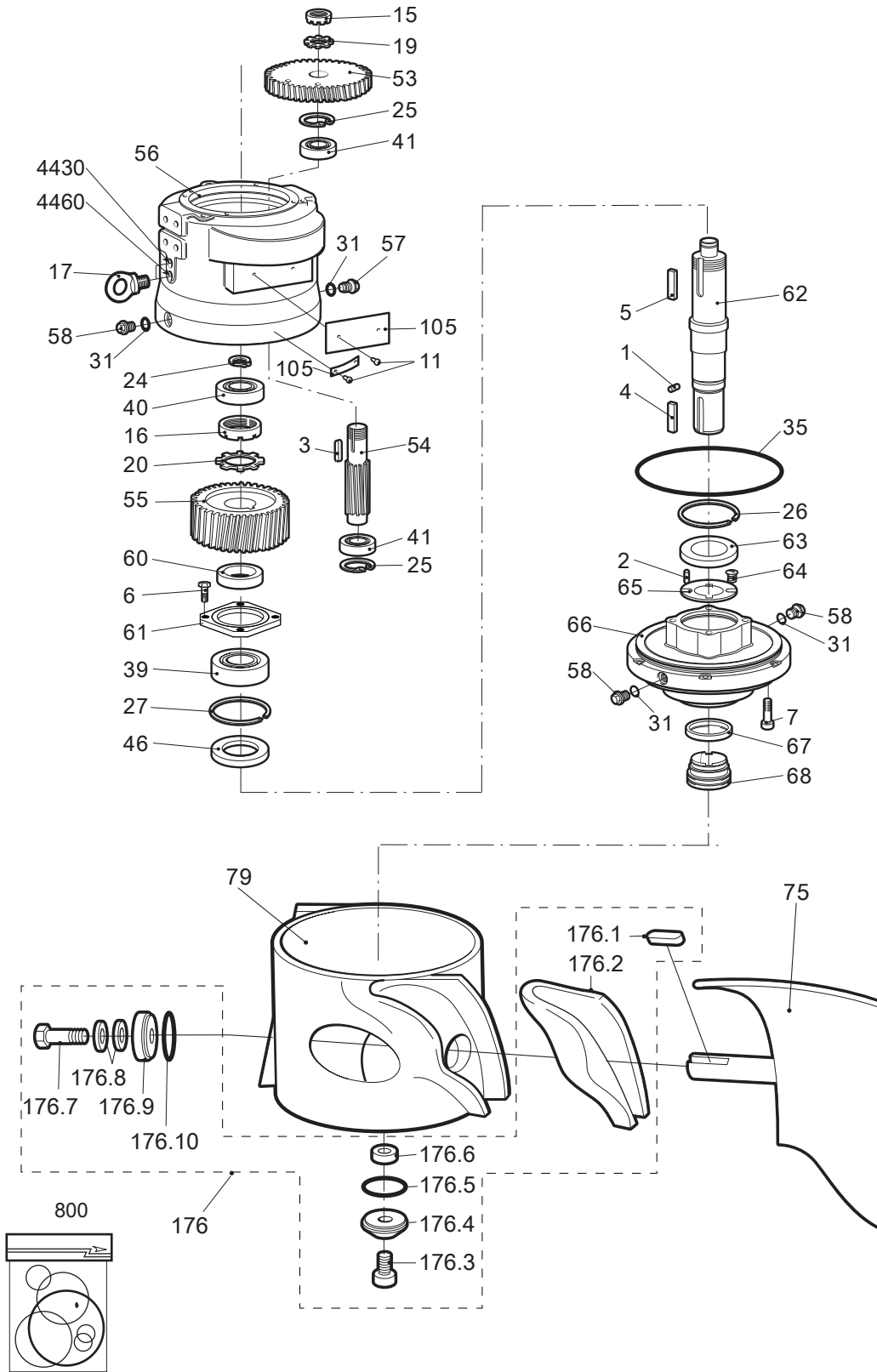

4079 1D



### 3.3 Installation components

4410 /4430 /4460 /4530

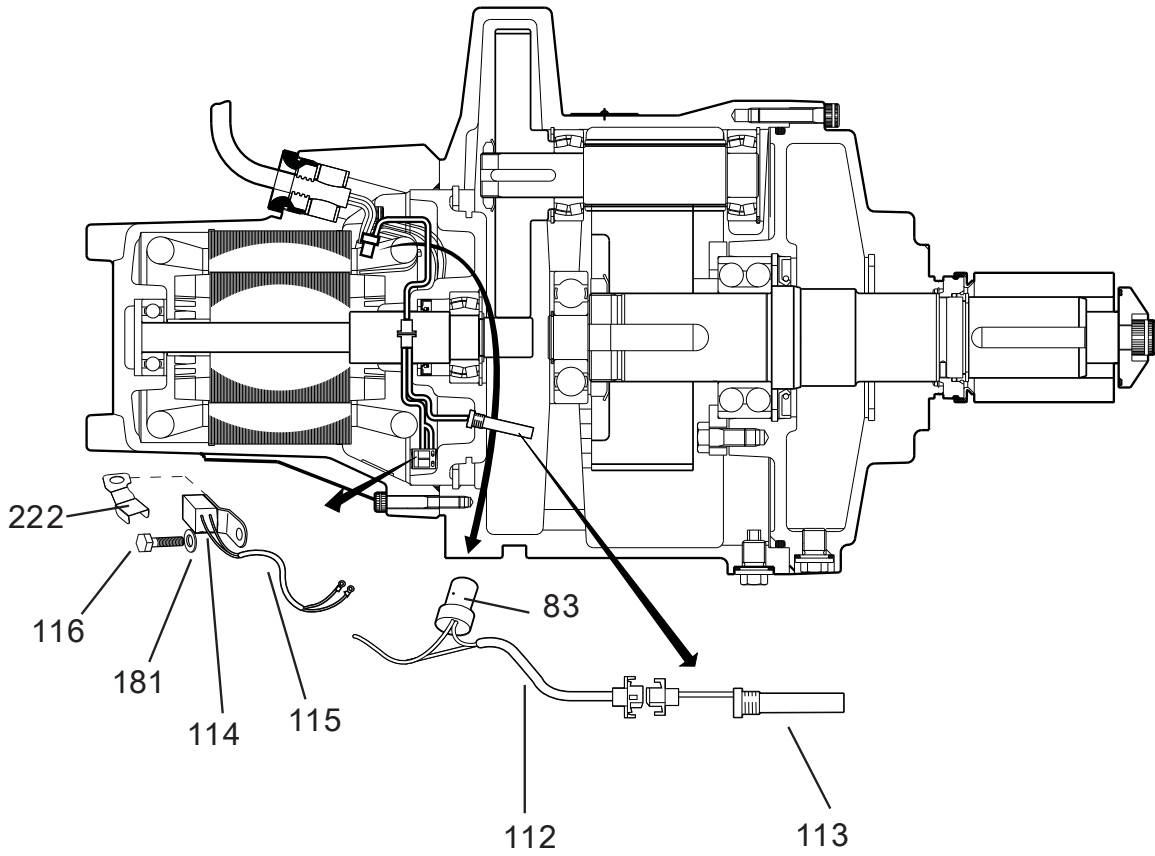

40822E

Figure 2: Leakage sensors

4410 / 4430 / 4460

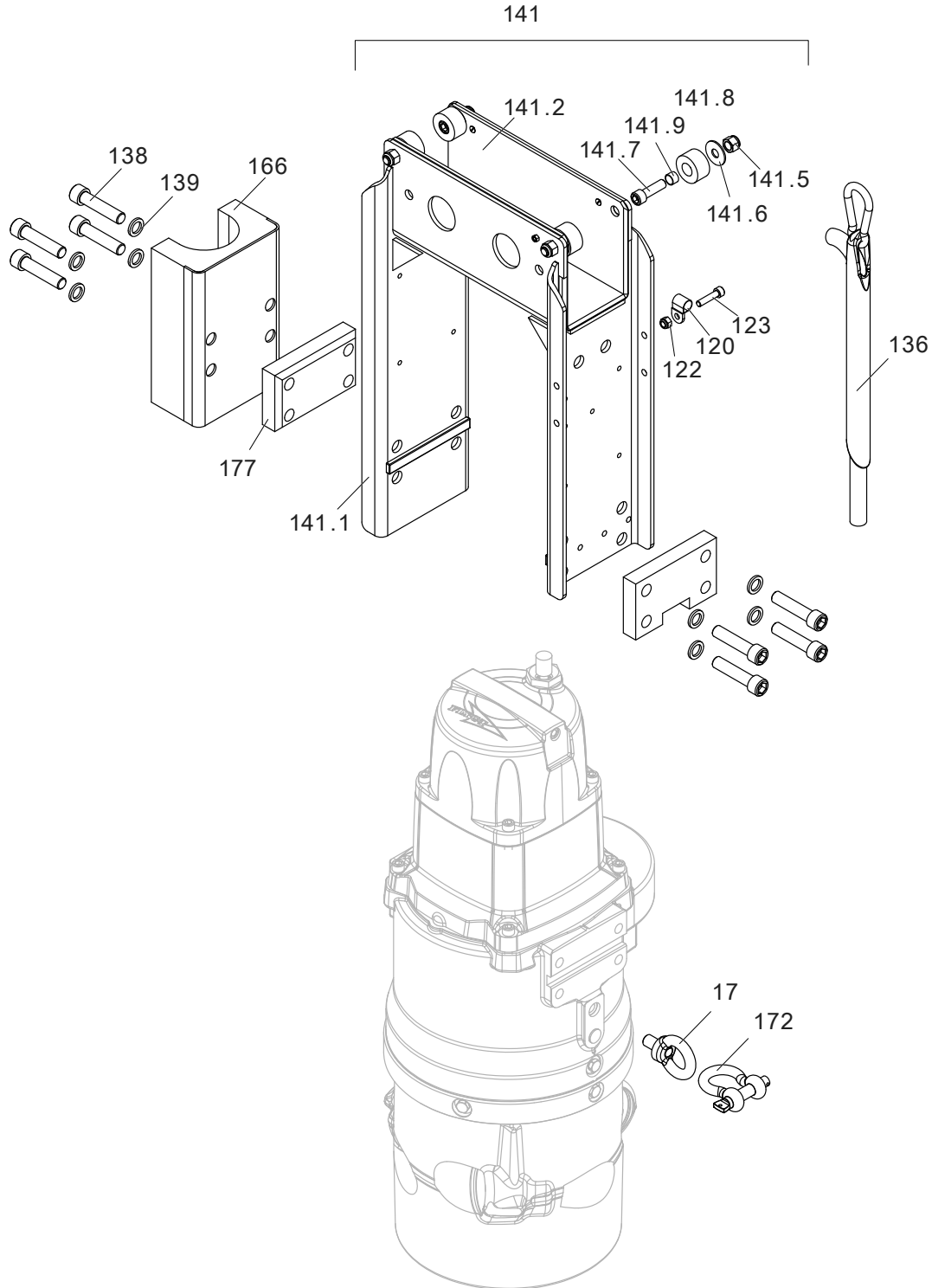

Figure 3: Tripod guide bar

4060 8G

4410 /4430 /4460

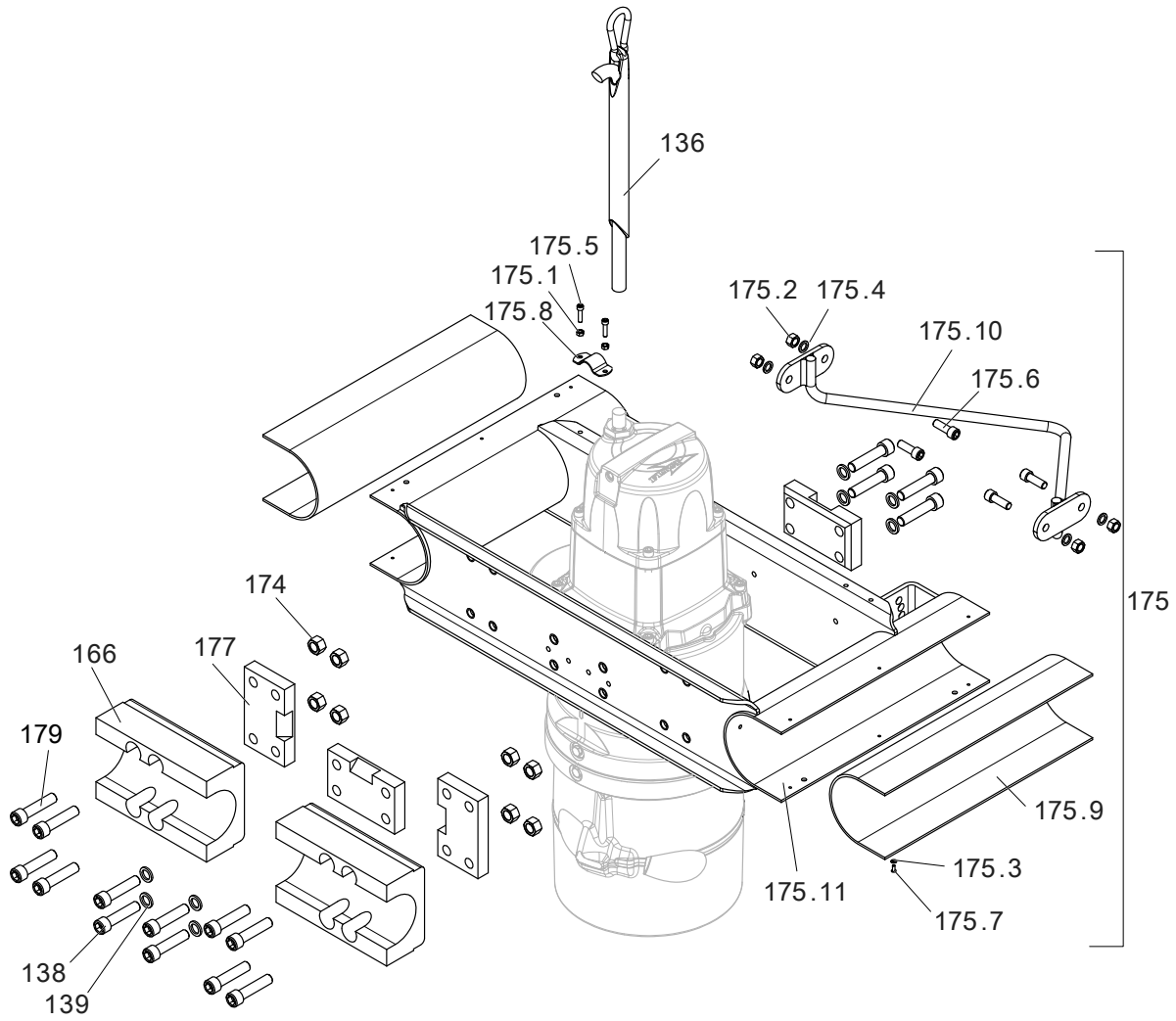

Figure 4: Double guide bar

40614E

# 4 List of Parts

## 4.1 4460.010/020/090

Pos. No	Part. No	Type	Denomination	Qty/Version		
				010	020	090
1	80 23 05		Parallel pin CP-H8-4X10-1650	1	1	1
2	80 57 71		Tension pin	2	2	2
3	80 70 62		Parallel key 8H9X7H11X40	1	1	1
4	80 46 27		Parallel key 14H9X9H11X70	1	1	1
5	80 46 31		Parallel key 18H9X11H11X56	1	1	1
6	81 41 54		Hexagon head screw M12X25-A2-70	4	4	4
7	83 03 27		Hex.socket hd screw M10X45-A4-70	6	6	6
8	83 02 65		Hex.socket hd screw M10X65-A4-70	4	4	4
10	82 17 61		Cutting screw TAPTITE-M6X12	3	1	3
10	82 17 61		Cutting screw TAPTITE-M6X12	1		1
10	82 17 61		Cutting screw TAPTITE-M6X12		1	
11	82 20 88		Drive screw 4X5-A2/A4	6	6	10
12	83 04 45		Hex.socket hd screw M8X35-A4-80	4		4
15	82 22 31		Round nut M30X1.5	1	1	1
16	82 22 37		Round nut M60X2	1	1	1
17	82 31 15		Lifting eye bolt	1	1	1
17	82 70 92		Protective plug	2	2	4
17	84 35 20		Protective plug	2		2
17	84 35 21		Protective plug		3	
19	82 51 31		Lock washer	1	1	1
20	82 51 37		Lock washer	1	1	1
22	82 44 09		Supporting washer 25X35X2	1		1
22	82 44 11		Supporting washer 28X40X2	1	1	1
24	82 59 06		Retaining ring SGA 40	1	1	1
25	82 62 12		Retaining ring SGH 62	3	3	3
26	82 62 30		Retaining ring SGH 105	1	1	1
27	82 62 32		Retaining ring SGH 110	1	1	1
29	82 58 95		Retaining ring SGA 24	1		1
29	82 58 97		Retaining ring SGA 26	1	1	1
31	82 73 90		O-ring 19.2X3 NBR	5	5	5
33	82 74 79		O-ring 129.5X3 NBR	1		1
35	82 75 00		O-ring 269.3X5.7 NBR	1	1	1
36	82 74 97		O-ring 239.5X5.7 NBR	1	1	1
38	83 32 36		Ball bearing 6207,35X72X17	1	1	1
39	83 35 23		Roller bearing 60X110X28	1	1	1
40	84 53 76		Roller bearing ECP(40X90X23)	1	1	1
41	83 35 72		Roller bearing 22206 CC 30X62X20	3	3	3
45	82 85 69		Seal ring	2	2	2
46	82 85 52		Seal ring 70X110X8 NITRIL	1	1	1

Pos. No	Part. No	Type	Denomination	Qty/Version			
				010	020	090	
48	443 53 04	(Ex)	Stator housing	1			
48	722 70 02		Stator housing		1		
48	443 53 05		Stator housing			1	
49	309 44 12		Stator 21-12-4a	3-phase 60 Hz 4-poles 440V-460V YSER 220V-230V Y// P2=6,30kW/ 8,40hp	1		1
49	309 44 30		Stator 21-12-4a	60 Hz 4-poles 380V D P2=6,30kW/ 8,40hp	1		1
49	309 44 34		Stator 21-12-4a	50 Hz 4-poles 380V-400V Y 220V-230V D P2=5,70kW 60 Hz 4-poles 440V-460V Y 260V D P2=6,30kW/8,40hp	1		1
49	309 44 38		Stator 21-12-4a	50 Hz 4-poles 660V-690V Y 380V-400V D P2=5,70kW 60 Hz 4-poles 440V-460V D P2=6,30kW/8,40hp	1		1
49	309 44 44		Stator 21-12-4a	50 Hz 4-poles 400V-440V D P2=5,70kW	1		1
49	309 44 50		Stator 21-12-4a	50 Hz 4-poles 500V D P2=5,70kW 60 Hz 4-poles 575V D P2=6,30kW/ 8,40hp	1		1
49	309 49 01		Stator 21-11-2a	50 Hz 2-poles 400V Y 230V D P2=7,50kW 60 Hz 2-poles 480V Y P1=9,80KW Max ambient temperature 60 DC 50 Hz 2-poles 230V D 400V Y P1=8,90KW Max ambient temperature 60 DC 60 Hz 2-poles 480V Y P2=8,20kW/ 11hp	1		1
49	309 49 30		Stator 21-11-2a	60 Hz 2-poles 380V D 660V Y P1=9,70KW Max ambient temperature 60 DC 60 Hz 2-poles 660V Y 380V D P2=8,20kW/11hp	1		1
49	309 49 34		Stator 21-11-2a	50 Hz 2-poles 380V Y 220V D P2=7,50kW 60 Hz 2-poles 260V D 440V-460V Y P1=9,70KW Max ambient temperature 60 DC 50 Hz 2-poles 220V D 380V Y P1=8,90KW Max ambient temperature 60 DC 60 Hz 2-poles 440V-460V Y 260V D P2=8,20kW/11hp	1		1

Pos. No	Part. No	Type	Denomination	Qty/Version		
				010	020	090
49	309 49 38		Stator 21-11-2a 50 Hz 2-poles 660V Y 380V D P2=7,50kW 60 Hz 2-poles 440V-460V D P1=9,70KW Max ambient temperature 60 DC 50 Hz 2-poles 380V D 660V Y P1=8,90KW Max ambient temperature 60 DC 60 Hz 2-poles 440V-460V D P2=8,20kW/11hp	1		1
49	309 49 44		Stator 21-11-2a 50 Hz 2-poles 400V-440V D P2=7,50kW 50 Hz 2-poles 400V-440V D Max P1=9KW Max ambient temperature 60 DC	1		1
49	309 49 50		Stator 21-11-2a 50 Hz 2-poles 500V D P2=7,50kW 60 Hz 2-poles 575V D P1=9,70KW Max ambient temperature 60 DC 50 Hz 2-poles 500V D P1=8,90KW Max ambient temperature 60 DC 60 Hz 2-poles 575V D P2=8,20kW/ 11hp	1		1
49	661 39 01		Stator 21-18-2b 50 Hz 2-poles 400V-440V D P2=12kW Max ambient temp=40 DC 140 DC 60 Hz 2-poles 460V-480V D P1=15,30KW Max ambient temperature 60 DC 140 DC 50 Hz 2-poles 400V-440V D Max P1=13,30KW Max ambient temp=60 DC 140 DC 60 Hz 2-poles 460V-480V D P2=14kW/18,80hp 140 DC		1	
50	680 19 00		Shaft unit Reduction ratio: 36,69:1 Frequency: 50 Hz Number of Poles: 4 Propeller Speed: 41 rpm Reduction ratio: 36,69:1 Frequency: 60 Hz Number of Poles: 4 Propeller Speed: 49 rpm Reduction ratio: 40,81:1 Frequency: 50 Hz Number of Poles: 4 Propeller Speed: 36 rpm Reduction ratio: 40,81:1 Frequency: 60 Hz Number of Poles: 4 Propeller Speed: 44 rpm	1		

Pos. No	Part. No	Type	Denomination	Qty/Version		
				010	020	090
50	680 19 01		Shaft unit Reduction ratio: 31,04:1 Frequency: 50 Hz Number of Poles: 4 Propeller Speed: 47 rpm Reduction ratio: 31,04:1 Frequency: 60 Hz Number of Poles: 4 Propeller Speed: 57 rpm Reduction ratio: 34,80:1 Frequency: 50 Hz Number of Poles: 4 Propeller Speed: 42 rpm Reduction ratio: 34,80:1 Frequency: 60 Hz Number of Poles: 4 Propeller Speed: 51 rpm	1		
50	680 19 07		Shaft unit Reduction ratio: 42:1 Frequency: 50 Hz Number of Poles: 2 Propeller Speed: 69 rpm Reduction ratio: 42:1 Frequency: 50 Hz Number of Poles: 2 Propeller Speed: 69 rpm	1		
50	680 19 06		Shaft unit Reduction ratio: 49,23:1 Frequency: 60 Hz Number of Poles: 2 Propeller Speed: 72 rpm Reduction ratio: 49,23:1 Frequency: 60 Hz Number of Poles: 2 Propeller Speed: 72 rpm	1		
50	680 19 05		Shaft unit Reduction ratio: 44,96:1 Frequency: 60 Hz Number of Poles: 2 Propeller Speed: 79 rpm Reduction ratio: 44,96:1 Frequency: 60 Hz Number of Poles: 2 Propeller Speed: 79 rpm Reduction ratio: 36,96:1 Frequency: 50 Hz Number of Poles: 2 Propeller Speed: 80 rpm Reduction ratio: 36,96:1 Frequency: 50 Hz Number of Poles: 2 Propeller Speed: 80 rpm		1	
50	680 19 10	(Ex)	Shaft unit Reduction ratio: 36,69:1 Frequency: 50 Hz Number of Poles: 4 Propeller Speed: 41 rpm Reduction ratio: 36,69:1 Frequency: 60 Hz Number of Poles: 4 Propeller Speed: 49 rpm Reduction ratio: 40,81:1 Frequency: 50 Hz Number of Poles: 4 Propeller Speed: 36 rpm Reduction ratio: 40,81:1 Frequency: 60 Hz Number of Poles: 4 Propeller Speed: 44 rpm			1

Pos. No	Part. No	Type	Denomination	Qty/Version		
				010	020	090
50	680 19 11	(Ex)	Shaft unit Reduction ratio: 31,04:1 Frequency: 50 Hz Number of Poles: 4 Propeller Speed: 47 rpm Reduction ratio: 31,04:1 Frequency: 60 Hz Number of Poles: 4 Propeller Speed: 57 rpm Reduction ratio: 34,80:1 Frequency: 50 Hz Number of Poles: 4 Propeller Speed: 42 rpm Reduction ratio: 34,80:1 Frequency: 60 Hz Number of Poles: 4 Propeller Speed: 51 rpm			1
50	680 19 17	(Ex)	Shaft unit Reduction ratio: 42:1 Frequency: 50 Hz Number of Poles: 2 Propeller Speed: 69 rpm Reduction ratio: 42:1 Frequency: 50 Hz Number of Poles: 2 Propeller Speed: 69 rpm			1
50	680 19 16	(Ex)	Shaft unit Reduction ratio: 49,23:1 Frequency: 60 Hz Number of Poles: 2 Propeller Speed: 72 rpm Reduction ratio: 49,23:1 Frequency: 60 Hz Number of Poles: 2 Propeller Speed: 72 rpm			1
52	604 88 00		Bearing holder Leakage detector in the stator house: FLS	1	1	
52	604 88 02		Bearing holder Leakage detector in the stator house: FLS Water in oil supervision: CLS	1		
52	604 88 01	(Ex)	Bearing holder Leakage detector in the stator house :FLS			1
53	690 86 00		Gear Reduction ratio: 36,69:1 Frequency: 50 Hz Number of Poles: 4 Propeller Speed: 41 rpm Reduction ratio: 36,69:1 Frequency: 60 Hz Number of Poles: 4 Propeller Speed: 49 rpm Reduction ratio: 49,23:1 Frequency: 60 Hz Number of Poles: 2 Propeller Speed: 72 rpm Reduction ratio: 49,23:1 Frequency: 60 Hz Number of Poles: 2 Propeller Speed: 72 rpm Reduction ratio: 40,81:1 Frequency: 50 Hz Number of Poles: 4 Propeller Speed: 36 rpm Reduction ratio: 40,81:1 Frequency: 60 Hz Number of Poles: 4 Propeller Speed: 44 rpm	1		1



Pos. No	Part. No	Type	Denomination	Qty/Version		
				010	020	090
53	690 86 01		Gear Reduction ratio: 42:1 Frequency: 50 Hz Number of Poles: 2 Propeller Speed: 69 rpm Reduction ratio: 31,04:1 Frequency: 50 Hz Number of Poles: 4 Propeller Speed: 47 rpm Reduction ratio: 31,04:1 Frequency: 60 Hz Number of Poles: 4 Propeller Speed: 57 rpm Reduction ratio: 42:1 Frequency: 50 Hz Number of Poles: 2 Propeller Speed: 69 rpm Reduction ratio: 34,80:1 Frequency: 50 Hz Number of Poles: 4 Propeller Speed: 42 rpm Reduction ratio: 34,80:1 Frequency: 60 Hz Number of Poles: 4 Propeller Speed: 51 rpm	1		1
53	690 86 01		Gear Reduction ratio: 42:1 Frequency: 50 Hz Number of Poles: 2 Propeller Speed: 69 rpm Reduction ratio: 31,04:1 Frequency: 50 Hz Number of Poles: 4 Propeller Speed: 47 rpm Reduction ratio: 31,04:1 Frequency: 60 Hz Number of Poles: 4 Propeller Speed: 57 rpm Reduction ratio: 42:1 Frequency: 50 Hz Number of Poles: 2 Propeller Speed: 69 rpm Reduction ratio: 34,80:1 Frequency: 50 Hz Number of Poles: 4 Propeller Speed: 42 rpm Reduction ratio: 34,80:1 Frequency: 60 Hz Number of Poles: 4 Propeller Speed: 51 rpm	1	1	1
53	690 86 01		Gear Reduction ratio: 42:1 Frequency: 50 Hz Number of Poles: 2 Propeller Speed: 69 rpm Reduction ratio: 31,04:1 Frequency: 50 Hz Number of Poles: 4 Propeller Speed: 47 rpm Reduction ratio: 31,04:1 Frequency: 60 Hz Number of Poles: 4 Propeller Speed: 57 rpm Reduction ratio: 42:1 Frequency: 50 Hz Number of Poles: 2 Propeller Speed: 69 rpm Reduction ratio: 34,80:1 Frequency: 50 Hz Number of Poles: 4 Propeller Speed: 42 rpm Reduction ratio: 34,80:1 Frequency: 60 Hz Number of Poles: 4 Propeller Speed: 51 rpm		1	

Pos. No	Part. No	Type	Denomination	Qty/Version		
				010	020	090
54	464 48 01		Shaft Reduction ratio: 36,69:1 Frequency: 50 Hz Number of Poles: 4 Propeller Speed: 41 rpm Reduction ratio: 36,69:1 Frequency: 60 Hz Number of Poles: 4 Propeller Speed: 49 rpm Reduction ratio: 31,04:1 Frequency: 50 Hz Number of Poles: 4 Propeller Speed: 47 rpm Reduction ratio: 31,04:1 Frequency: 60 Hz Number of Poles: 4 Propeller Speed: 57 rpm	1		1
54	464 48 02		Shaft Reduction ratio: 34,80:1 Frequency: 50 Hz Number of Poles: 4 Propeller Speed: 42 rpm Reduction ratio: 34,80:1 Frequency: 60 Hz Number of Poles: 4 Propeller Speed: 51 rpm Reduction ratio: 40,81:1 Frequency: 50 Hz Number of Poles: 4 Propeller Speed: 36 rpm Reduction ratio: 40,81:1 Frequency: 60 Hz Number of Poles: 4 Propeller Speed: 44 rpm	1		1
54	464 48 04		Shaft Reduction ratio: 42:1 Frequency: 50 Hz Number of Poles: 2 Propeller Speed: 69 rpm Reduction ratio: 42:1 Frequency: 50 Hz Number of Poles: 2 Propeller Speed: 69 rpm Reduction ratio: 49,23:1 Frequency: 60 Hz Number of Poles: 2 Propeller Speed: 72 rpm Reduction ratio: 49,23:1 Frequency: 60 Hz Number of Poles: 2 Propeller Speed: 72 rpm	1		1
54	464 48 06		Shaft Reduction ratio: 36,96:1 Frequency: 50 Hz Number of Poles: 2 Propeller Speed: 80 rpm Reduction ratio: 36,96:1 Frequency: 50 Hz Number of Poles: 2 Propeller Speed: 80 rpm		1	
54	464 48 00		Shaft Reduction ratio: 44,96:1 Frequency: 60 Hz Number of Poles: 2 Propeller Speed: 79 rpm Reduction ratio: 44,96:1 Frequency: 60 Hz Number of Poles: 2 Propeller Speed: 79 rpm		1	

Pos. No	Part. No	Type	Denomination	Qty/Version		
				010	020	090
55	464 49 01		Gear Reduction ratio: 36,69:1 Frequency: 50 Hz Number of Poles: 4 Propeller Speed: 41 rpm Reduction ratio: 36,69:1 Frequency: 60 Hz Number of Poles: 4 Propeller Speed: 49 rpm Reduction ratio: 31,04:1 Frequency: 50 Hz Number of Poles: 4 Propeller Speed: 47 rpm Reduction ratio: 31,04:1 Frequency: 60 Hz Number of Poles: 4 Propeller Speed: 57 rpm	1		1
55	464 49 02		Gear Reduction ratio: 34,80:1 Frequency: 50 Hz Number of Poles: 4 Propeller Speed: 42 rpm Reduction ratio: 34,80:1 Frequency: 60 Hz Number of Poles: 4 Propeller Speed: 51 rpm Reduction ratio: 40,81:1 Frequency: 50 Hz Number of Poles: 4 Propeller Speed: 36 rpm Reduction ratio: 40,81:1 Frequency: 60 Hz Number of Poles: 4 Propeller Speed: 44 rpm	1		1
55	464 49 04		Gear Reduction ratio: 42:1 Frequency: 50 Hz Number of Poles: 2 Propeller Speed: 69 rpm Reduction ratio: 42:1 Frequency: 50 Hz Number of Poles: 2 Propeller Speed: 69 rpm Reduction ratio: 49,23:1 Frequency: 60 Hz Number of Poles: 2 Propeller Speed: 72 rpm Reduction ratio: 49,23:1 Frequency: 60 Hz Number of Poles: 2 Propeller Speed: 72 rpm	1		1
55	464 49 06		Gear Reduction ratio: 36,96:1 Frequency: 50 Hz Number of Poles: 2 Propeller Speed: 80 rpm Reduction ratio: 36,96:1 Frequency: 50 Hz Number of Poles: 2 Propeller Speed: 80 rpm		1	
55	464 49 00		Gear Reduction ratio: 44,96:1 Frequency: 60 Hz Number of Poles: 2 Propeller Speed: 79 rpm Max ambient temperature: 60 DC Reduction ratio: 44,96:1 Frequency: 60 Hz Number of Poles: 2 Propeller Speed: 79 rpm		1	
56	464 51 06		Gear housing	1	1	1
57	416 94 00		Inspection screw	1	1	1
58	428 22 17		Inspection screw BRASS	4	4	4
60	464 61 01		Ring	1	1	1
61	775 80 01		Supporting washer	1	1	1

Pos. No	Part. No	Type	Denomination	Qty/Version		
				010	020	090
62	701 45 00		Shaft	1	1	1
63	493 97 00		Ring	1	1	1
64	456 71 00		Compression spring	12	12	12
65	464 59 00		Washer 63X104X1.5	1	1	1
66	496 04 00		Oil housing	1	1	1
67	382 83 00		Wear protection NBR-A2	1	1	1
68	384 03 10		Mechanical seal WCCR/WCCR FPM	1	1	
68,1	82 80 94		O-ring 2X5.7 FPM	1	1	
68	384 03 10		Mechanical seal WCCR/WCCR FPM			1
68,1	82 80 94		O-ring 2X5.7 FPM			1
75	549 09 00		Propeller blade OD: 2500mm	2		2
75	549 09 01		Propeller blade OD: 2200mm	2		2
75	549 09 02		Propeller blade OD: 2000mm	2		2
75	549 09 03		Propeller blade OD: 1800mm	2		2
75	549 09 04		Propeller blade OD: 1700mm	2		2
75	549 09 09		Propeller blade OD: 1300mm	3	3	3
79	777 90 01		Propeller hub Coating: Std Thickness = min 120 micrometer	1		1
79	777 90 02		Propeller hub Coating: Spec Thickness = 360 - 450 micrometer	1		1
79	777 90 03		Propeller hub Coating: MBBR Thickness = 450 - 550 micrometer	1		1
79	777 90 00		Propeller hub Coating: Primer	1		1
79	771 83 01		Propeller hub Coating: Std Thickness = min 120 micrometer	1	1	1
79	771 83 02		Propeller hub Coating: Spec Thickness = 360 - 450 micrometer	1	1	1
82	83 43 58		Cable lug UL/CSA 1.04-2.62 MM2 M6	1		1
82	83 42 96		Cable lug 2.5-6 MM2 M6	1	1	1
82	83 42 62		Closed-end splice 0.33-0.82 (AWG 22-18)	4		4
82	83 42 96		Cable lug 2.5-6 MM2 M6	1		1
82	83 43 62		Cable lug UL/CSA 0.50-1.65 MM2 M6	1		1
82	83 42 96		Cable lug 2.5-6 MM2 M6		1	
82	83 43 62		Cable lug UL/CSA 0.50-1.65 MM2 M6		1	
83	83 44 24		Closed-end splice 3-6 (AWG 12-10)	3		3
83	83 44 24		Closed-end splice 3-6 (AWG 12-10)	1		
83	83 44 23		Closed-end splice 4.0-9.0 (AWG 8)		4	
84	83 44 23		Closed-end splice 4.0-9.0 (AWG 8)	1		1
84	83 44 24		Closed-end splice 3-6 (AWG 12-10)	2		2
84	83 44 24		Closed-end splice 3-6 (AWG 12-10)		2	
84	83 42 62		Closed-end splice 0.33-0.82 (AWG 22-18)		4	

Pos. No	Part. No	Type	Denomination	Qty/Version		
				010	020	090
86	83 53 21		Terminal clamp SAK6/35 038056 EL-AUTOM	6		6
87	83 53 22		End plate APPA - 11796	1		1
89	83 53 31		End support 35X15	2		2
91	443 68 00		Rail 35X15	1		1
92	734 59 00		El.lead through unit 12X + 6X	1		1
94	443 50 00		Entrance cover	1		
94	443 50 03	(Ex)	Entrance cover			1
96	82 40 81		Plain washer 32.5X52X2-A2-70	4		4
96	82 40 82		Plain washer 34.5X52X2-A2-70	4		4
97	84 18 01		Seal sleeve (17)-20 MM NBR	2		2
97	84 18 02		Seal sleeve (20)-23 MM NBR	2		2
97	84 18 03		Seal sleeve (23)-26 MM NBR	2		2
98	638 27 05	(Ex)	Cable entry unit 20-(22)MM NBR		1	
99	642 17 00		Entrance flange (20)-32 MM	1		
99	642 17 01	(Ex)	Entrance flange (14)-32 MM			1
100	83 03 48		Hex.socket hd screw M12X40-A4-70	2		2
101	397 81 01	(Ex)	Gland screw Pr 37		1	
101	463 58 00	(Ex)	Gland screw Pr 37		1	
			Cable entry: (20) - 23mm			
			Cable entry: (20) - 23mm Thread : ISO G1			
102	94 20 59		Motor cable subcab 4G2.5+2X1.5	*		*
102	94 20 60		Motor cable subcab 4G4+2X1.5	*	*	*
102	94 20 82		Motor cable subcab 7G2.5+2X1.5	*		*
102	94 19 90		Motor cable subcab S3X2.5+3X2.5/3+S(4X0.5)	*		*
102	94 20 56		Motor cable subcab 4G6+2X1.5	*		*
102	94 19 91		Motor cable subcab S3X6+3X6/3+S(4X0.5)		*	
103	83 45 59		Cable tie 200X2.4 PA 6/6 -55+105	1	1	1
105	630 68 00		Data plate USE 6306801 AS SPARE PART	2	2	2
105	775 03 00		Connection plate	1	1	1
105	630 69 01	(Ex)	Certificate plate IECEX			2
105	630 69 00		Certificate plate EN			2
105	630 70 00		Certificate plate FM			2
106	83 02 58		Hex.socket hd screw M5X12-A4-70			2
107	279 29 00		Earthing plate			1
112	504 78 05		Cable unit	1		
112,1	83 42 42		Contact pin	2		
112,2	83 53 40		Terminal device	1		
112,3	94 14 20		Single conductor	*		
112,4	94 14 31		Single conductor	*		
113	505 12 00		Leakage sensor (CLS30)	1		
114	731 64 00		Leakage sensor	1		1
115	504 78 09		Cable unit (FLS)	1		1

Pos. No	Part. No	Type	Denomination	Qty/Version		
				010	020	090
116	81 41 52		Hexagon head screw M12X20-A2-70	1		1
116	81 41 52		Hexagon head screw M12X20-A2-70	2		
117	83 97 48		Leakage sensor	1		
120	84 66 55		Cable clamp RUBBER SEALING STRIP 15MM	1		1
120	84 60 65		Cable clamp RUBBER SEALING STRIP 19MM	1	1	1
120	84 60 64		Cable clamp RUBBER SEALING STRIP 17MM	1		1
120	84 64 38		Cable clamp	1		1
122	82 27 27		Lock nut M8-A4-70	1	1	1
123	83 04 45		Hex.socket hd screw M8X35-A4-80	1	1	1
136	482 01 01		Cable supp.grip unit	1	1	1
138	83 03 76		Hex.socket hd screw M16X70-A4-70	8	8	8
139	82 50 19		Lock washer M16	8	8	8
141	481 95 12		Stand unit Guided Guide bar dimension: 100 x 150mm Material: stainless steel (ASTM 316L) Four fixed sleeves	1		1
141,1	481 92 09		Stand	1		1
141,2	481 96 02		Claw	1		1
141,5	82 27 29		Lock nut M12-A4-70	4		4
141,6	82 42 36		Plain washer 12.5X35X2-A4-70	4		4
141,7	83 03 48		Hex.socket hd screw M12X40-A4-70	4		4
141,8	481 93 00		Sleeve	4		4
141,9	481 94 00		Sleeve	4		4
141	481 95 10		Stand unit Guided Guide bar dimension: 100 x 100mm Material: stainless steel (ASTM 316L) Four fixed sleeves	1		1
141,1	481 92 07		Stand	1		1
141,2	481 96 01		Claw	1		1
141,5	82 27 29		Lock nut M12-A4-70	4		4
141,6	82 42 36		Plain washer 12.5X35X2-A4-70	4		4
141,7	83 03 48		Hex.socket hd screw M12X40-A4-70	4		4
141,8	481 93 00		Sleeve	4		4
141,9	481 94 00		Sleeve	4		4
141	481 95 13		Stand unit Guided Guide bar dimension: 100 x 150mm Material: stainless steel (ASTM 316L) Four fixed sleeves		1	
141,1	481 92 09		Stand			
141,2	481 96 02		Claw		1	
141,5	82 27 29		Lock nut M12-A4-70		4	
141,6	82 42 36		Plain washer 12.5X35X2-A4-70		4	
141,7	83 03 48		Hex.socket hd screw M12X40-A4-70		4	
141,8	481 93 00		Sleeve		4	
141,9	481 94 00		Sleeve		4	
166	482 04 02		Support	1		1

Pos. No	Part. No	Type	Denomination	Qty/Version		
				010	020	090
166	482 04 02		Support	2		2
172	82 26 49		Shackle	1		1
174	82 27 30		Lock nut M16-A4-70	8		8
175	509 53 06		Stand unit	1		1
175,1	82 23 31		Hexagon nut M6-A4-70	2		2
175,2	82 23 35		Hexagon nut M12-A4-70	4		4
175,3	82 35 71		Plain washer 4.3X9X0.8-A4-170HV	12		12
175,4	82 50 17		Lock washer M12	8		8
175,5	83 02 79		Hex.socket hd screw M6X25-A4-70	2		2
175,6	83 03 47		Hex.socket hd screw M12X35-A4-70	4		4
175,7	84 24 58		Blind rivet	12		12
175,8	465 42 00		Cable clamp	1		1
175,9	509 45 00		Claw	2		2
175,10	547 84 02		Lifting handle	1		1
176	753 29 00		Mounting kit PROPELLER	1		1
176,1	80 46 27		Parallel key 14H9X9H11X70	2		2
176,2	791 13 00		Damper	2		2
176,3	83 03 76		Hex.socket hd screw M16X70-A4-70	1		1
176,4	384 61 00		Supporting washer	1		1
176,5	82 77 96		O-ring 57.5X3 NBR	1		1
176,6	84 35 33		Seal sleeve (16)-18 MM CR	1		1
176,7	81 49 32		Hexagon head screw M16X45-A4-70	2		2
176,8	82 50 19		Lock washer M16	2		2
176,9	494 78 01		Supporting washer	2		2
176,10	82 74 66		O-ring 64.5X3 NBR	2		2
176	753 29 01		Mounting kit	1	1	1
176,1	80 46 27		Parallel key 14H9X9H11X70	3	3	3
176,2	791 13 00		Damper	3	3	3
176,3	83 03 76		Hex.socket hd screw M16X70-A4-70	1	1	1
176,4	384 61 00		Supporting washer	1	1	1
176,5	82 77 96		O-ring 57.5X3 NBR	1	1	1
176,6	84 35 33		Seal sleeve (16)-18 MM CR	1	1	1
176,7	81 49 32		Hexagon head screw M16X45-A4-70	3	3	3
176,8	82 50 19		Lock washer M16	3	3	3
176,9	494 78 01		Supporting washer	3	3	3
176,10	82 74 66		O-ring 64.5X3 NBR	3	3	3
177	800 65 00		Distance block	2	2	2
177	800 65 00		Distance block	4		4
178	807 82 00		Clamp		2	
179	84 66 55		Cable clamp RUBBER SEALING STRIP 15MM	1		
179	83 03 76		Hex.socket hd screw M16X70-A4-70	8		8
179	83 03 48		Hex.socket hd screw M12X40-A4-70		2	
180	82 50 17		Lock washer M12		2	

Pos. No	Part. No	Type	Denomination	Qty/Version		
				010	020	090
181	82 50 17		Lock washer M12	1		1
181	82 50 17		Lock washer M12	2		
222	679 03 00		Holder	2		
223	82 74 63		O-ring 49.5X3 NBR	1		1
224	597 98 02		Sleeve	1		1
230	82 74 91		O-ring 189.3X5.7 NBR	1	1	1
250	726 11 00		Fastening kit	1		1
400	667 40 00		Sticker	2	2	2
800	82 97 19		O-ring kits	1	1	1
801	775 84 00		Basic repair kit	1	1	1
801	466 26 14		Zinc anode kit	1		1
801	466 26 15		Zinc anode kit	1		1
900	814 46 00		Mounting kit	1	1	1
901	90 17 52		Oil ISO VG 32	*	*	*
901	90 17 58		Oil GEAR UNITS	5	5	5
901	90 17 64		Oil	5	5	5
912	82 73 90		O-ring 19.2X3 NBR	5	5	5
915	659 35 00		Mounting kit MBBR	1		1