

CP 3102 MT 3~ 432

Technische specificaties

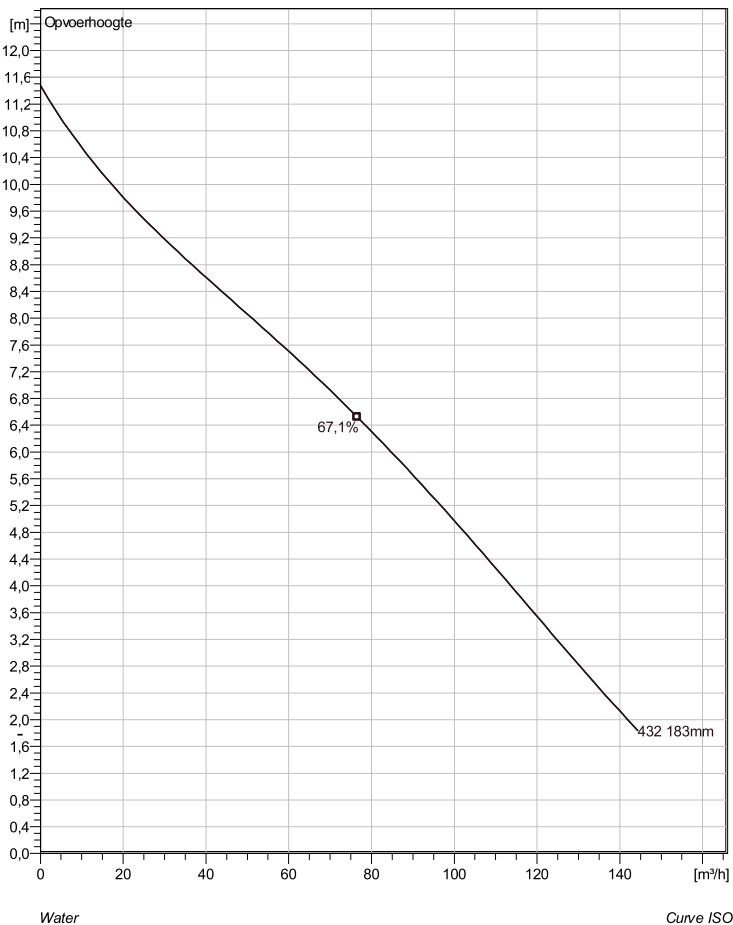

Note: Picture might not correspond to the current configuration.

General

Dompelbare pompen voorzien van één of meerkanaalwaaier met grote doorlaat. Geschikt voor afvalwater met grotere delen zoals rioolwater, regenwater en industrieel afvalwater. Materiaal gietijzer.

Impeller

Impeller material	Grey cast iron
Persaansluiting	100 mm
Diameter aanzuigzijde	100 mm
Impeller diameter	183 mm
Aantal bladen	1
Throughlet diameter	76 mm

Motor

Motor #	C3102.181 18-11-4AL-W 3.1KW standaard
Stator variant	66
Frequentie	50 Hz
Nominale spanning	190 V
Aantal polen	4
Fasen	3~
Nominaal vermogen	3,1 kW
Toegekende stroom	13 A
Aanloopstroom	71 A
Nominaal toerental	1440 rpm
Vermogensfactor	
1/1 Load	0,84
3/4 Load	0,79
1/2 Load	0,68
Motor efficiency	
1/1 Load	83,5 %
3/4 Load	85,0 %
1/2 Load	84,0 %

Soort installatie: Semi Permanent, Nat

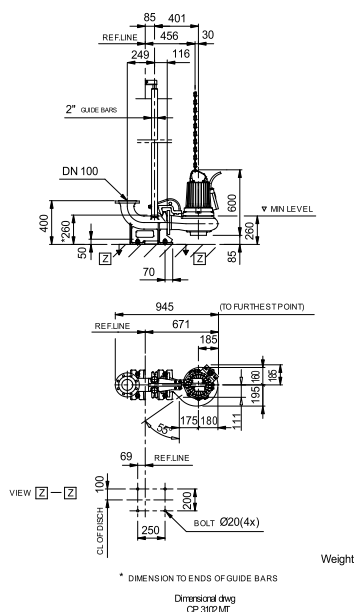

Project omschrijving	Projectnummer	Aangemaakt door:	Aangemaakt op 9/27/2018	Laatste wijziging
----------------------	---------------	------------------	----------------------------	-------------------

CP 3102 MT 3~ 432

Karakteristiek

Pomp

Persaansluiting	100 mm
Diameter aanzuigzijde	100 mm
Impeller diameter	183 mm
Aantal bladen	1
Throughlet diameter	76 mm

Motor

Motor #	C3102.181 18-11-4AL-W 3.1KW
Stator variant	66
Frequentie	50 Hz
Nominale spanning	190 V
Aantal polen	4
Fasen	3~
Nominaal vermogen	3,1 kW
Toegekende stroom	13 A
Aanloopstroom	71 A
Nominaal toerental	1440 rpm

Vermogensfactor	
1/1 Load	0,84
3/4 Load	0,79
1/2 Load	0,68
Motor efficiency	
1/1 Load	83,5 %
3/4 Load	85,0 %
1/2 Load	84,0 %

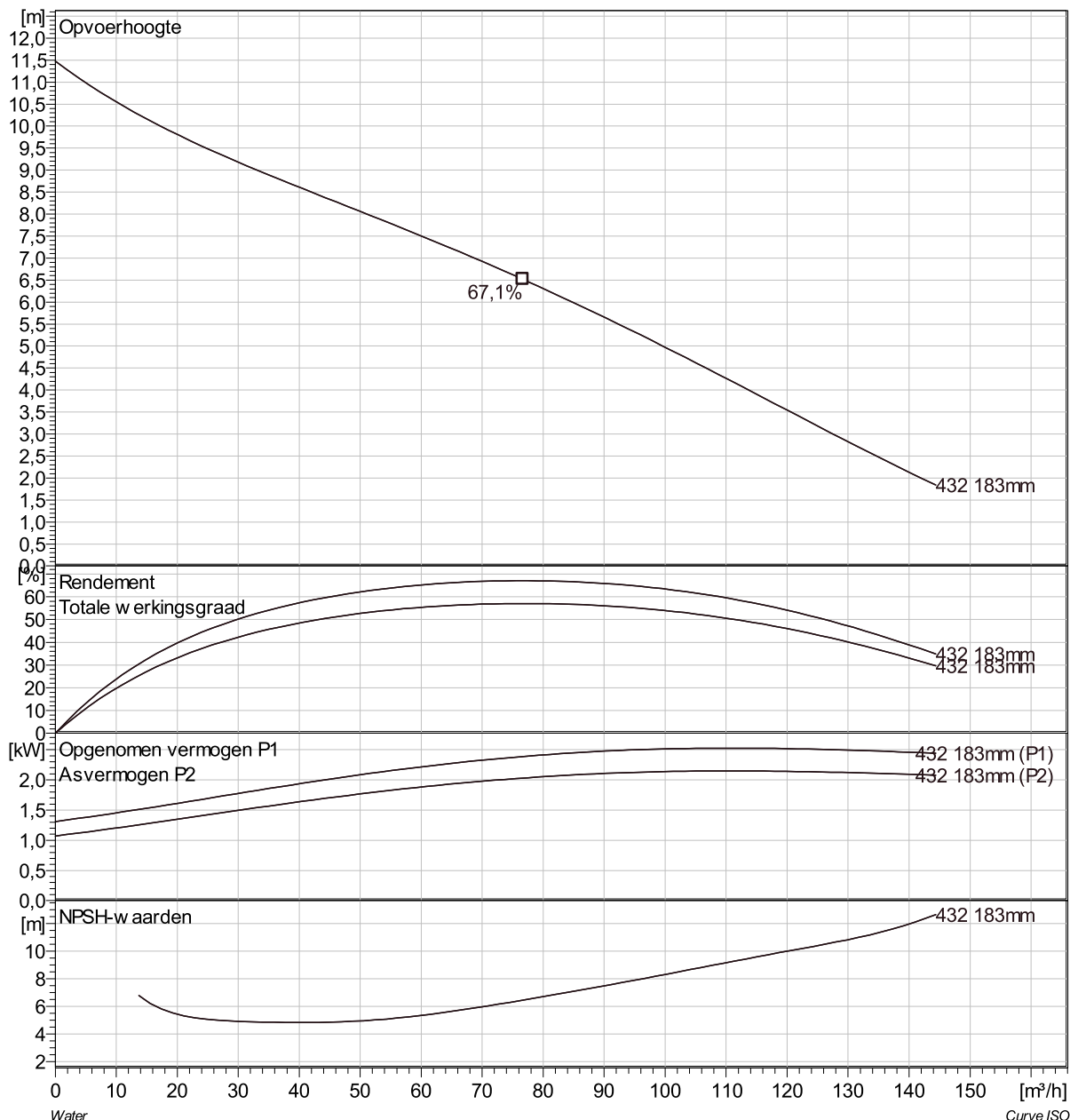

Project omschrijving	Projectnummer	Aangemaakt door:	Aangemaakt op 9/27/2018	Laatste wijziging
----------------------	---------------	------------------	----------------------------	-------------------

CP 3102 MT 3~ 432 VFD Analysis

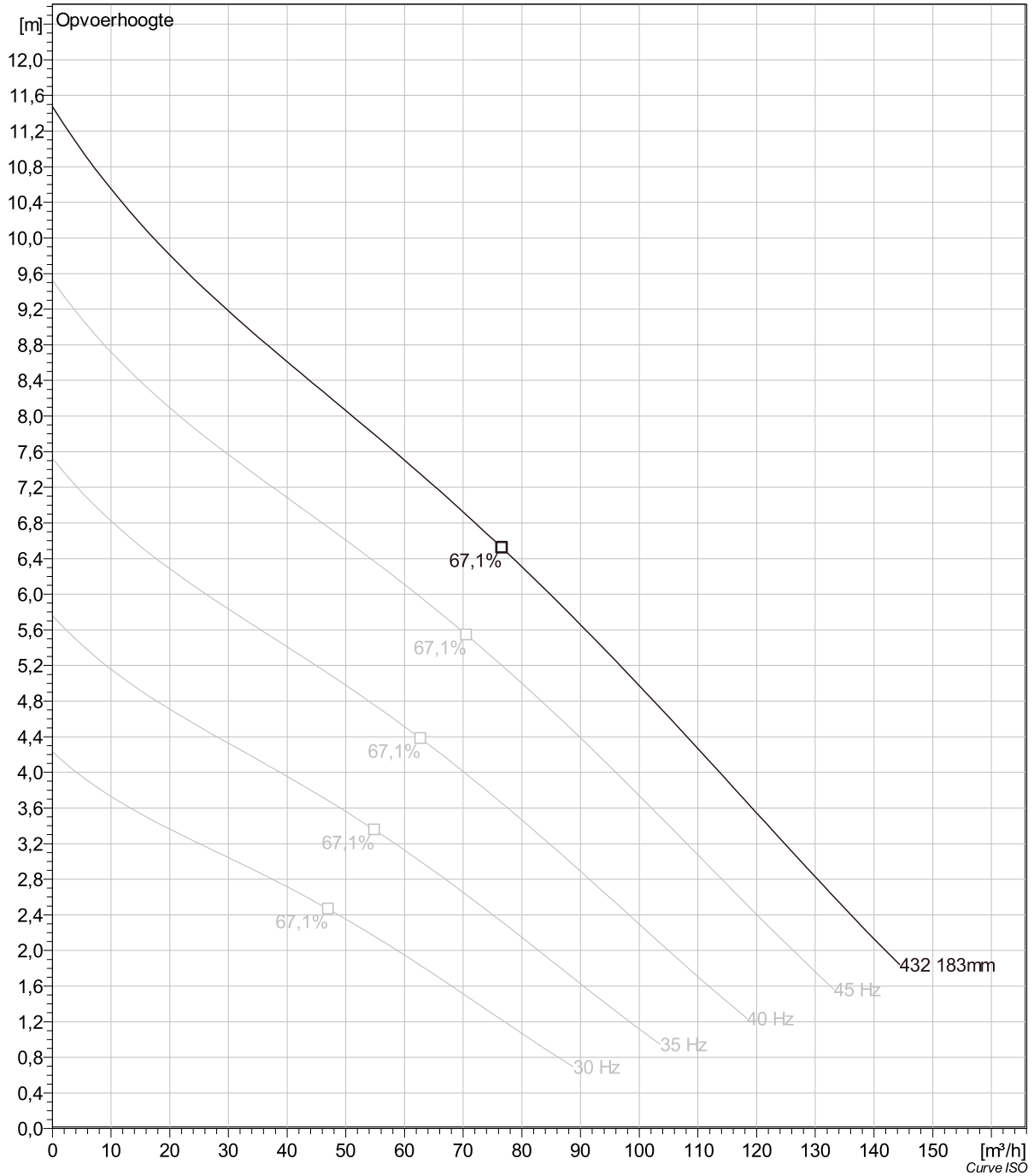

Project omschrijving	Projectnummer	Aangemaakt door:	Aangemaakt op 9/27/2018	Laatste wijziging
----------------------	---------------	------------------	----------------------------	-------------------

CP 3102 MT 3~ 432 Dimensional drawing

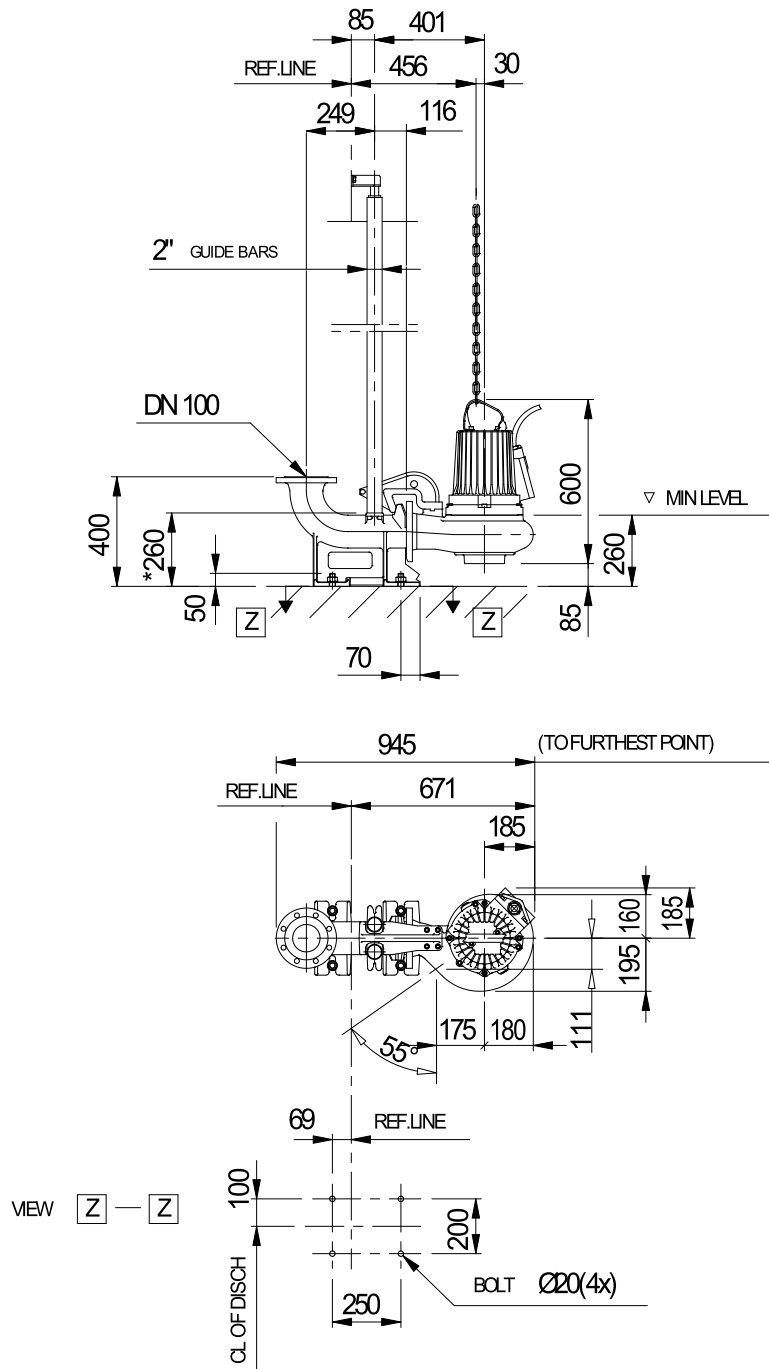

Weight

* DIMENSION TO ENDS OF GUIDE BARS

Dimensional dwg
CP 3102 MT

Project omschrijving	Projectnummer	Aangemaakt door:	Aangemaakt op 9/27/2018	Laatste wijziging
----------------------	---------------	------------------	----------------------------	-------------------