

## CS 3102 MT 3~ 433 Technische specificaties

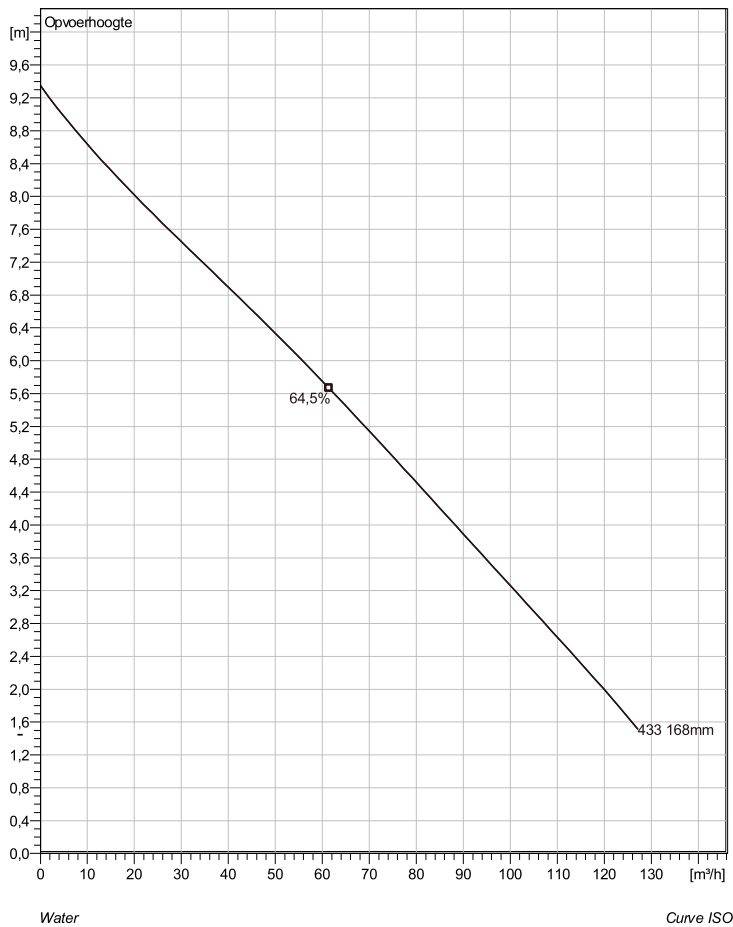

Soort installatie: Semi permanent, Nat

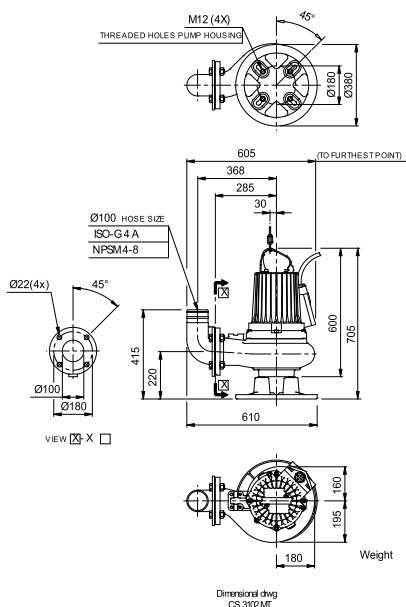

Note: Picture might not correspond to the current configuration.

### General

Dompelbare pompen voorzien van één of meerkanaalwaaier met grote doorlaat. Geschikt voor afvalwater met grotere delen zoals rioolwater, regenwater en industrieel afvalwater. Materiaal gietijzer.

### Impeller

Impeller material	Grey cast iron
Persaansluiting	100 mm
Diameter aanzuigzijde	100 mm
Impeller diameter	168 mm
Aantal bladen	1
Throughlet diameter	76 mm

### Motor

Motor #	C3102.181 18-11-4AL-W 3.1KW standaard
Stator variant	66
Frequentie	50 Hz
Nominale spanning	190 V
Aantal polen	4
Fasen	3~
Nominaal vermogen	3,1 kW
Toegekende stroom	13 A
Aanloopstroom	71 A
Nominaal toerental	1440 rpm
Vermogensfactor	
1/1 Load	0,84
3/4 Load	0,79
1/2 Load	0,68
Motor efficiency	
1/1 Load	83,5 %
3/4 Load	85,0 %
1/2 Load	84,0 %

Project omschrijving	Projectnummer	Aangemaakt door:	Aangemaakt op 10/3/2018	Laatste wijziging
----------------------	---------------	------------------	----------------------------	-------------------

## CS 3102 MT 3~ 433

### Karakteristiek

#### Pomp

Persaansluiting	100 mm
Diameter aanzuigzijde	100 mm
Impeller diameter	168 mm
Aantal bladen	1
Throughlet diameter	76 mm

#### Motor

Motor #	C3102.181 18-11-4AL-W 3.1KW
Stator variant	66
Frequentie	50 Hz
Nominale spanning	190 V
Aantal polen	4
Fasen	3~
Nominaal vermogen	3,1 kW
Toegekende stroom	13 A
Aanloopstroom	71 A
Nominaal toerental	1440 rpm

Vermogensfactor	
1/1 Load	0,84
3/4 Load	0,79
1/2 Load	0,68
Motor efficiency	
1/1 Load	83,5 %
3/4 Load	85,0 %
1/2 Load	84,0 %

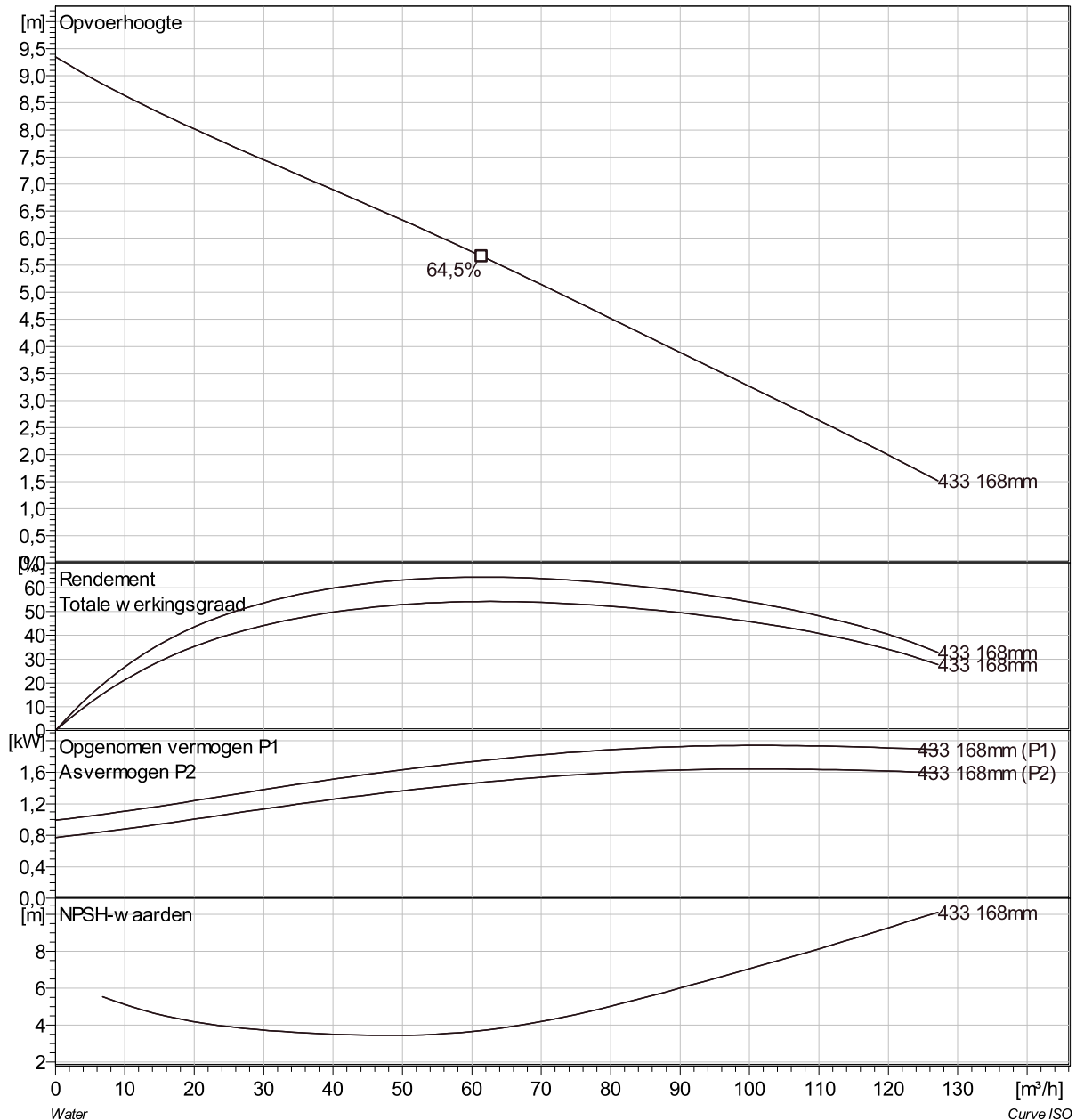

Project omschrijving	Projectnummer	Aangemaakt door:	Aangemaakt op 10/3/2018	Laatste wijziging
----------------------	---------------	------------------	----------------------------	-------------------

## CS 3102 MT 3~ 433 VFD Analysis

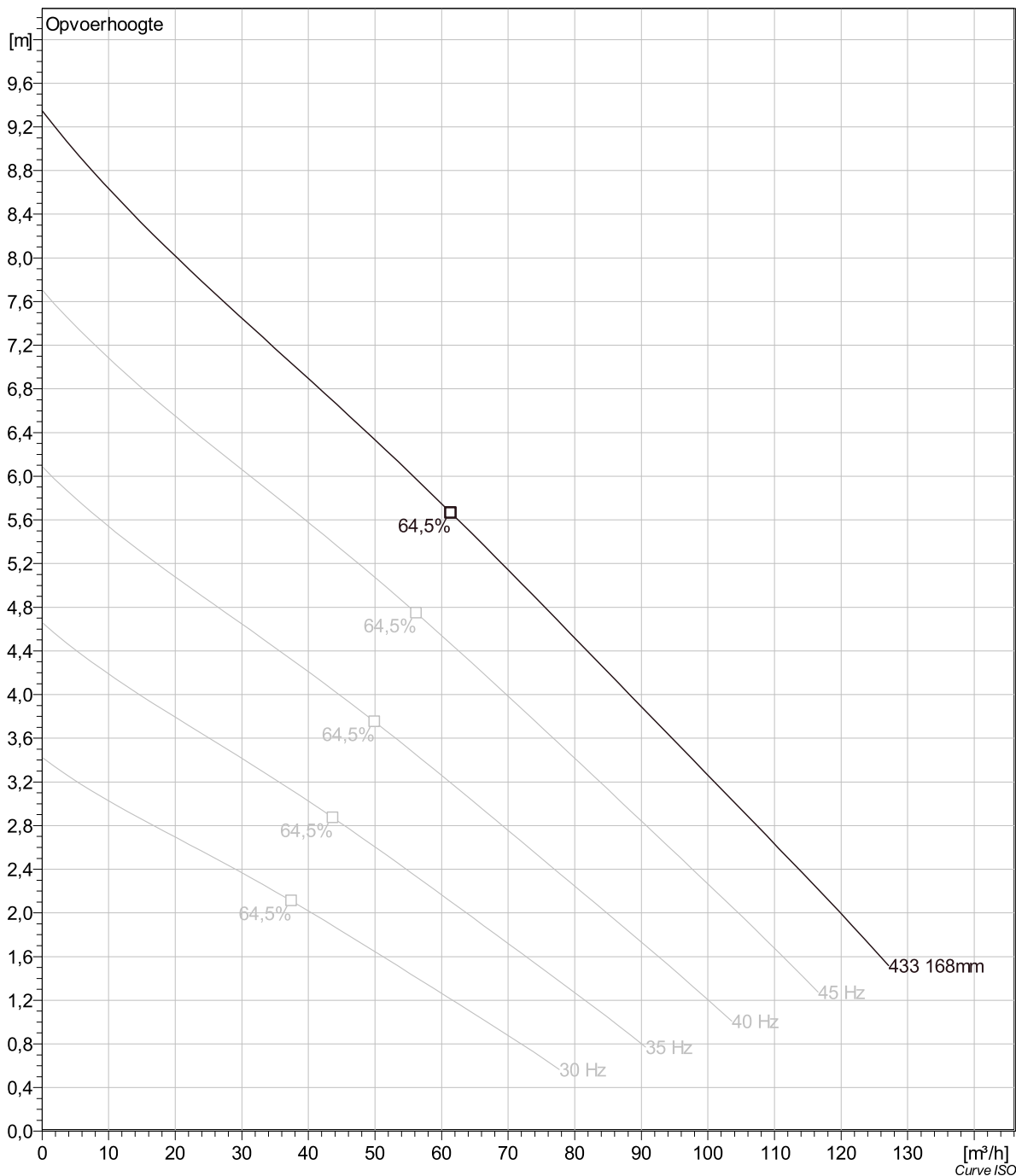

Project omschrijving	Projectnummer	Aangemaakt door:	Aangemaakt op <b>10/3/2018</b>	Laatste wijziging
----------------------	---------------	------------------	-----------------------------------	-------------------

## CS 3102 MT 3~ 433 Dimensional drawing

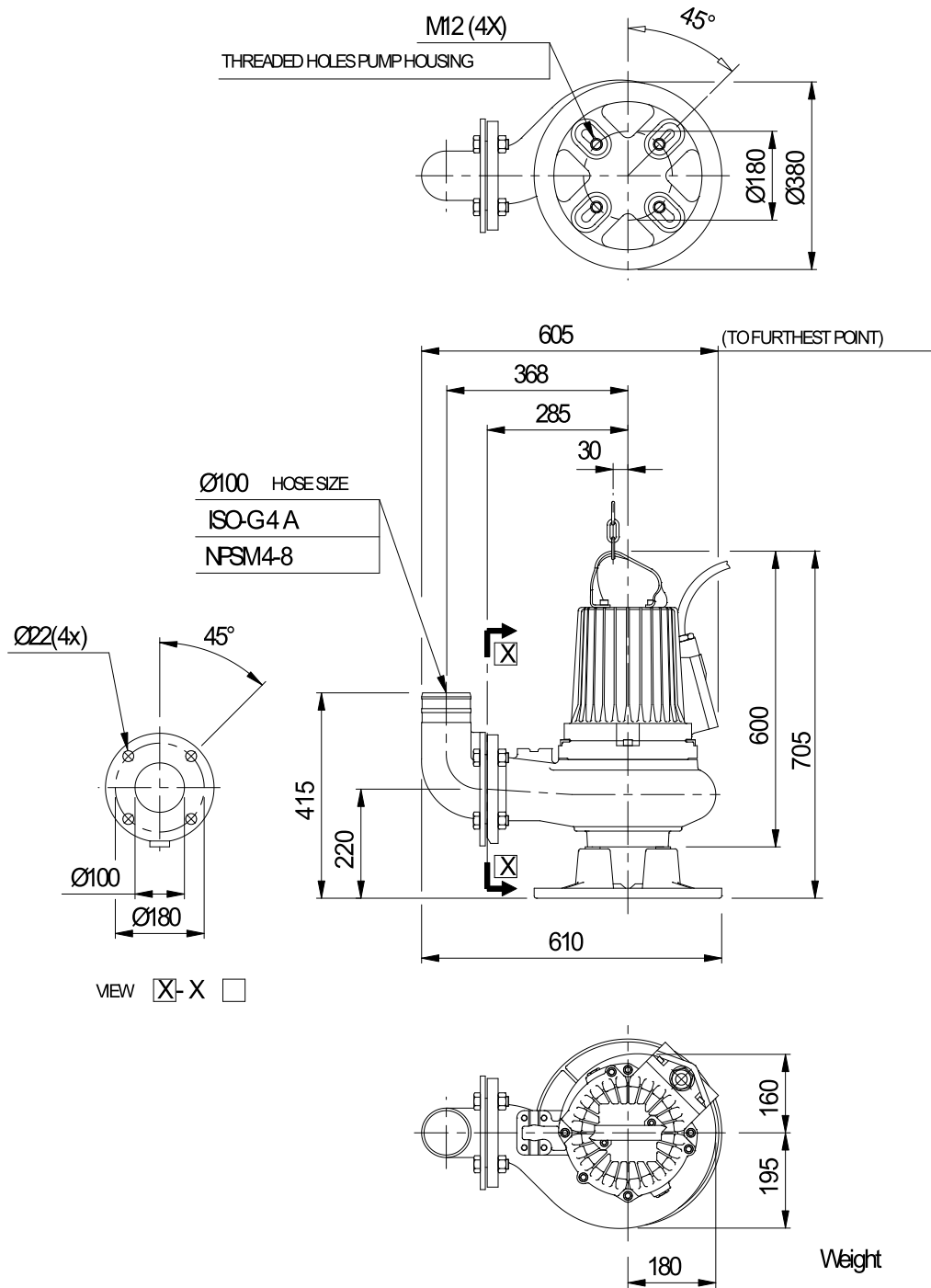

Dimensional drwg  
CS3102MT

Project omschrijving	Projectnummer	Aangemaakt door:	Aangemaakt op 10/3/2018	Laatste wijziging
----------------------	---------------	------------------	----------------------------	-------------------