

CP 3127 LT 3~ 411 Technische specificaties

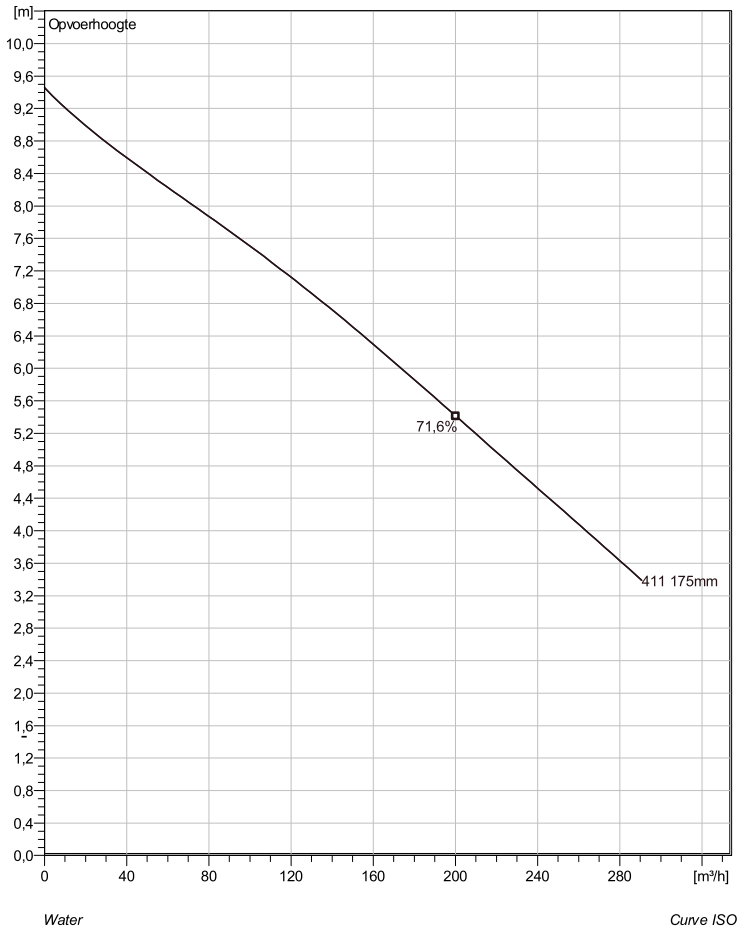

Soort installatie: Semi Permanent, Nat

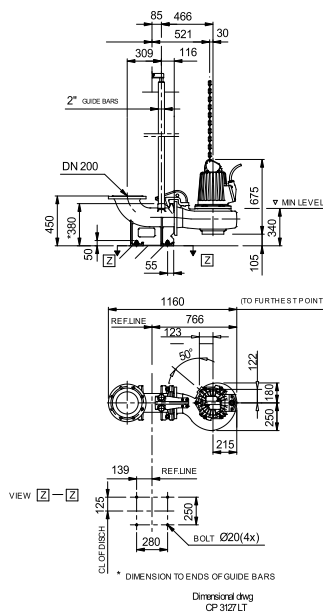

Note: Picture might not correspond to the current configuration.

General

Dompelpbare pompen voorzien van één of meerkanaalwaaijer met grote doorlaat. Geschikt voor afvalwater met grotere delen zoals rioolwater, regenwater en industrieel afvalwater. Materiaal gietijzer.

Impeller

Impeller material	Grey cast iron
Persaansluiting	150 mm
Diameter aanzuigzijde	150 mm
Impeller diameter	175 mm
Aantal bladen	2
Throughlet diameter	76 mm

Motor

Motor #	C3127.182 21-10-4AL-W 4.7KW standaard
Stator variant	28
Frequentie	50 Hz
Nominale spanning	190 V
Aantal polen	4
Fasen	3~
Nominaal vermogen	4,7 kW
Toegekende stroom	21 A
Aanloopstroom	138 A
Nominaal toerental	1450 rpm
Vermogensfactor	
1/1 Load	0,82
3/4 Load	0,76
1/2 Load	0,65
Motor efficiency	
1/1 Load	82,4 %
3/4 Load	82,3 %
1/2 Load	79,8 %

Project	Project ID	Created by	Created on 9/28/2018	Last update
---------	------------	------------	-------------------------	-------------

CP 3127 LT 3~ 411



Karakteristiek

Pomp

Persaansluiting	150 mm
Diameter aanzuigzijde	150 mm
Impeller diameter	175 mm
Aantal bladen	2
Throughlet diameter	76 mm

Motor

Motor #	C3127.182 21-10-4AL-W 4.7KW
Stator variant	28
Frequentie	50 Hz
Nominale spanning	190 V
Aantal polen	4
Fasen	3~
Nominaal vermogen	4,7 kW
Toegekende stroom	21 A
Aanloopstroom	138 A
Nominaal toerental	1450 rpm

Vermogensfactor	
1/1 Load	0,82
3/4 Load	0,76
1/2 Load	0,65
Motor efficiency	
1/1 Load	82,4 %
3/4 Load	82,3 %
1/2 Load	79,8 %

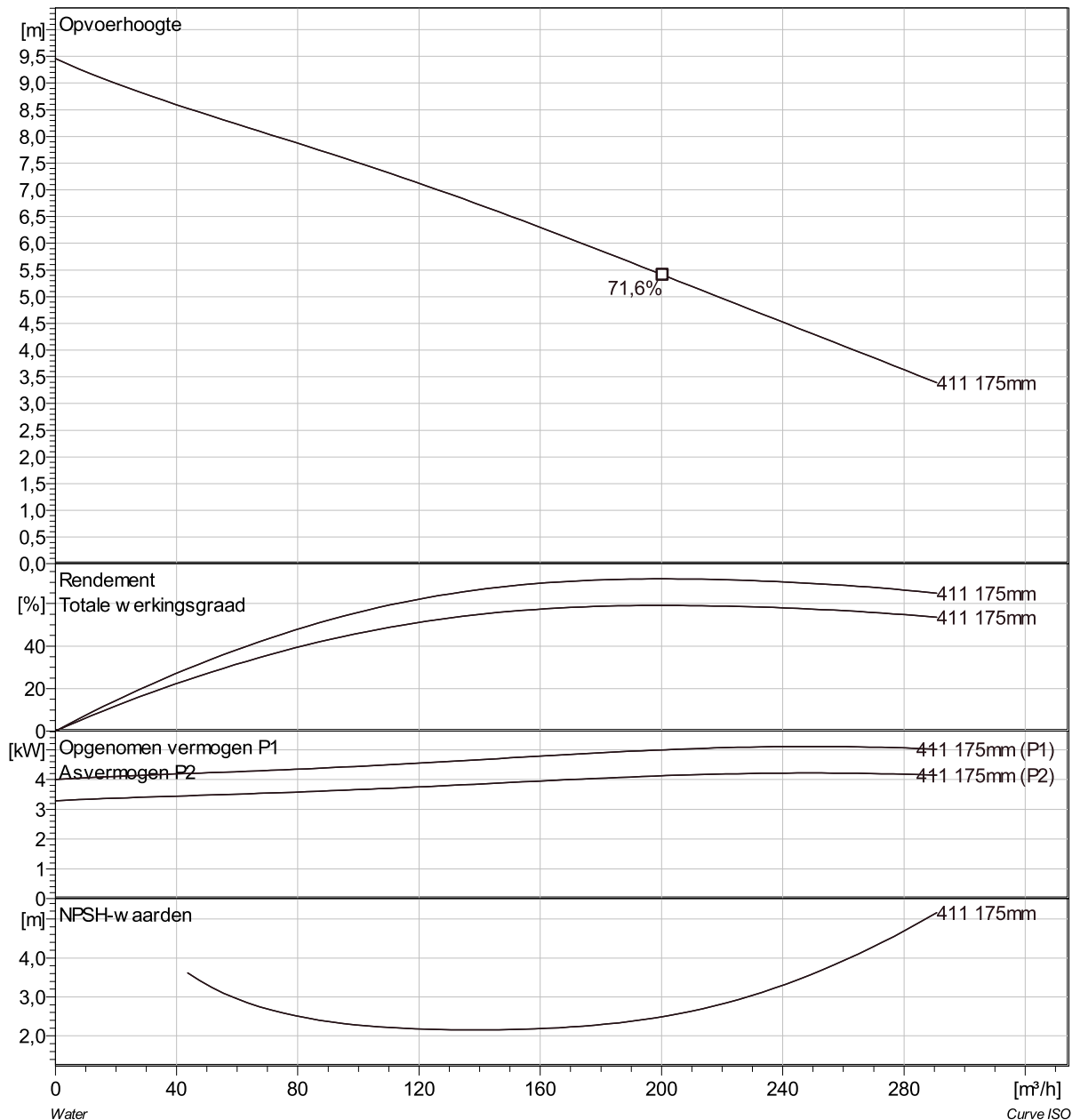

Project	Project ID	Created by	Created on 9/28/2018	Last update
---------	------------	------------	-------------------------	-------------

CP 3127 LT 3~ 411 VFD Analysis

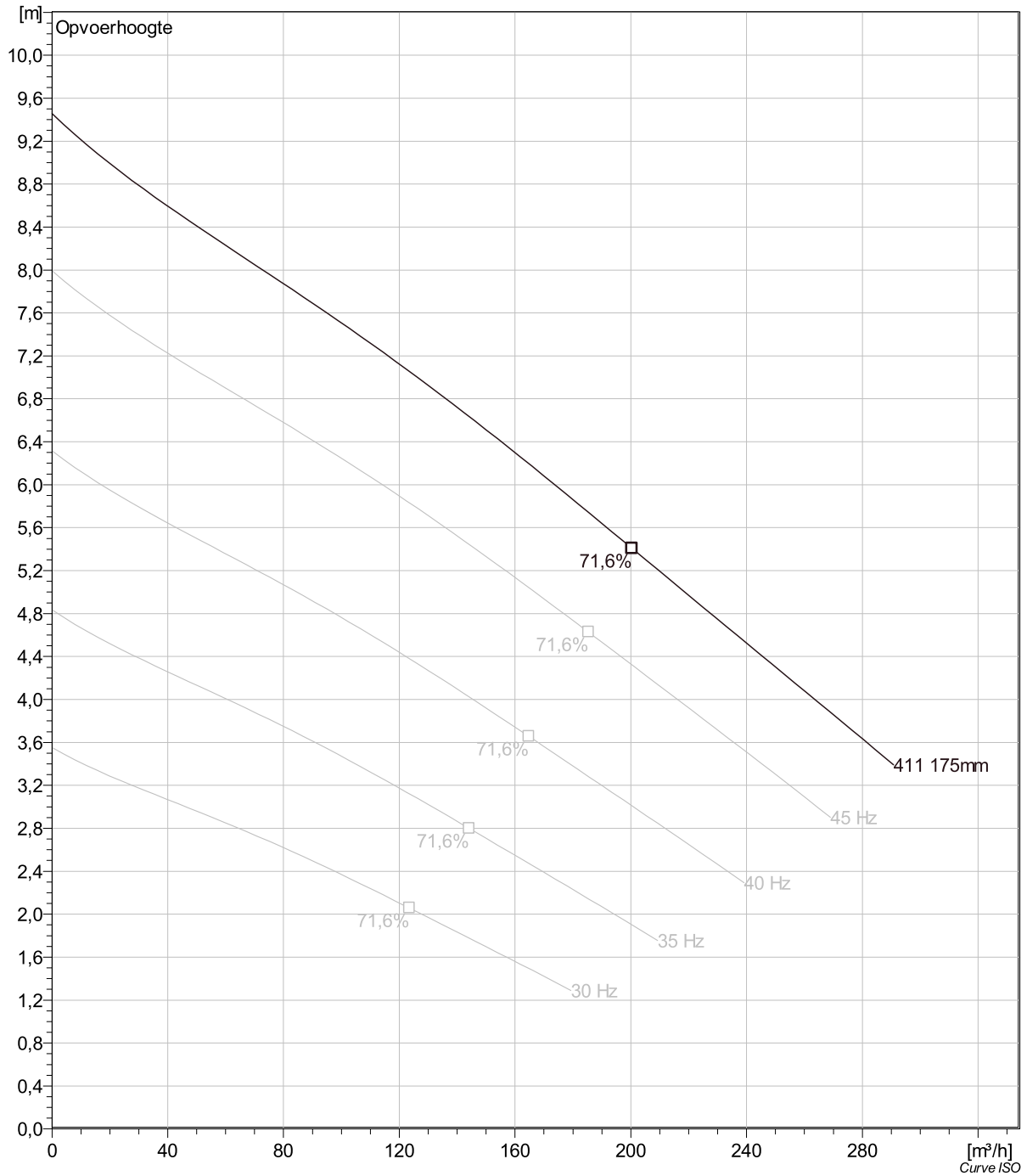

Project	Project ID	Created by	Created on	Last update
			9/28/2018	

CP 3127 LT 3~ 411 Dimensional drawing

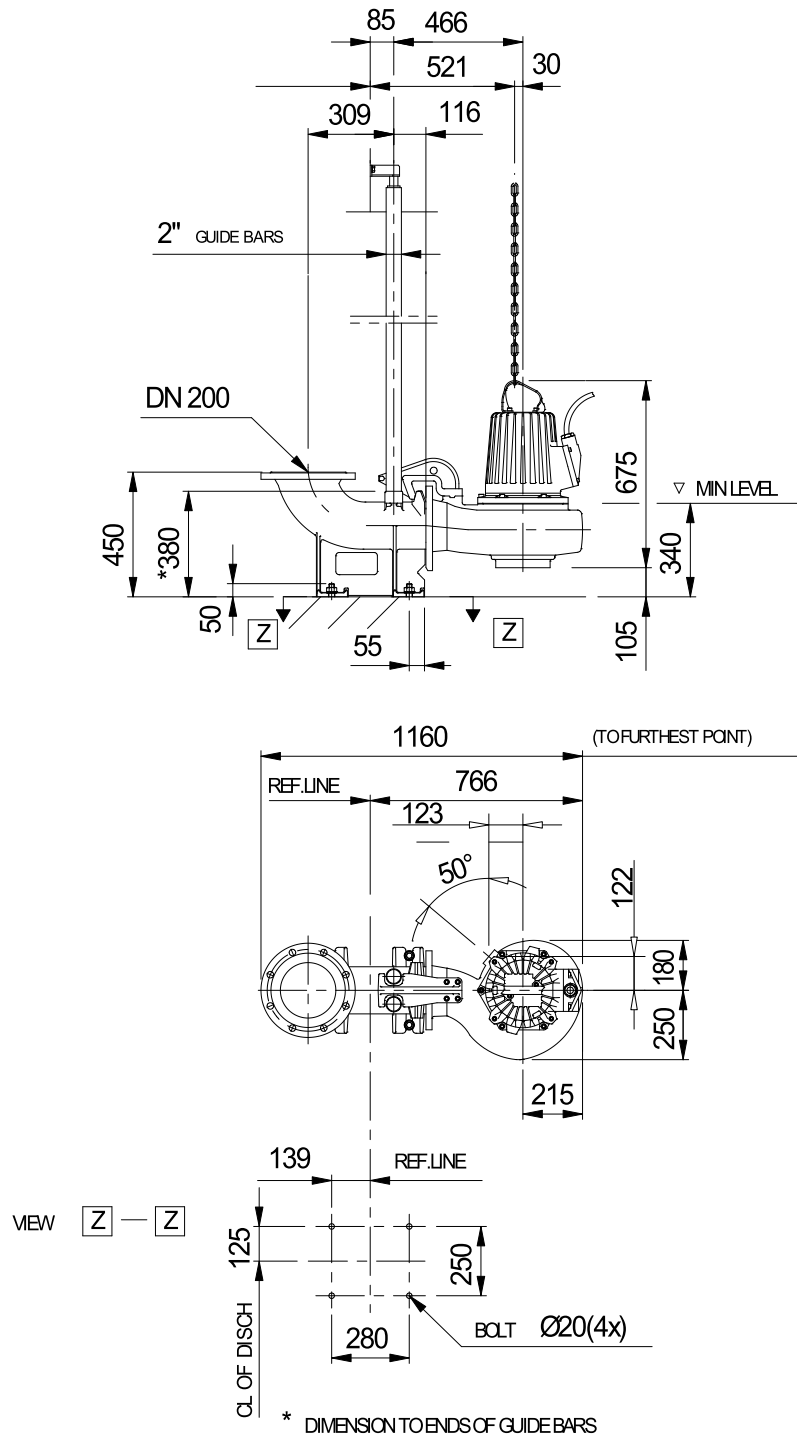

Dimensional drwg
CP3127LT

Project	Project ID	Created by	Created on	Last update
			9/28/2018	