

## CS 3127 HT 3~ 250

### Technische specificaties

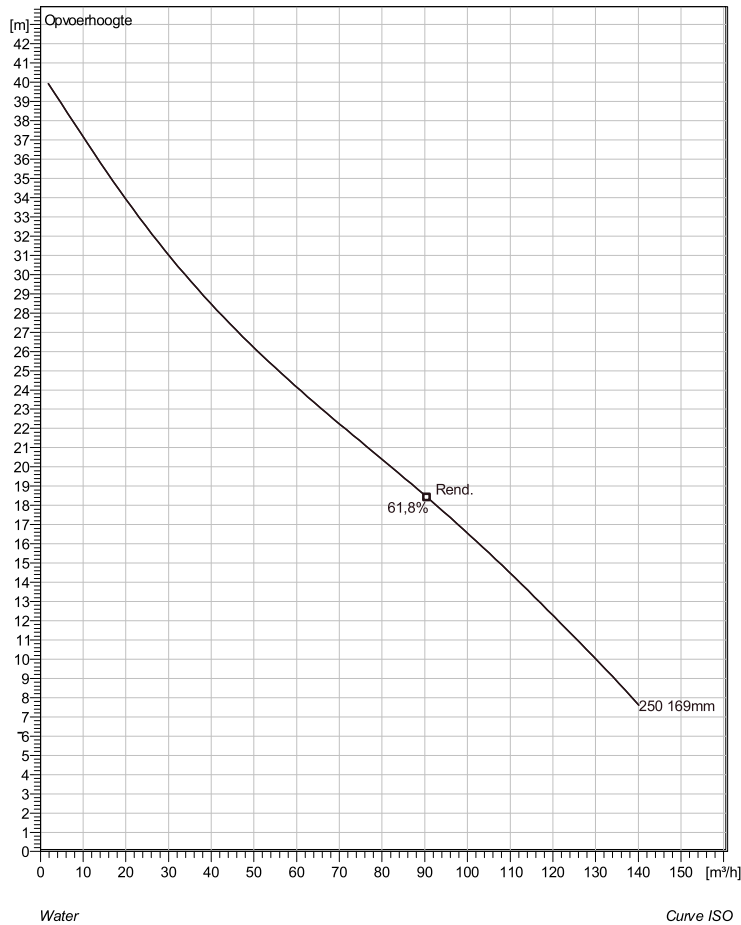

Note: Picture might not correspond to the current configuration.

#### General

Dompelbare pompen voorzien van één of meerkanaalwaaier met grote doorlaat. Geschikt voor afvalwater met grotere delen zoals rioolwater, regenwater en industrieel afvalwater. Materiaal gietijzer.

#### Impeller

Impeller material	Grey cast iron
Persaansluiting	80 mm
Diameter aanzuigzijde	100 mm
Impeller diameter	169 mm
Aantal bladen	1

#### Motor

Motor #	C3127.182 21-11-2AL-W 7.4KW standaard
Stator variant	28
Frequentie	50 Hz
Nominale spanning	190 V
Aantal polen	2
Fasen	3~
Nominaal vermogen	7,4 kW
Toegekende stroom	30 A
Aanloopstroom	274 A
Nominaal toerental	2910 rpm
Vermogensfactor	
1/1 Load	0,85
3/4 Load	0,79
1/2 Load	0,69
Motor efficiency	
1/1 Load	87,5 %
3/4 Load	87,9 %
1/2 Load	86,7 %

#### Soort installatie: Semi permanent, Nat

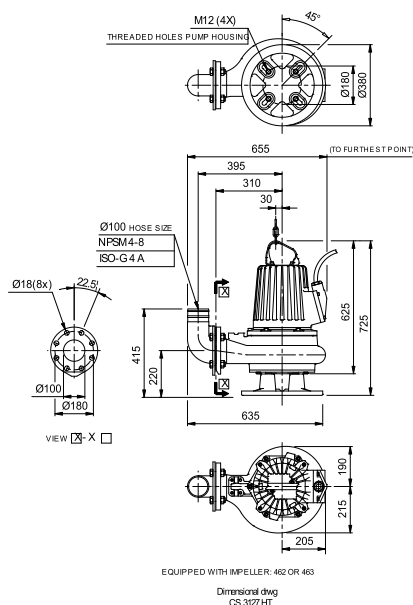

Project omschrijving	Projectnummer	Aangemaakt door:	Aangemaakt op 10/3/2018	Laatste wijziging
----------------------	---------------	------------------	----------------------------	-------------------

## CS 3127 HT 3~ 250

### Karakteristiek

#### Pomp

Persaansluiting	80 mm
Diameter aanzuigzijde	100 mm
Impeller diameter	169 mm
Aantal bladen	1

#### Motor

Motor #	C3127.182 21-11-2AL-W 7.4KW
Stator variant	28
Frequentie	50 Hz
Nominale spanning	190 V
Aantal polen	2
Fasen	3~
Nominaal vermogen	7,4 kW
Toegekende stroom	30 A
Aanloopstroom	274 A
Nominaal toerental	2910 rpm

Vermogensfactor	
1/1 Load	0,85
3/4 Load	0,79
1/2 Load	0,69
Motor efficiency	
1/1 Load	87,5 %
3/4 Load	87,9 %
1/2 Load	86,7 %

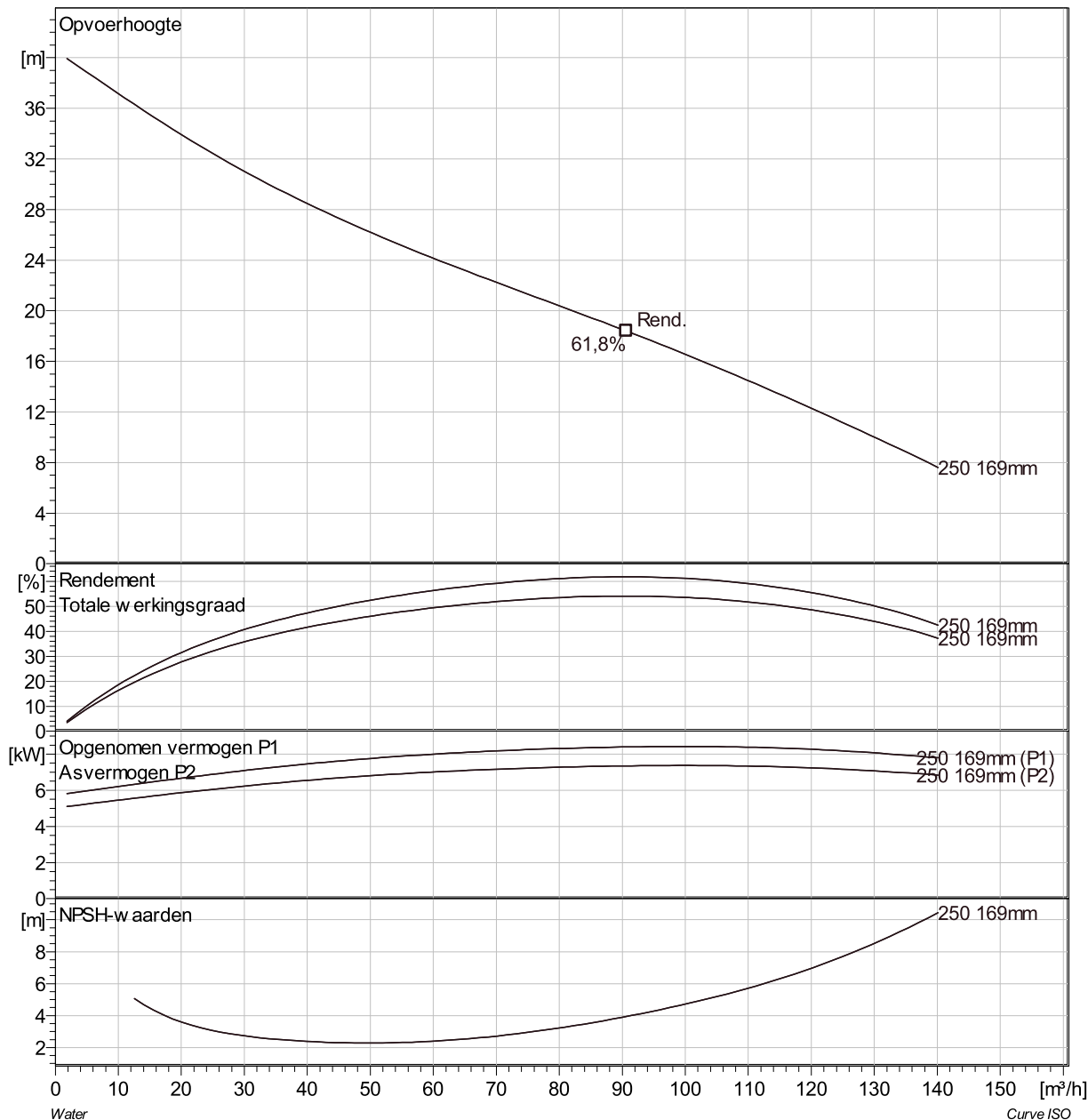

Project omschrijving	Projectnummer	Aangemaakt door:	Aangemaakt op 10/3/2018	Laatste wijziging
----------------------	---------------	------------------	----------------------------	-------------------

## CS 3127 HT 3~ 250 VFD Analysis

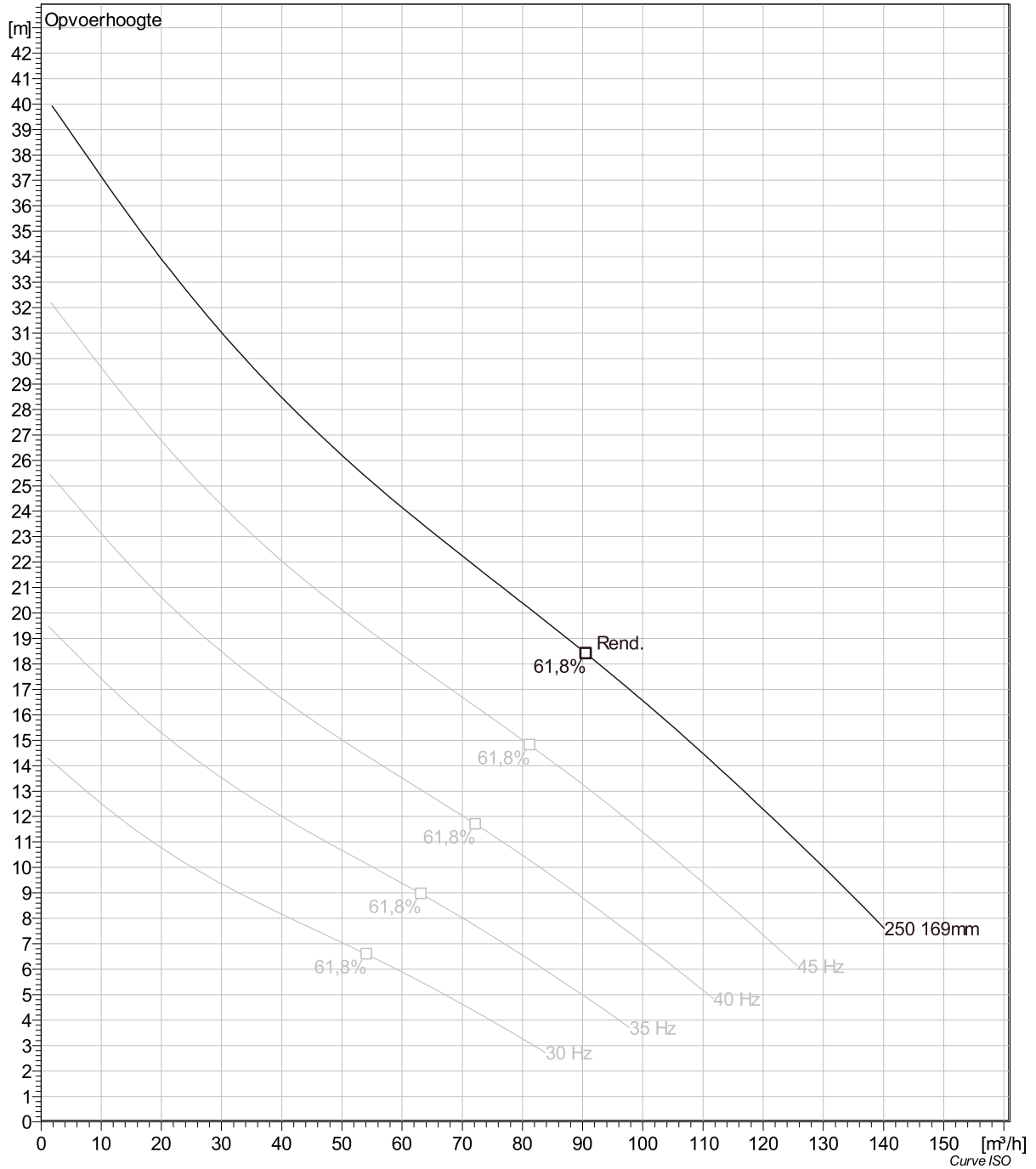

Project omschrijving	Projectnummer	Aangemaakt door:	Aangemaakt op <b>10/3/2018</b>	Laatste wijziging
----------------------	---------------	------------------	-----------------------------------	-------------------

## CS 3127 HT 3~ 250 Dimensional drawing

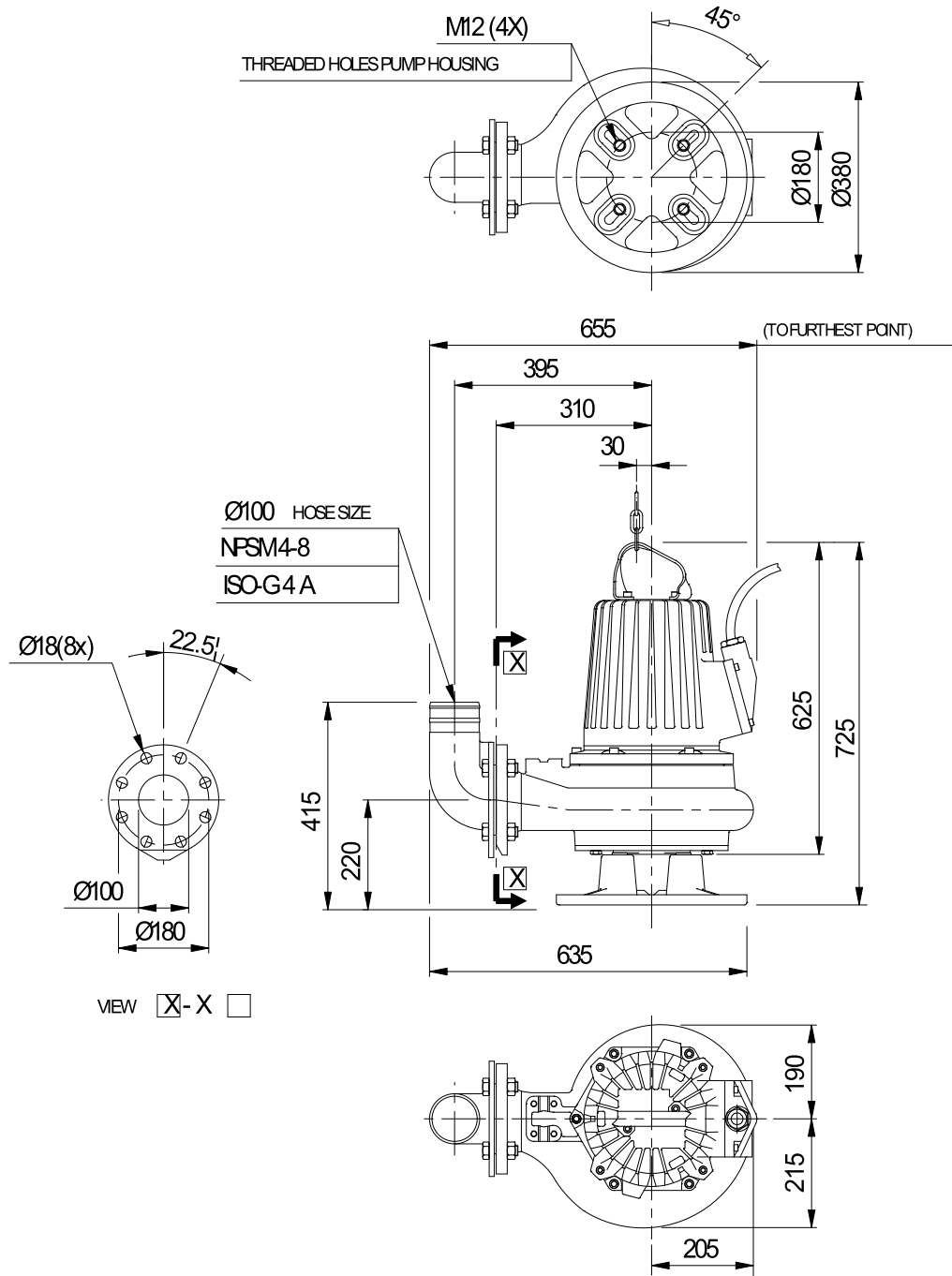

EQUIPPED WITH IMPELLER: 462 OR 463

Dimensional dwg  
CS3127 HT

Project omschrijving	Projectnummer	Aangemaakt door:	Aangemaakt op 10/3/2018	Laatste wijziging
----------------------	---------------	------------------	----------------------------	-------------------