

CS 3127 HT 3~ 480 Technische specificaties

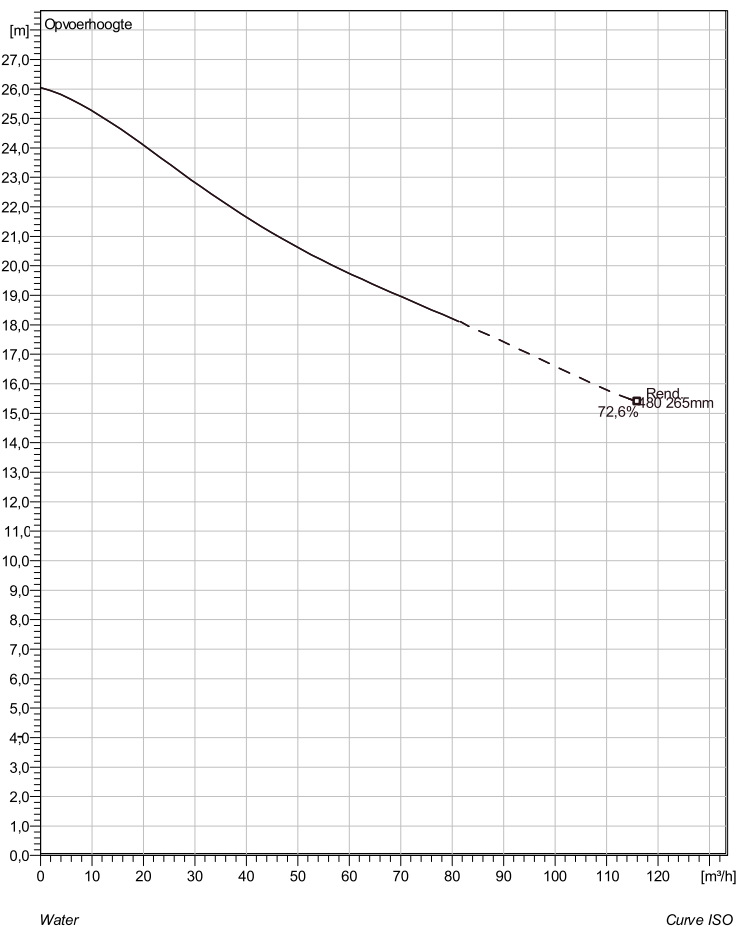

Note: Picture might not correspond to the current configuration.

General

Dompelbare pompen voorzien van één of meerkanaalwaaier met grote doorlaat. Geschikt voor afvalwater met grotere delen zoals rioolwater, regenwater en industrieel afvalwater. Materiaal gietijzer.

Impeller

Impeller material	Grey cast iron
Persaansluiting	100 mm
Diameter aanzuigzijde	100 mm
Impeller diameter	265 mm
Aantal bladen	1
Throughlet diameter	76 mm

Motor

Motor #	C3127.182 21-12-4AL-W 5.9KW standaard
Stator variant	28
Frequentie	50 Hz
Nominale spanning	190 V
Aantal polen	4
Fasen	3~
Nominaal vermogen	5,9 kW
Toegekende stroom	26 A
Aanloopstroom	171 A
Nominaal toerental	1455 rpm
Vermogensfactor	
1/1 Load	0,83
3/4 Load	0,78
1/2 Load	0,67
Motor efficiency	
1/1 Load	84,6 %
3/4 Load	84,6 %
1/2 Load	82,4 %

Soort installatie: Semi permanent, Nat

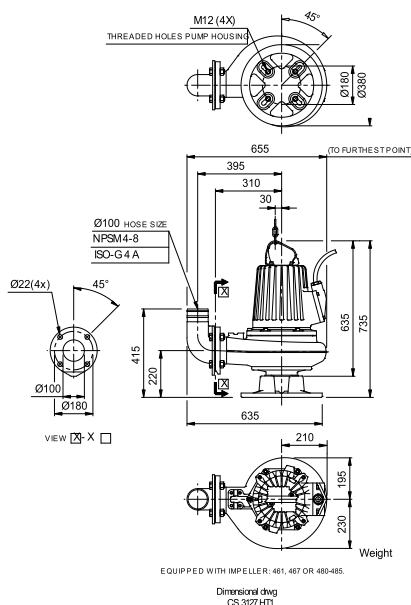

Project omschrijving	Projectnummer	Aangemaakt door:	Aangemaakt op 10/3/2018	Laatste wijziging
----------------------	---------------	------------------	----------------------------	-------------------

CS 3127 HT 3~ 480

Karakteristiek

Pomp

Persaansluiting	100 mm
Diameter aanzuigzijde	100 mm
Impeller diameter	265 mm
Aantal bladen	1
Throughlet diameter	76 mm

Motor

Motor #	C3127.182 21-12-4AL-W 5.9KW
Stator variant	28
Frequentie	50 Hz
Nominale spanning	190 V
Aantal polen	4
Fasen	3~
Nominaal vermogen	5,9 kW
Toegekende stroom	26 A
Aanloopstroom	171 A
Nominaal toerental	1455 rpm

Vermogensfactor	
1/1 Load	0,83
3/4 Load	0,78
1/2 Load	0,67
Motor efficiency	
1/1 Load	84,6 %
3/4 Load	84,6 %
1/2 Load	82,4 %

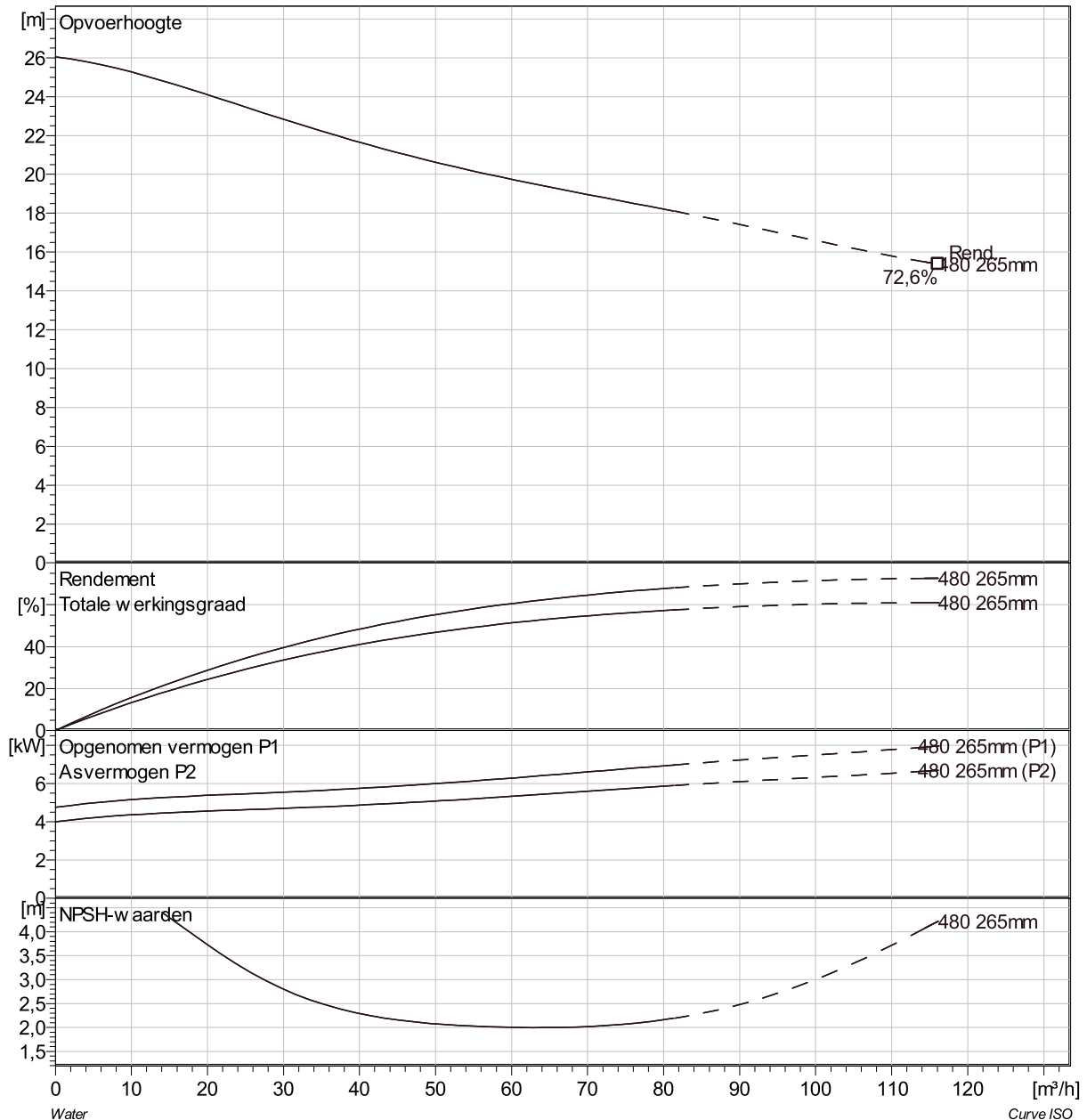

Project omschrijving	Projectnummer	Aangemaakt door:	Aangemaakt op 10/3/2018	Laatste wijziging
----------------------	---------------	------------------	----------------------------	-------------------

CS 3127 HT 3~ 480 VFD Analysis

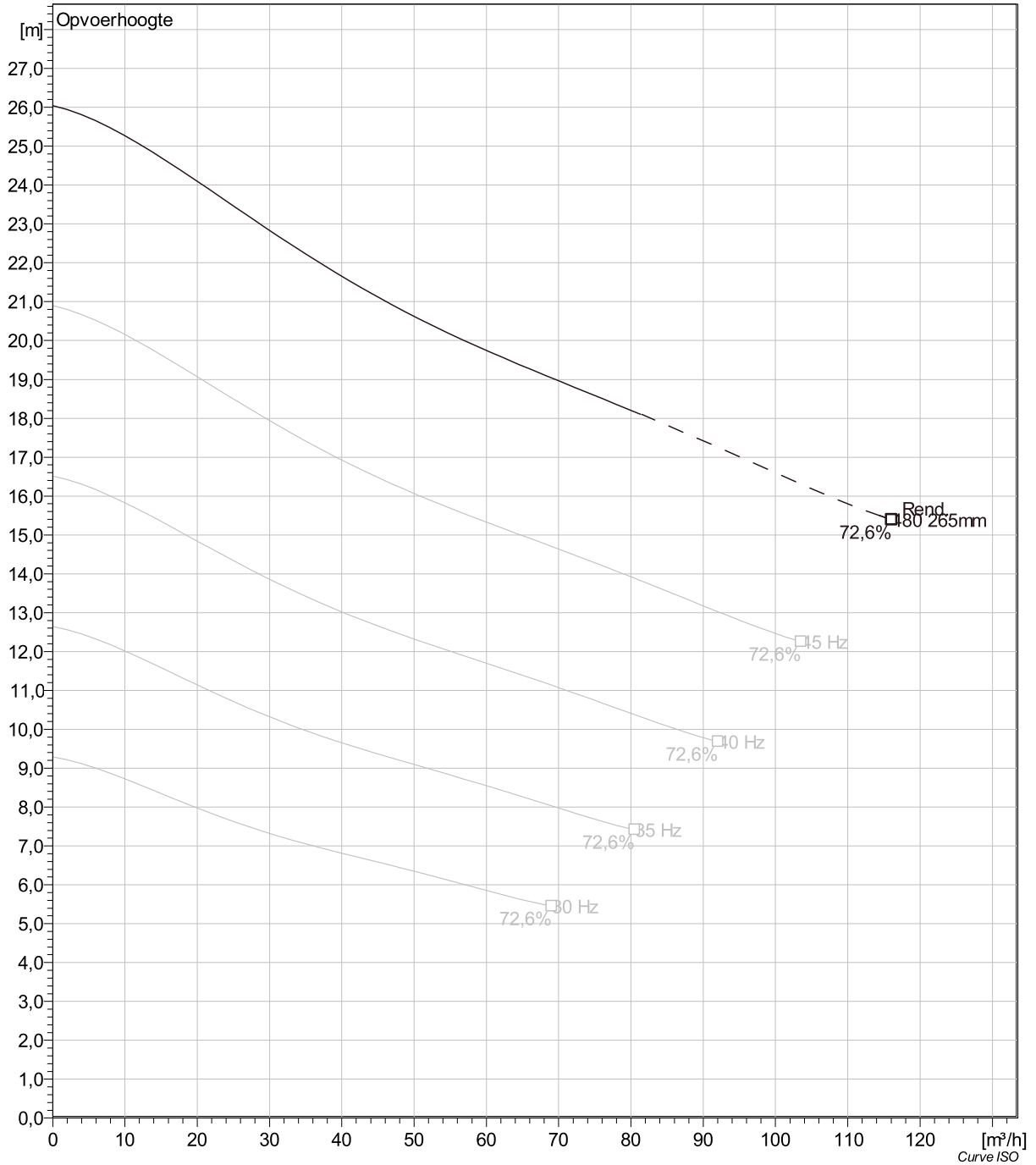

Project omschrijving	Projectnummer	Aangemaakt door:	Aangemaakt op 10/3/2018	Laatste wijziging
----------------------	---------------	------------------	-----------------------------------	-------------------

CS 3127 HT 3~ 480 Dimensional drawing

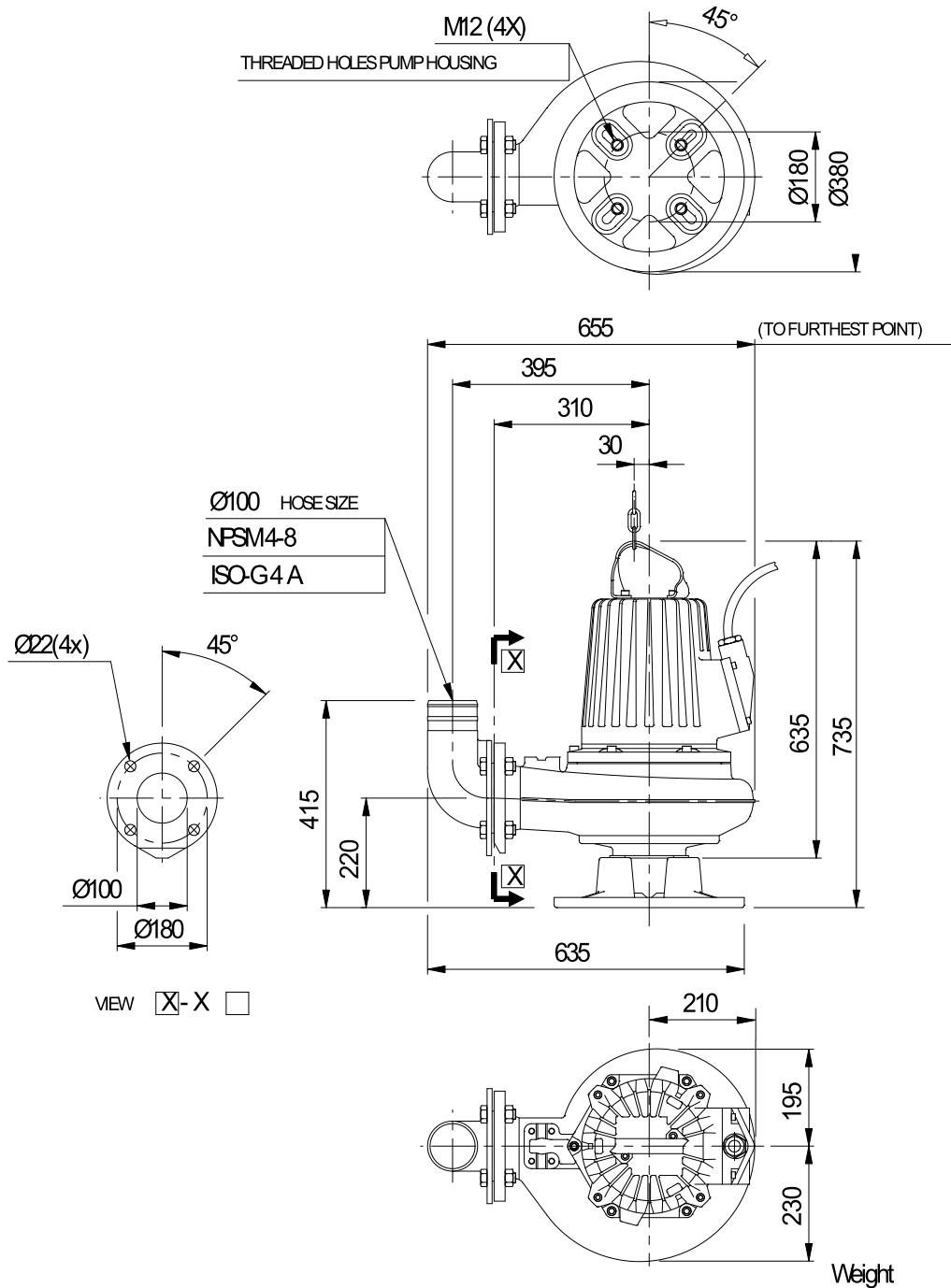

EQUIPPED WITH IMPELLER 461, 467 OR 480-485.

Dimensional drwg
CS 3127 HT1

Project omschrijving	Projectnummer	Aangemaakt door:	Aangemaakt op 10/3/2018	Laatste wijziging
----------------------	---------------	------------------	----------------------------	-------------------