

## CS 3127 LT 3~ 441 Technische specificaties

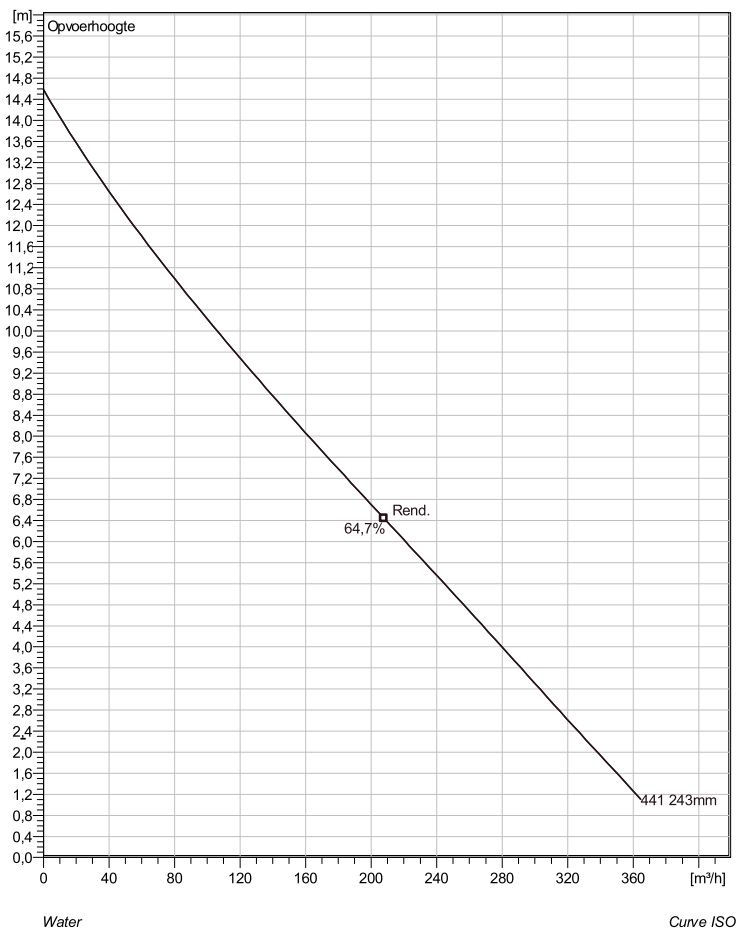

Soort installatie: Semi permanent, Nat

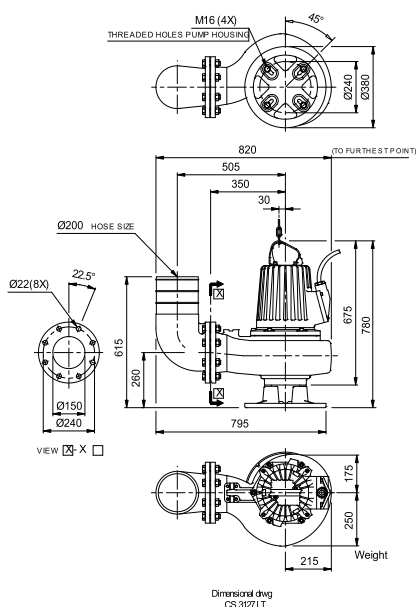

Note: Picture might not correspond to the current configuration.

### General

Dompelbare pompen voorzien van één of meerkanaalwaaier met grote doorlaat. Geschikt voor afvalwater met grotere delen zoals rioolwater, regenwater en industrieel afvalwater. Materiaal gietijzer.

### Impeller

Impeller material	Grey cast iron
Persaansluiting	150 mm
Diameter aanzuigzijde	150 mm
Impeller diameter	243 mm
Aantal bladen	1
Throughlet diameter	107 mm

### Motor

Motor #	C3127.182 21-12-4AL-W 5.9KW standaard
Stator variant	28
Frequentie	50 Hz
Nominale spanning	190 V
Aantal polen	4
Fasen	3~
Nominaal vermogen	5,9 kW
Toegekende stroom	26 A
Aanloopstroom	171 A
Nominaal toerental	1455 rpm
Vermogensfactor	
1/1 Load	0,83
3/4 Load	0,78
1/2 Load	0,67
Motor efficiency	
1/1 Load	84,6 %
3/4 Load	84,6 %
1/2 Load	82,4 %

Project omschrijving	Projectnummer	Aangemaakt door:	Aangemaakt op 10/3/2018	Laatste wijziging
----------------------	---------------	------------------	----------------------------	-------------------

## CS 3127 LT 3~ 441

### Karakteristiek

#### Pomp

Persaansluiting	150 mm
Diameter aanzuigzijde	150 mm
Impeller diameter	243 mm
Aantal bladen	1
Throughlet diameter	107 mm

#### Motor

Motor #	C3127.182 21-12-4AL-W 5.9KW
Stator variant	28
Frequentie	50 Hz
Nominale spanning	190 V
Aantal polen	4
Fasen	3~
Nominaal vermogen	5,9 kW
Toegekende stroom	26 A
Aanloopstroom	171 A
Nominaal toerental	1455 rpm

Vermogensfactor	
1/1 Load	0,83
3/4 Load	0,78
1/2 Load	0,67
Motor efficiency	
1/1 Load	84,6 %
3/4 Load	84,6 %
1/2 Load	82,4 %

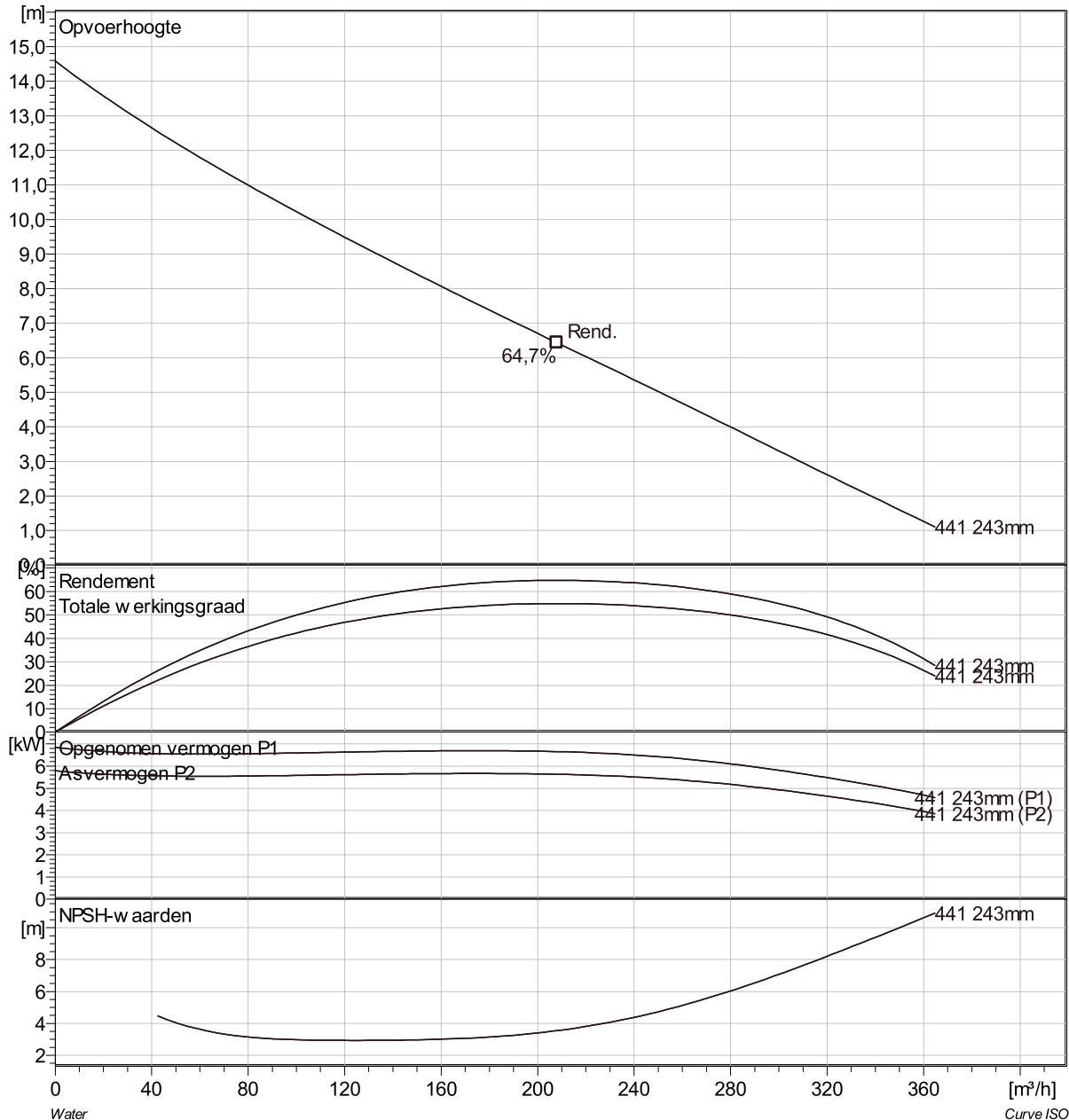

Project omschrijving	Projectnummer	Aangemaakt door:	Aangemaakt op 10/3/2018	Laatste wijziging
----------------------	---------------	------------------	----------------------------	-------------------

## CS 3127 LT 3~ 441 VFD Analysis

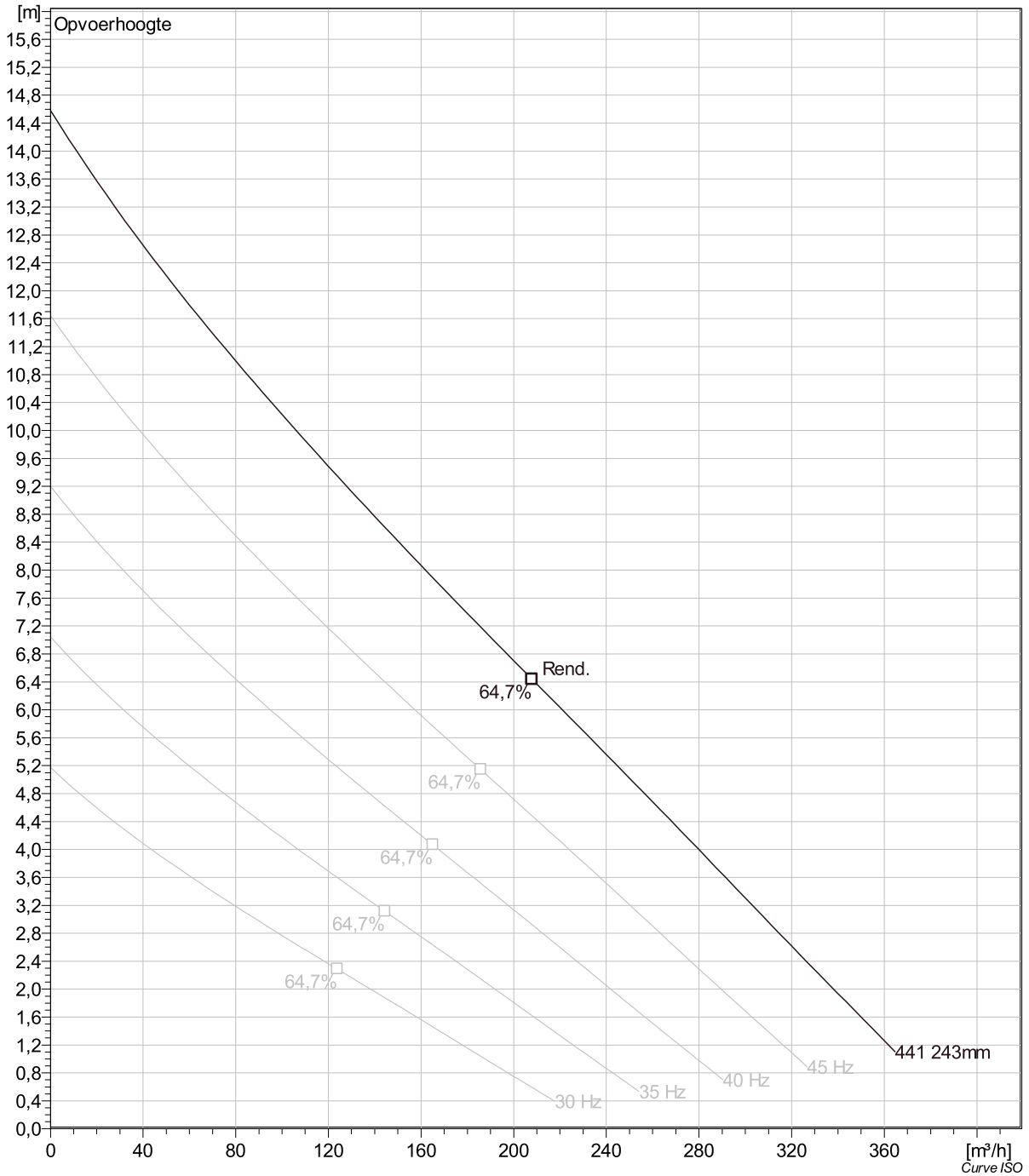

Project omschrijving	Projectnummer	Aangemaakt door:	Aangemaakt op <b>10/3/2018</b>	Laatste wijziging
----------------------	---------------	------------------	-----------------------------------	-------------------

## CS 3127 LT 3~ 441 Dimensional drawing

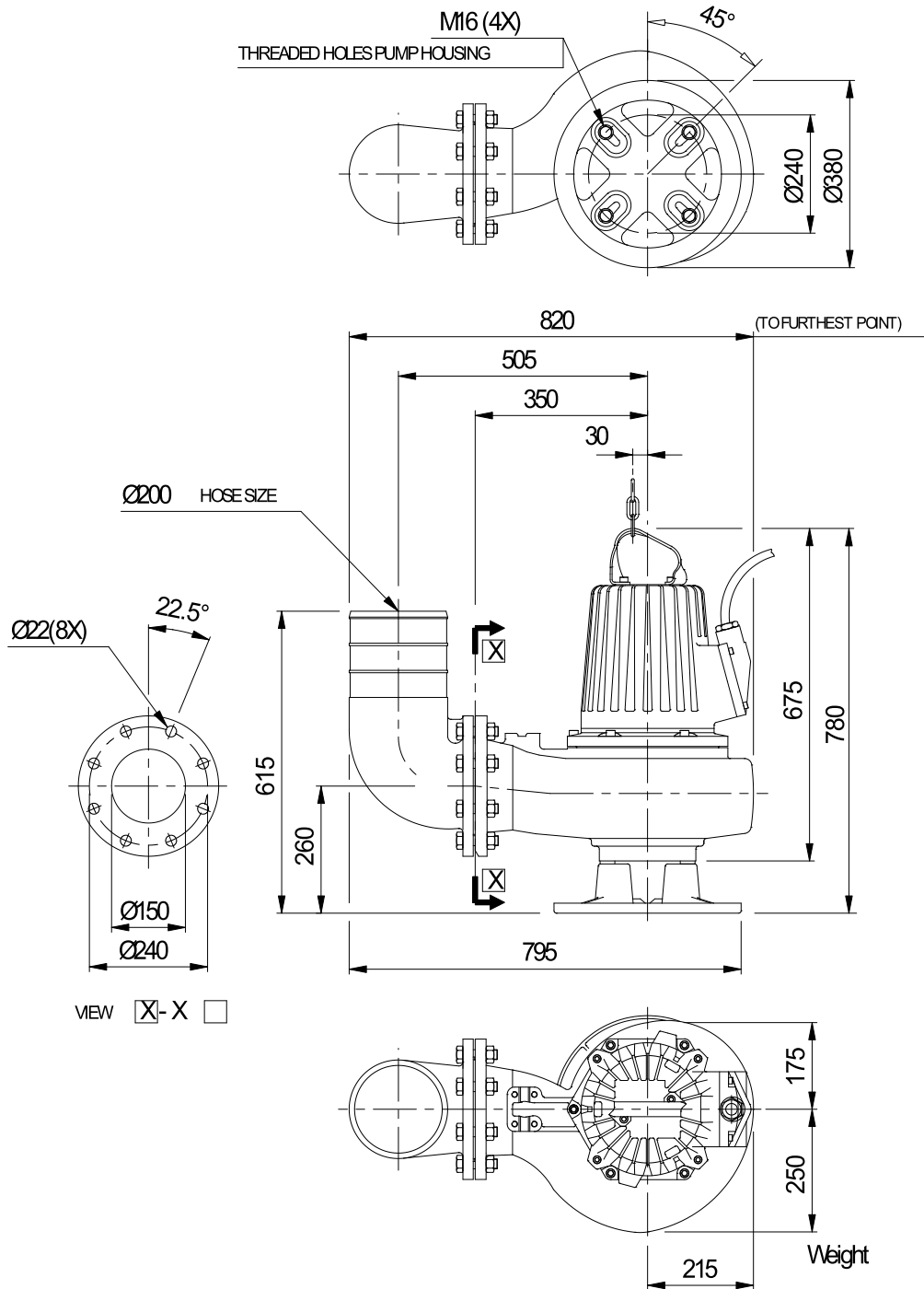

Dimensional dwg  
CS3127LT

Project omschrijving	Projectnummer	Aangemaakt door:	Aangemaakt op 10/3/2018	Laatste wijziging
----------------------	---------------	------------------	----------------------------	-------------------