

CS 3127 LT 3~ 442 Technische specificaties

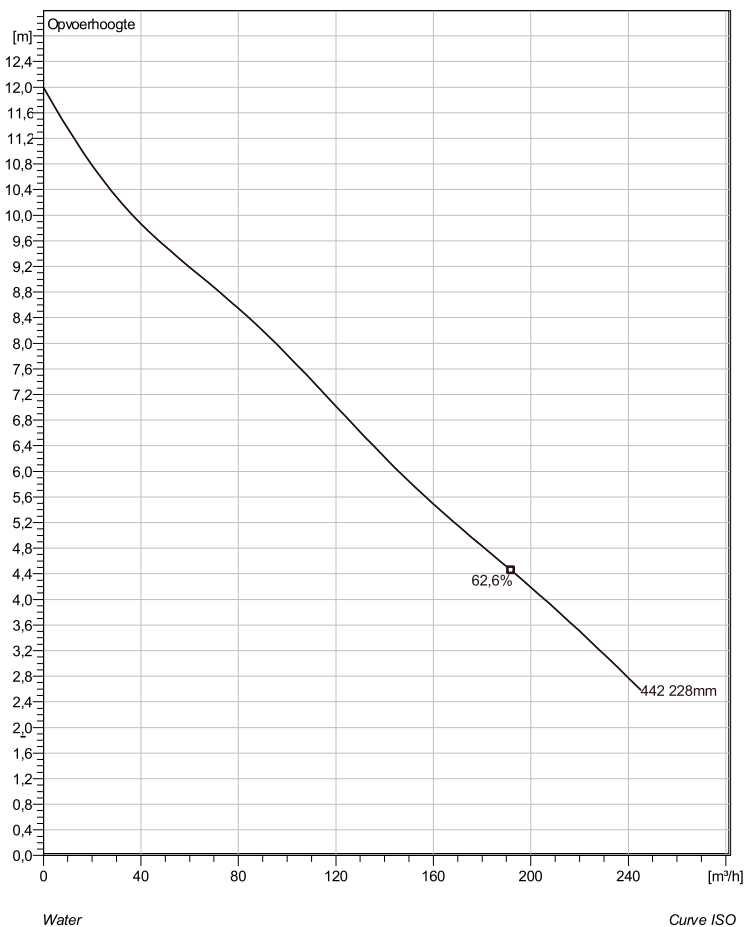

Soort installatie: Semi permanent, Nat

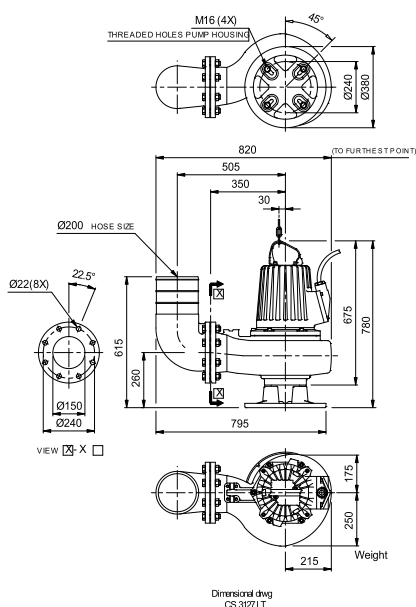

Note: Picture might not correspond to the current configuration.

General

Dompelbare pompen voorzien van één of meerkanaalwaaier met grote doorlaat. Geschikt voor afvalwater met grotere delen zoals rioolwater, regenwater en industrieel afvalwater. Materiaal gietijzer.

Impeller

Impeller material	Grey cast iron
Persaansluiting	150 mm
Diameter aanzuigzijde	150 mm
Impeller diameter	228 mm
Aantal bladen	1
Throughlet diameter	107 mm

Motor

Motor #	C3127.182 21-10-4AL-W 4.7KW standaard
Stator variant	28
Frequentie	50 Hz
Nominale spanning	190 V
Aantal polen	4
Fasen	3~
Nominaal vermogen	4,7 kW
Toegekende stroom	21 A
Aanloopstroom	138 A
Nominaal toerental	1450 rpm
Vermogensfactor	
1/1 Load	0,82
3/4 Load	0,76
1/2 Load	0,65
Motor efficiency	
1/1 Load	82,4 %
3/4 Load	82,3 %
1/2 Load	79,8 %

Project omschrijving	Projectnummer	Aangemaakt door:	Aangemaakt op 10/3/2018	Laatste wijziging
----------------------	---------------	------------------	----------------------------	-------------------

CS 3127 LT 3~ 442

Karakteristiek

Pomp

Persaansluiting	150 mm
Diameter aanzuigzijde	150 mm
Impeller diameter	228 mm
Aantal bladen	1
Throughlet diameter	107 mm

Motor

Motor #	C3127.182 21-10-4AL-W 4.7KW
Stator variant	28
Frequentie	50 Hz
Nominale spanning	190 V
Aantal polen	4
Fasen	3~
Nominaal vermogen	4,7 kW
Toegekende stroom	21 A
Aanloopstroom	138 A
Nominaal toerental	1450 rpm

Vermogensfactor	
1/1 Load	0,82
3/4 Load	0,76
1/2 Load	0,65
Motor efficiency	
1/1 Load	82,4 %
3/4 Load	82,3 %
1/2 Load	79,8 %

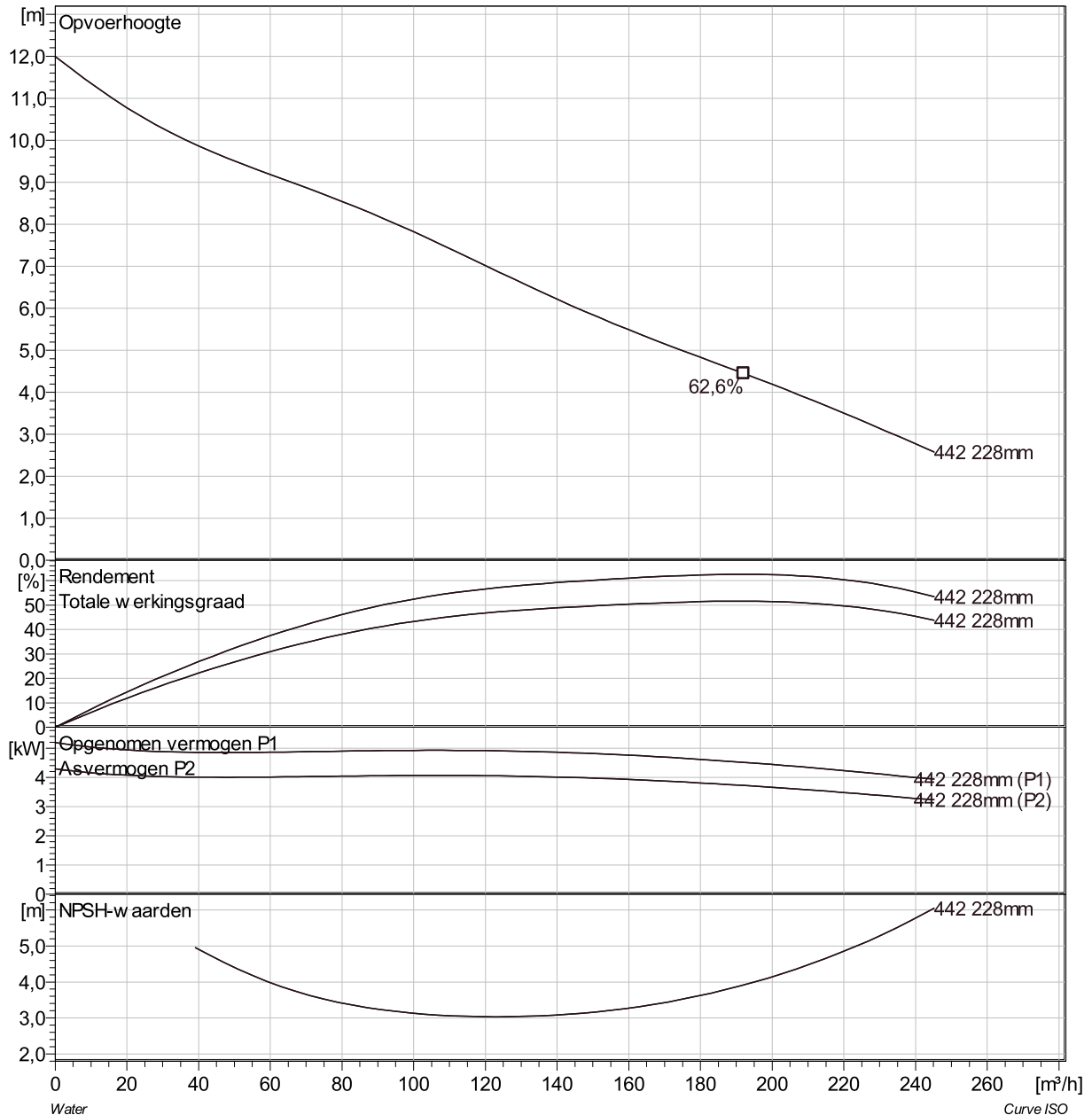

Project omschrijving	Projectnummer	Aangemaakt door:	Aangemaakt op 10/3/2018	Laatste wijziging
----------------------	---------------	------------------	----------------------------	-------------------

CS 3127 LT 3~ 442 VFD Analysis

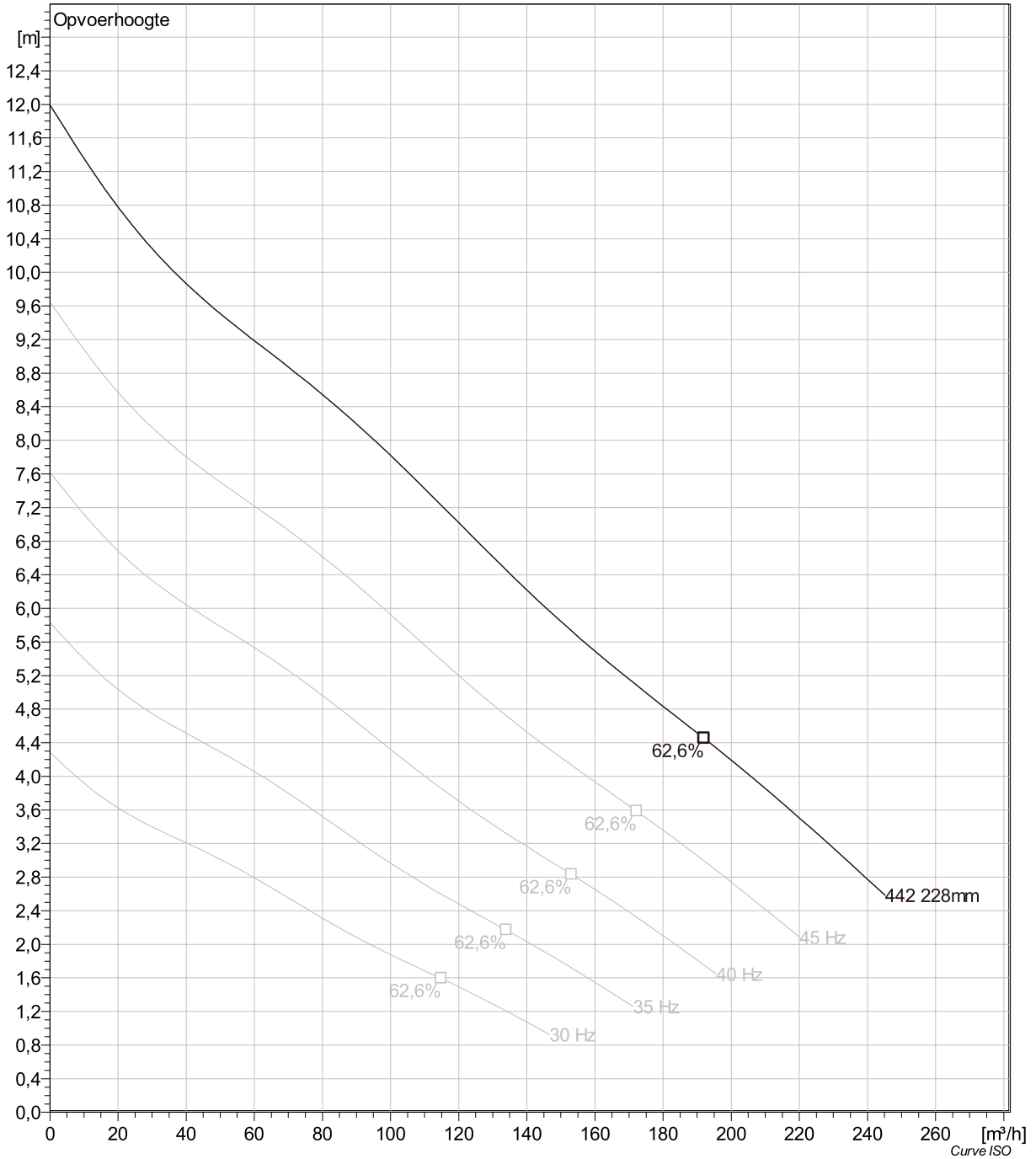

Project omschrijving	Projectnummer	Aangemaakt door:	Aangemaakt op 10/3/2018	Laatste wijziging
----------------------	---------------	------------------	-----------------------------------	-------------------

CS 3127 LT 3~ 442 Dimensional drawing

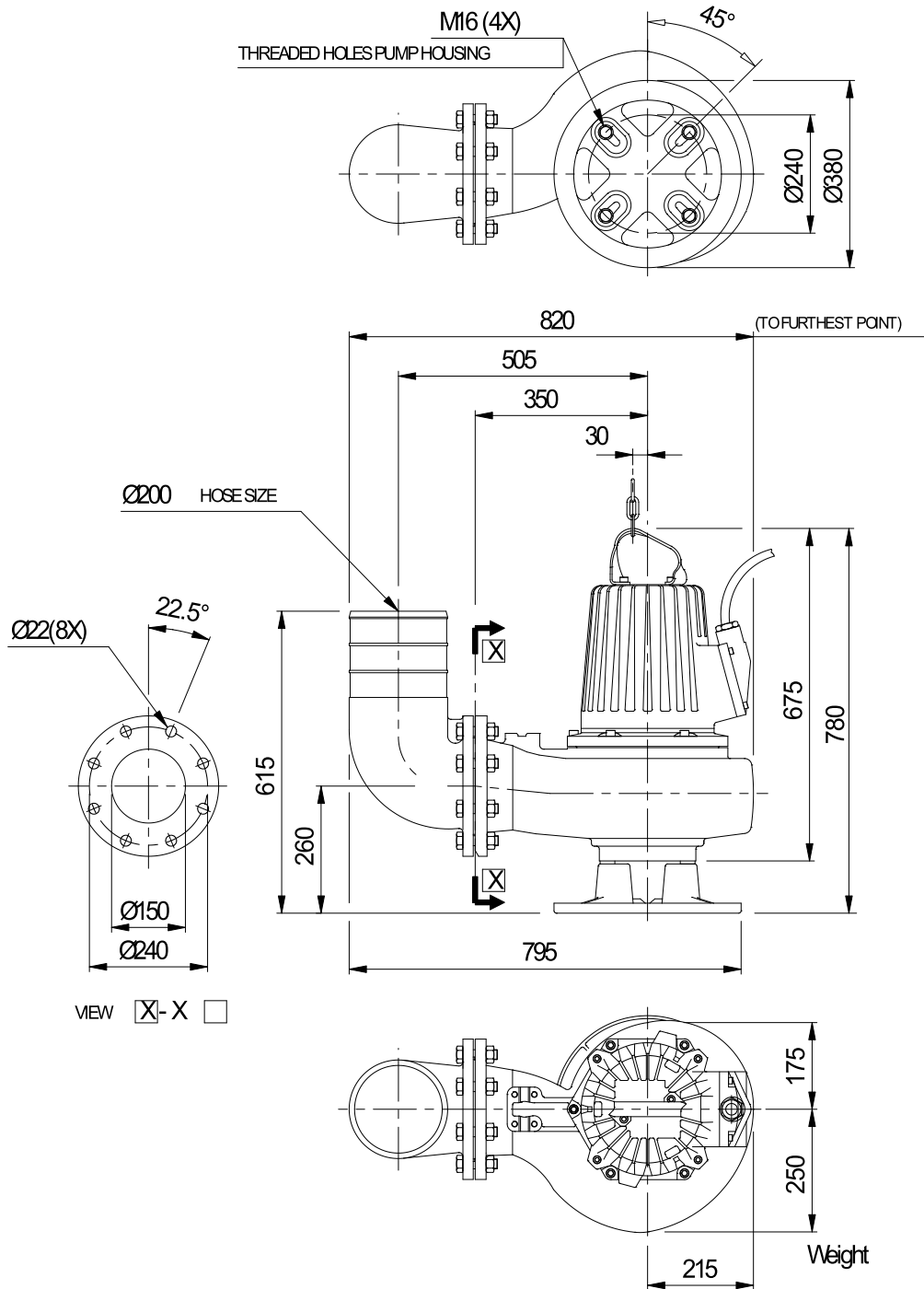

Dimensional dwg
CS3127LT

Project omschrijving	Projectnummer	Aangemaakt door:	Aangemaakt op 10/3/2018	Laatste wijziging
----------------------	---------------	------------------	----------------------------	-------------------