

CS 3201 HT 3~ 452

Technische specificaties

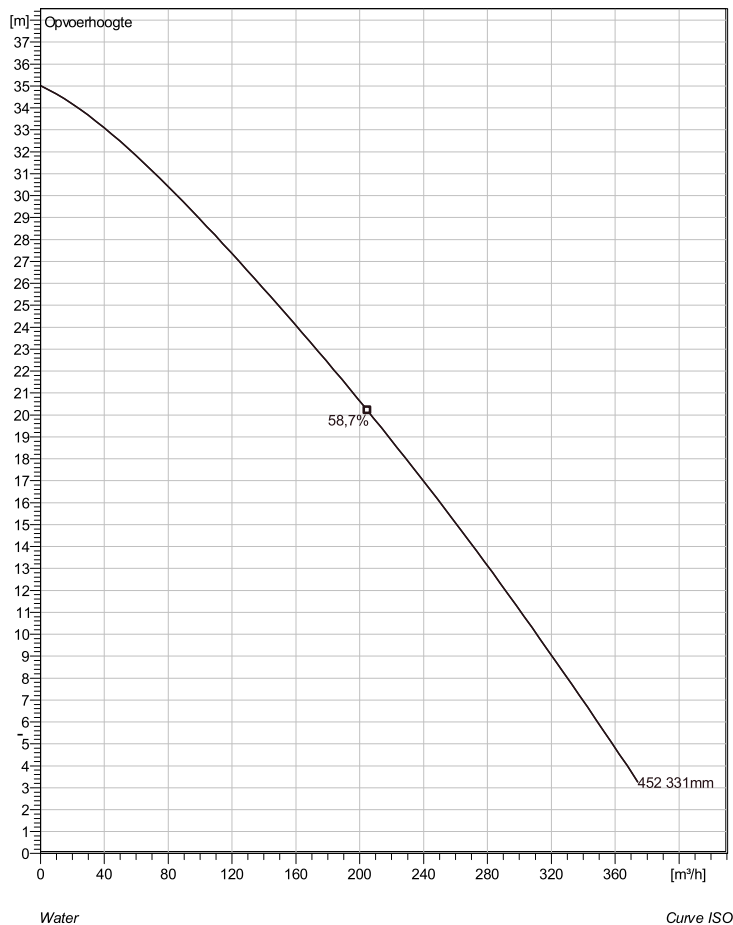

Note: Picture might not correspond to the current configuration.

General

Dompelbare pompen voorzien van één of meerkanaalwaaier met grote doorlaat. Geschikt voor afvalwater met grotere delen zoals rioolwater, regenwater en industrieel afvalwater. Materiaal gietijzer.

Impeller

Impeller material	Stainless steel
Persaansluiting	150 mm
Diameter aanzuigzijde	150 mm
Impeller diameter	331 mm
Aantal bladen	1
Throughlet diameter	77 mm

Motor

Motor #	C3201.280 27-20-4FA-W 22KW standaard
Stator variant	34
Frequentie	50 Hz
Nominale spanning	400 V
Aantal polen	4
Fasen	3~
Nominaal vermogen	22 kW
Toegekende stroom	42 A
Aanloopstroom	300 A
Nominaal toerental	1460 rpm
Vermogensfactor	
1/1 Load	0,86
3/4 Load	0,83
1/2 Load	0,74
Motor efficiency	
1/1 Load	87,0 %
3/4 Load	87,0 %
1/2 Load	85,5 %

Soort installatie: Semi permanent, Nat

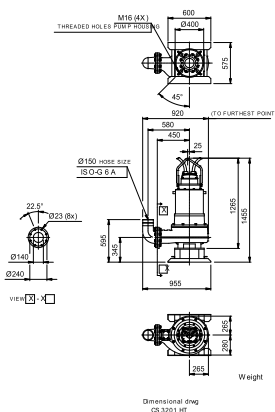

Project omschrijving	Projectnummer	Aangemaakt door:	Aangemaakt op 10/5/2018	Laatste wijziging
----------------------	---------------	------------------	----------------------------	-------------------

CS 3201 HT 3~ 452

Karakteristiek

Pomp

Persaansluiting	150 mm
Diameter aanzuigzijde	150 mm
Impeller diameter	331 mm
Aantal bladen	1
Throughlet diameter	77 mm

Motor

Motor #	C3201.280 27-20-4FA-W 22KW
Stator variant	34
Frequentie	50 Hz
Nominale spanning	400 V
Aantal polen	4
Fasen	3~
Nominaal vermogen	22 kW
Toegekende stroom	42 A
Aanloopstroom	300 A
Nominaal toerental	1460 rpm

Vermogensfactor	
1/1 Load	0,86
3/4 Load	0,83
1/2 Load	0,74
Motor efficiency	
1/1 Load	87,0 %
3/4 Load	87,0 %
1/2 Load	85,5 %

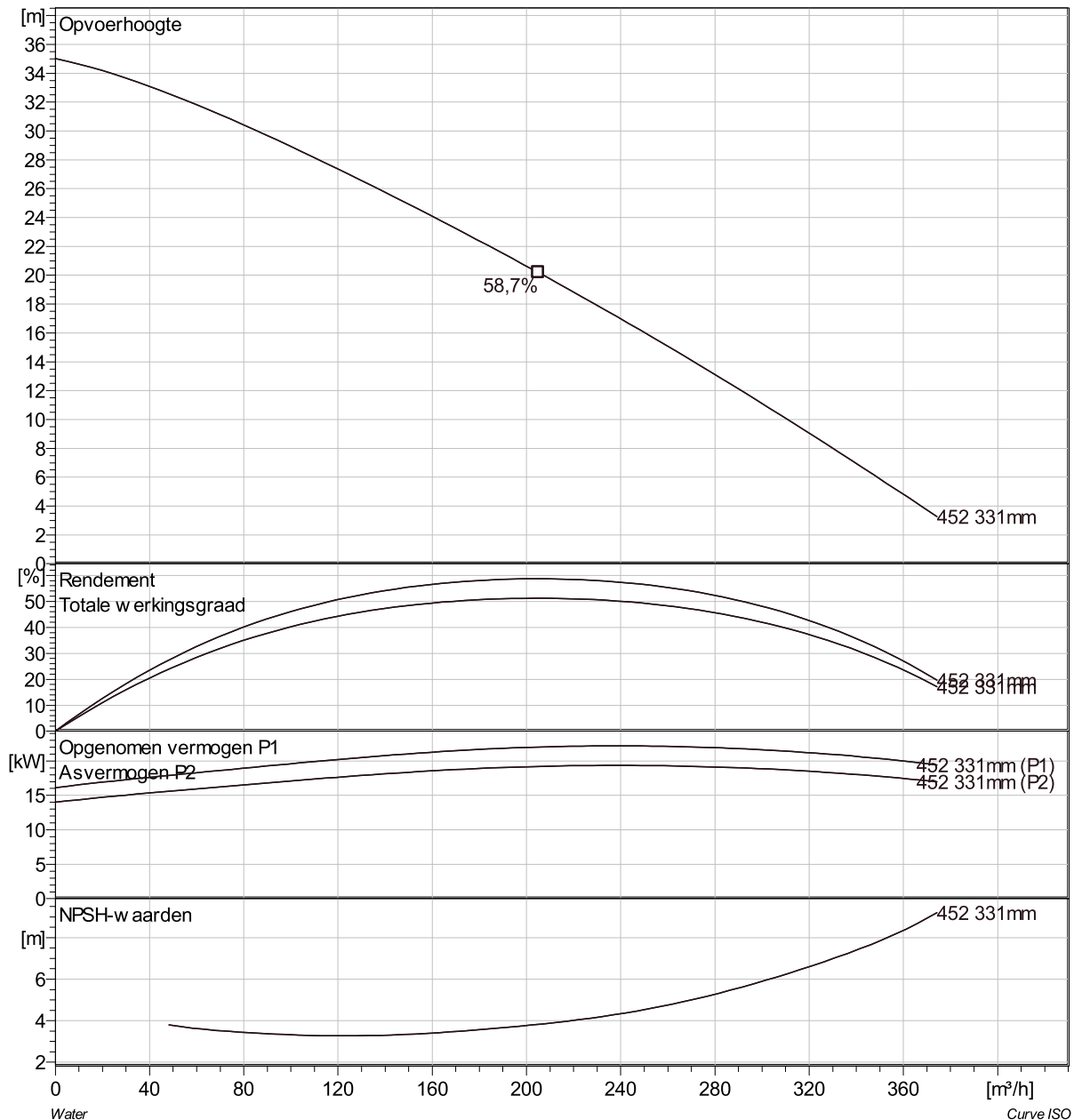

Project omschrijving	Projectnummer	Aangemaakt door:	Aangemaakt op 10/5/2018	Laatste wijziging
----------------------	---------------	------------------	----------------------------	-------------------

CS 3201 HT 3~ 452 VFD Analysis

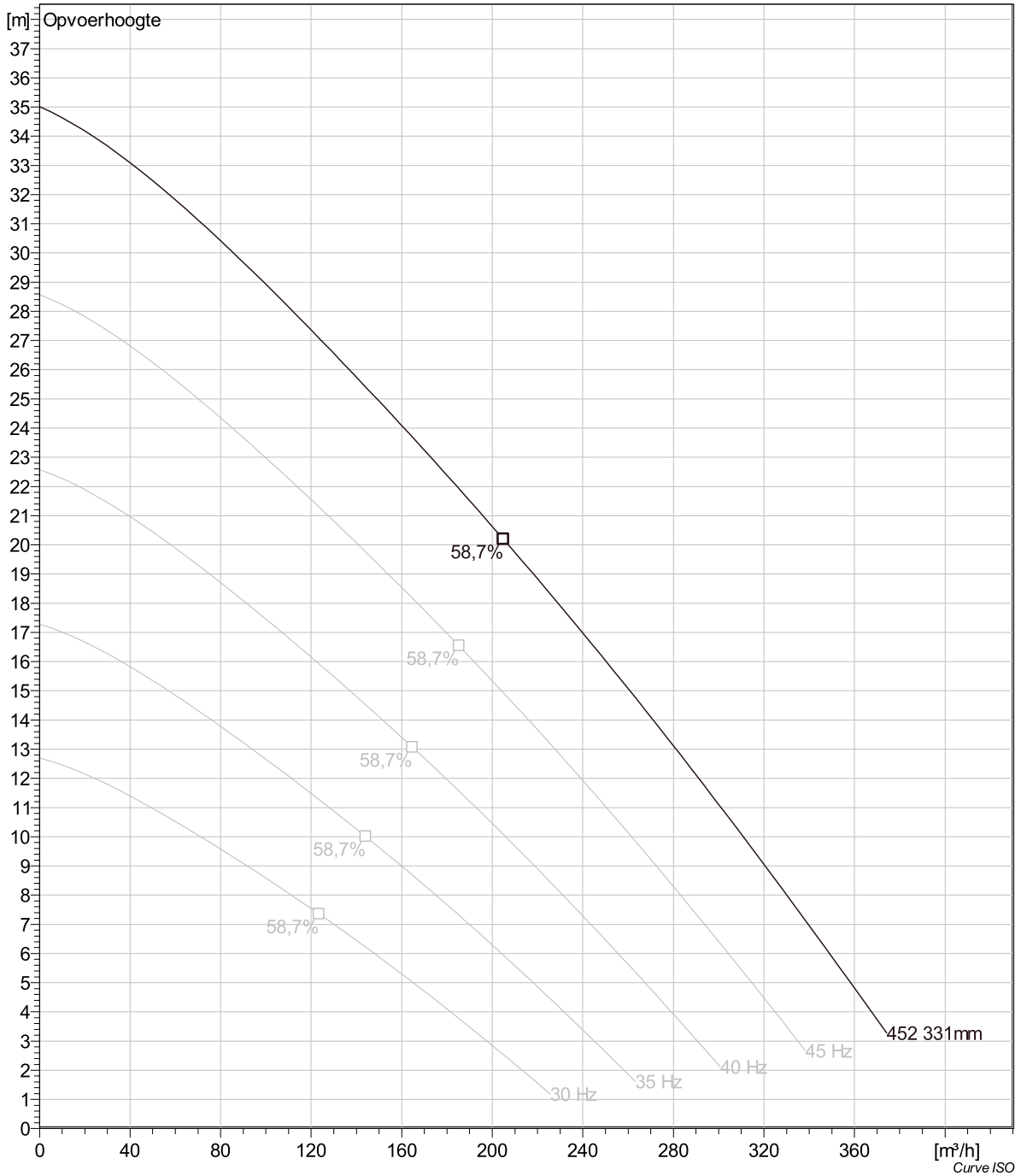

Project omschrijving	Projectnummer	Aangemaakt door:	Aangemaakt op 10/5/2018	Laatste wijziging
----------------------	---------------	------------------	----------------------------	-------------------

CS 3201 HT 3~ 452 Dimensional drawing

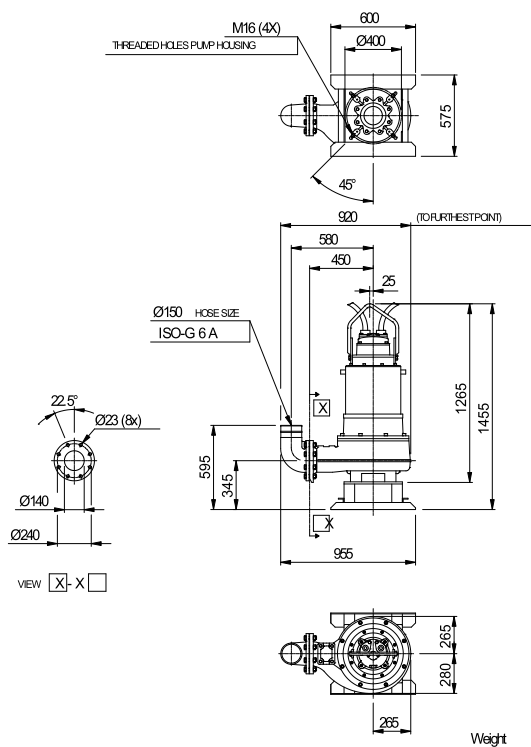

Dimensional drwg
CS3201 HT

Project omschrijving	Projectnummer	Aangemaakt door:	Aangemaakt op 10/5/2018	Laatste wijziging
----------------------	---------------	------------------	----------------------------	-------------------