

## CS 3201 HT 3~ 460 Technische specificaties

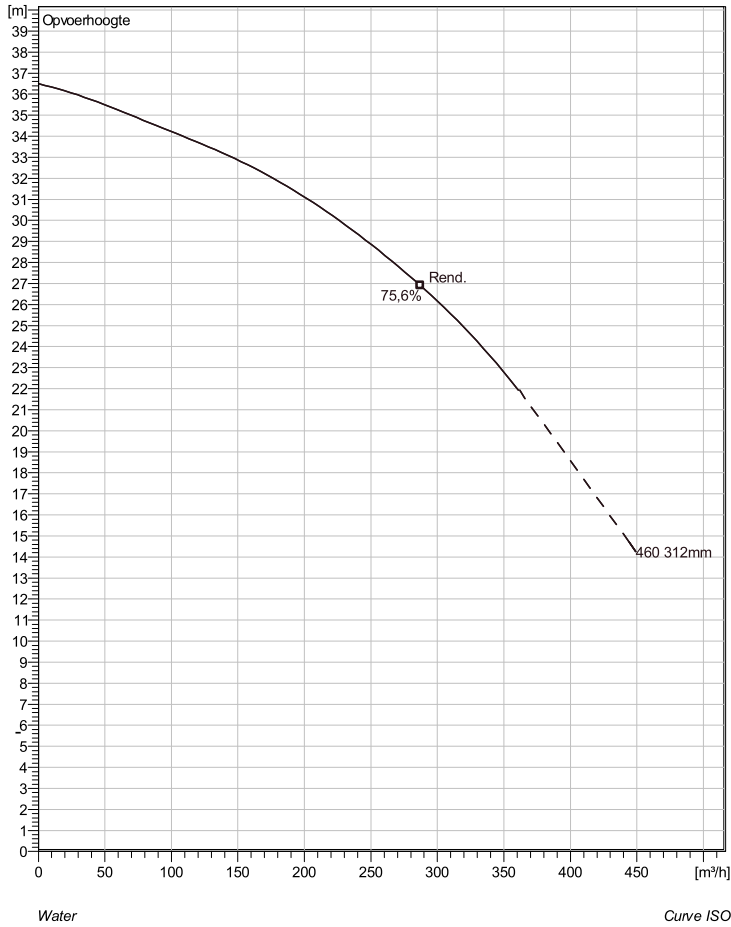

Note: Picture might not correspond to the current configuration.

### General

Dompelpbare pompen voorzien van één of meerkanaalwaaier met grote doorlaat. Geschikt voor afvalwater met grotere delen zoals rioolwater, regenwater en industrieel afvalwater. Materiaal gietijzer.

### Impeller

Impeller material	Stainless steel
Persaansluiting	150 mm
Diameter aanzuigzijde	150 mm
Impeller diameter	312 mm
Aantal bladen	3
Throughlet diameter	59 mm

### Motor

Motor #	C3201.280 27-26-4AA-W 30KW standaard
Stator variant	28
Frequentie	50 Hz
Nominale spanning	190 V
Aantal polen	4
Fasen	3~
Nominaal vermogen	30 kW
Toegekende stroom	124 A
Aanloopstroom	935 A
Nominaal toerental	1465 rpm
Vermogensfactor	
1/1 Load	0,84
3/4 Load	0,79
1/2 Load	0,68
Motor efficiency	
1/1 Load	87,5 %
3/4 Load	87,5 %
1/2 Load	85,5 %

Soort installatie: Semi permanent, Nat

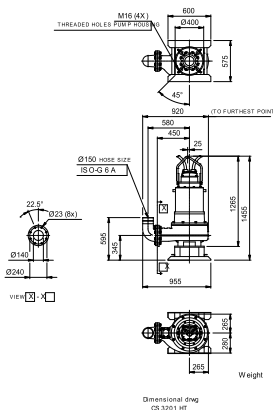

Project	Project ID	Created by	Created on 10/4/2018	Last update
---------	------------	------------	-------------------------	-------------

## CS 3201 HT 3~ 460

### Karakteristiek

#### Pomp

Persaansluiting	150 mm
Diameter aanzuigzijde	150 mm
Impeller diameter	312 mm
Aantal bladen	3
Throughlet diameter	59 mm

#### Motor

Motor #	C3201.280 27-26-4AA-W 30KW
Stator variant	28
Frequentie	50 Hz
Nominale spanning	190 V
Aantal polen	4
Fasen	3~
Nominaal vermogen	30 kW
Toegekende stroom	124 A
Aanloopstroom	935 A
Nominaal toerental	1465 rpm

Vermogensfactor	
1/1 Load	0,84
3/4 Load	0,79
1/2 Load	0,68
Motor efficiency	
1/1 Load	87,5 %
3/4 Load	87,5 %
1/2 Load	85,5 %

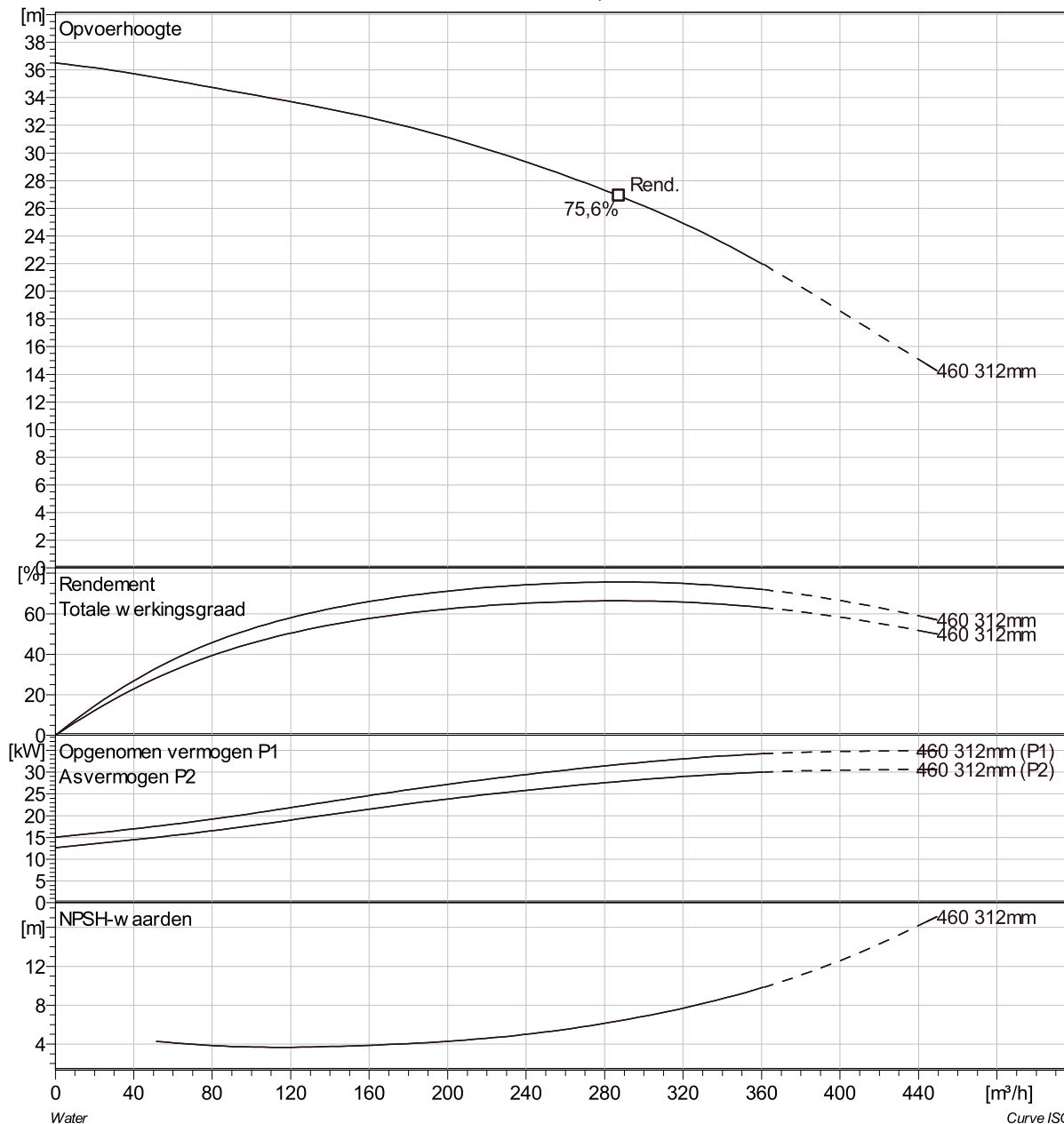

Project	Project ID	Created by	Created on 10/4/2018	Last update
---------	------------	------------	-------------------------	-------------

## CS 3201 HT 3~ 460 VFD Analysis

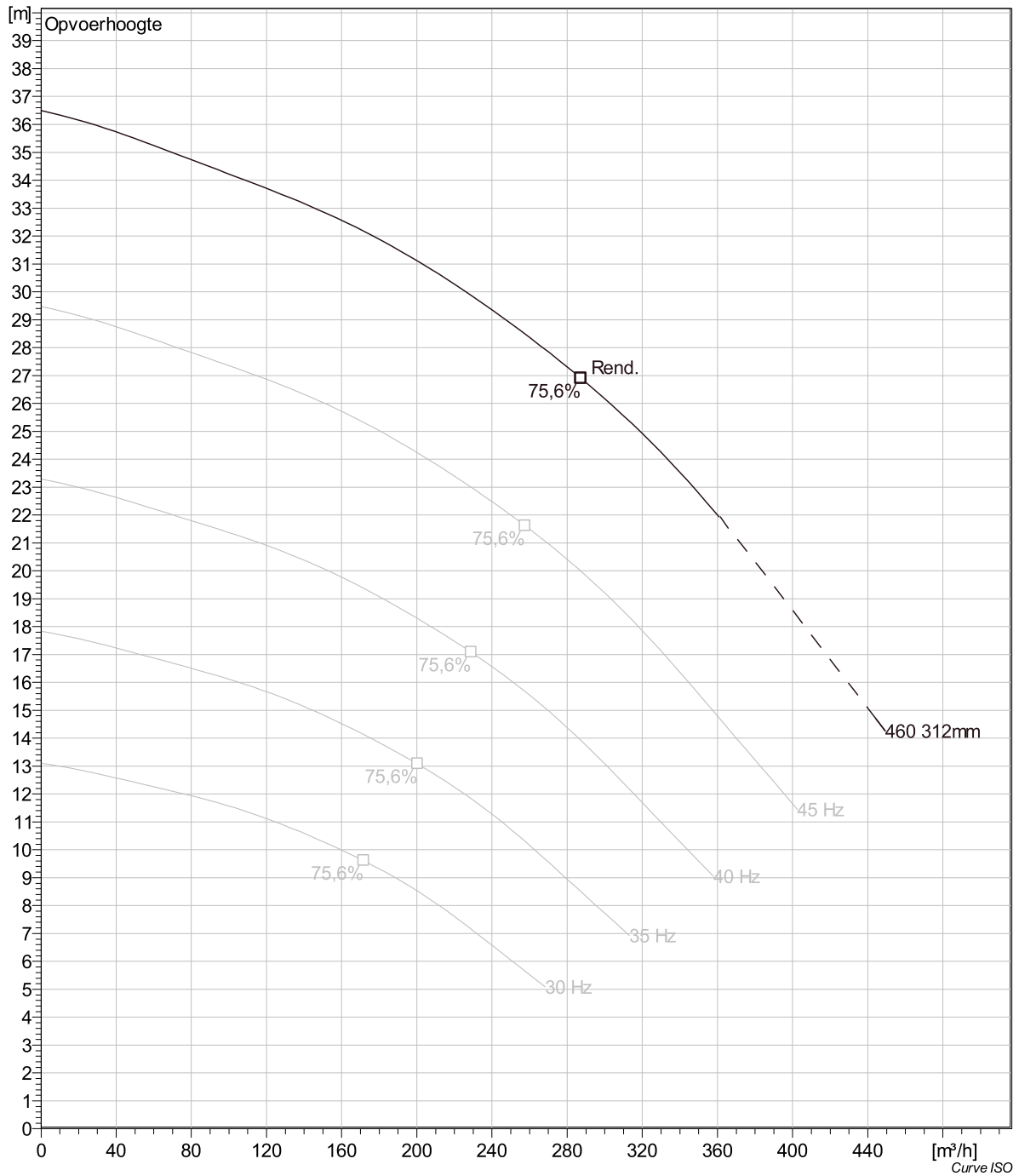

Project	Project ID	Created by	Created on	Last update
			10/4/2018	

## CS 3201 HT 3~ 460 Dimensional drawing

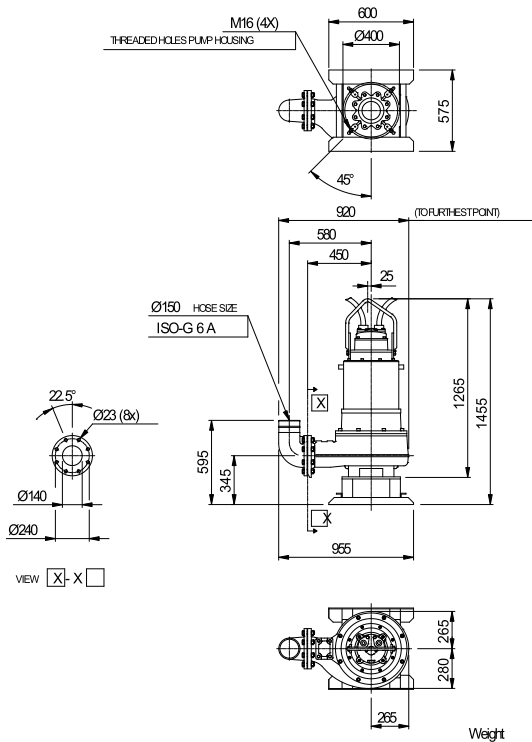

Dimensional drwg  
CS3201 HT

Project	Project ID	Created by	Created on	Last update
			10/4/2018	