

NP 3102 MT 3~ Adaptive 460

Technische specificaties

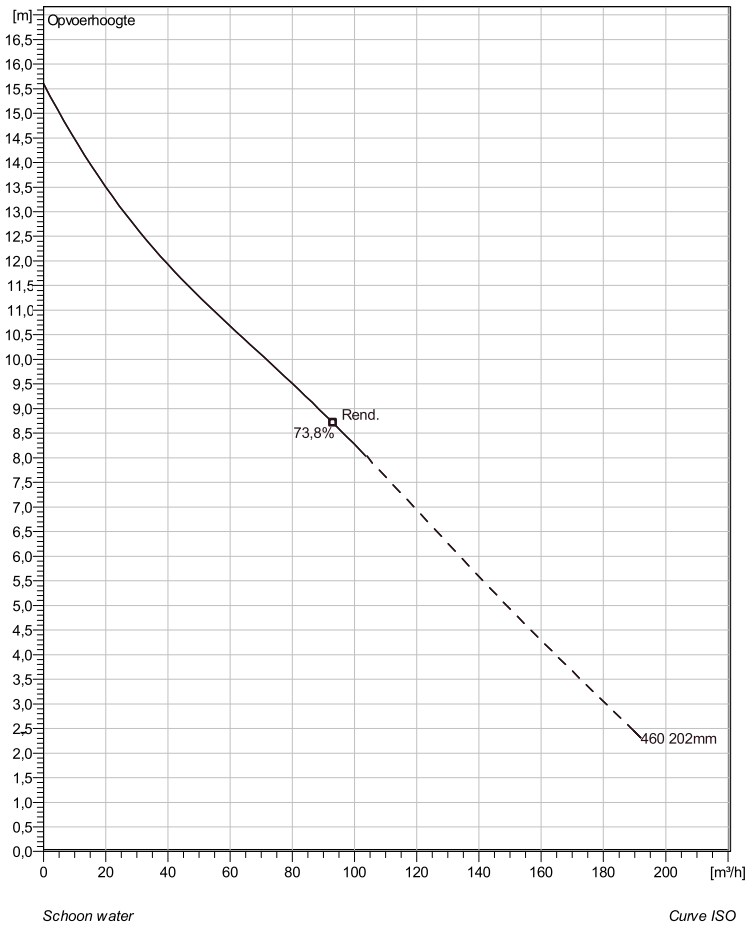

Note: Picture might not correspond to the current configuration.

General

Dompelbare pompen voorzien van een verstopingsongevoeilige N-waaiër. Geschikt voor afvalwater met grotere delen zoals rioolwater, regenwater en industriële afvalwater. Materiaal gietijzer.

Impeller

Impeller material	Grey cast iron
Persaansluiting	100 mm
Diameter aanzuigzijde	100 mm
Impeller diameter	202 mm
Aantal bladen	2

Motor

Motor #	N3102.160 18-11-4AL-W 3.1KW standaard
Stator variant	66
Frequentie	50 Hz
Nominale spanning	190 V
Aantal polen	4
Fasen	3~
Nominaal vermogen	3,1 kW
Toegekende stroom	13 A
Aanloopstroom	71 A
Nominaal toerental	1440 rpm
Vermogensfactor	
1/1 Load	0,84
3/4 Load	0,79
1/2 Load	0,68
Motor efficiency	
1/1 Load	83,5 %
3/4 Load	85,0 %
1/2 Load	84,0 %

Soort installatie: Semi Permanent, Nat

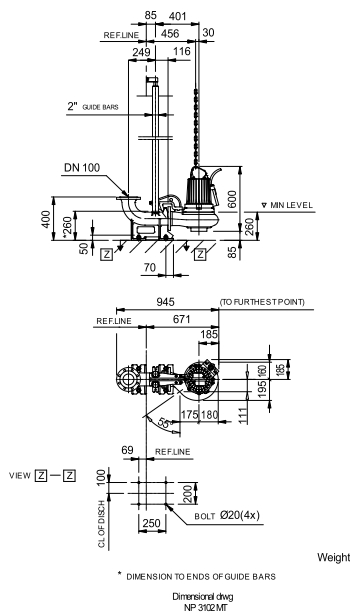

Project	Project ID	Created by	Created on 9/27/2018	Last update
---------	------------	------------	-------------------------	-------------

NP 3102 MT 3~ Adaptive 460

Karakteristiek

Pomp

Persaansluiting	100 mm
Diameter aanzuigzijde	100 mm
Impeller diameter	202 mm
Aantal bladen	2

Motor

Motor #	N3102.160 18-11-4AL-W 3.1KW
Stator variant	66
Frequentie	50 Hz
Nominale spanning	190 V
Aantal polen	4
Fasen	3~
Nominaal vermogen	3,1 kW
Toegekende stroom	13 A
Aanloopstroom	71 A
Nominaal toerental	1440 rpm

Vermogensfactor	
1/1 Load	0,84
3/4 Load	0,79
1/2 Load	0,68
Motor efficiency	
1/1 Load	83,5 %
3/4 Load	85,0 %
1/2 Load	84,0 %

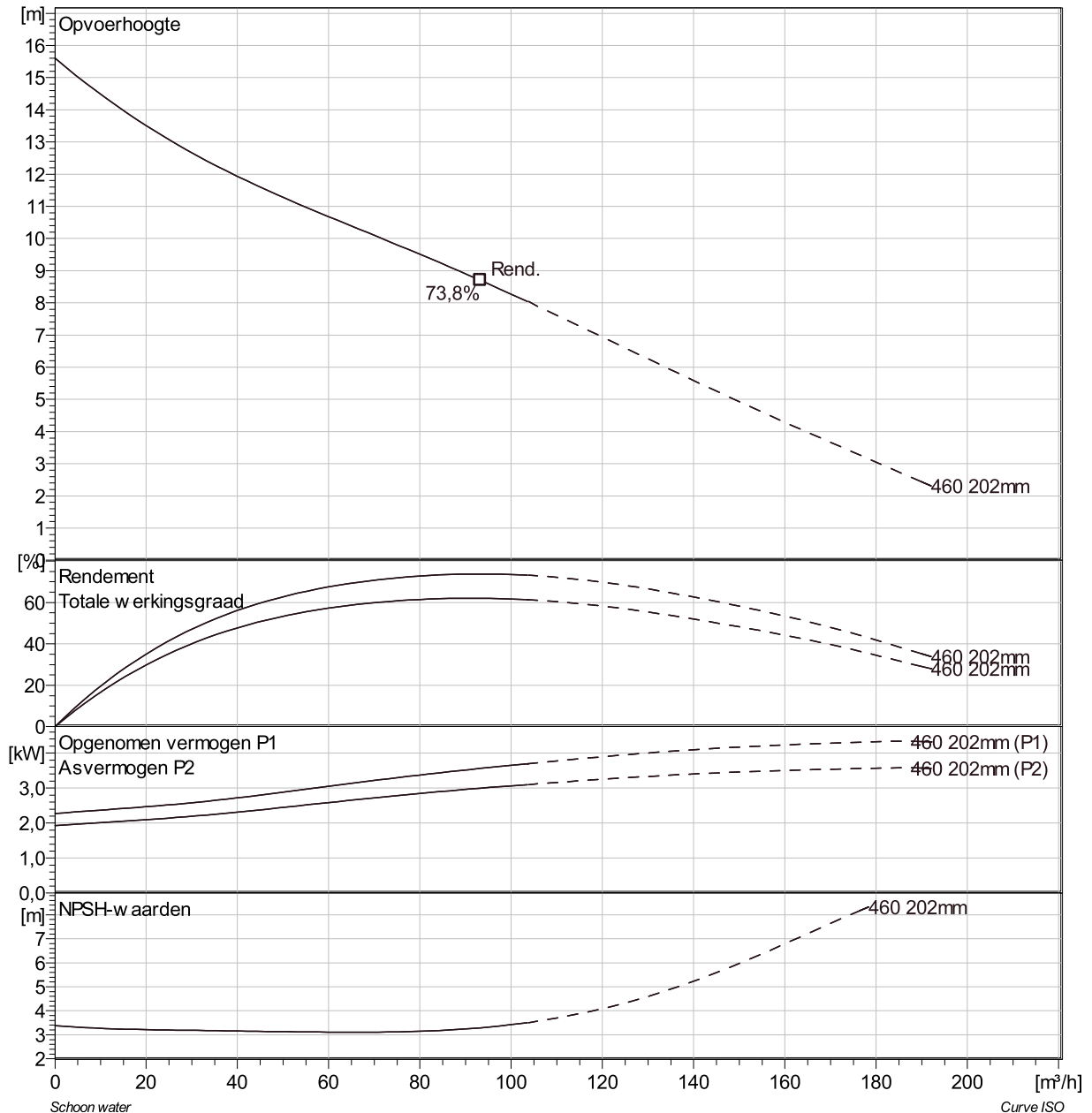

Project	Project ID	Created by	Created on 9/27/2018	Last update
---------	------------	------------	-------------------------	-------------

NP 3102 MT 3~ Adaptive 460 VFD Analysis

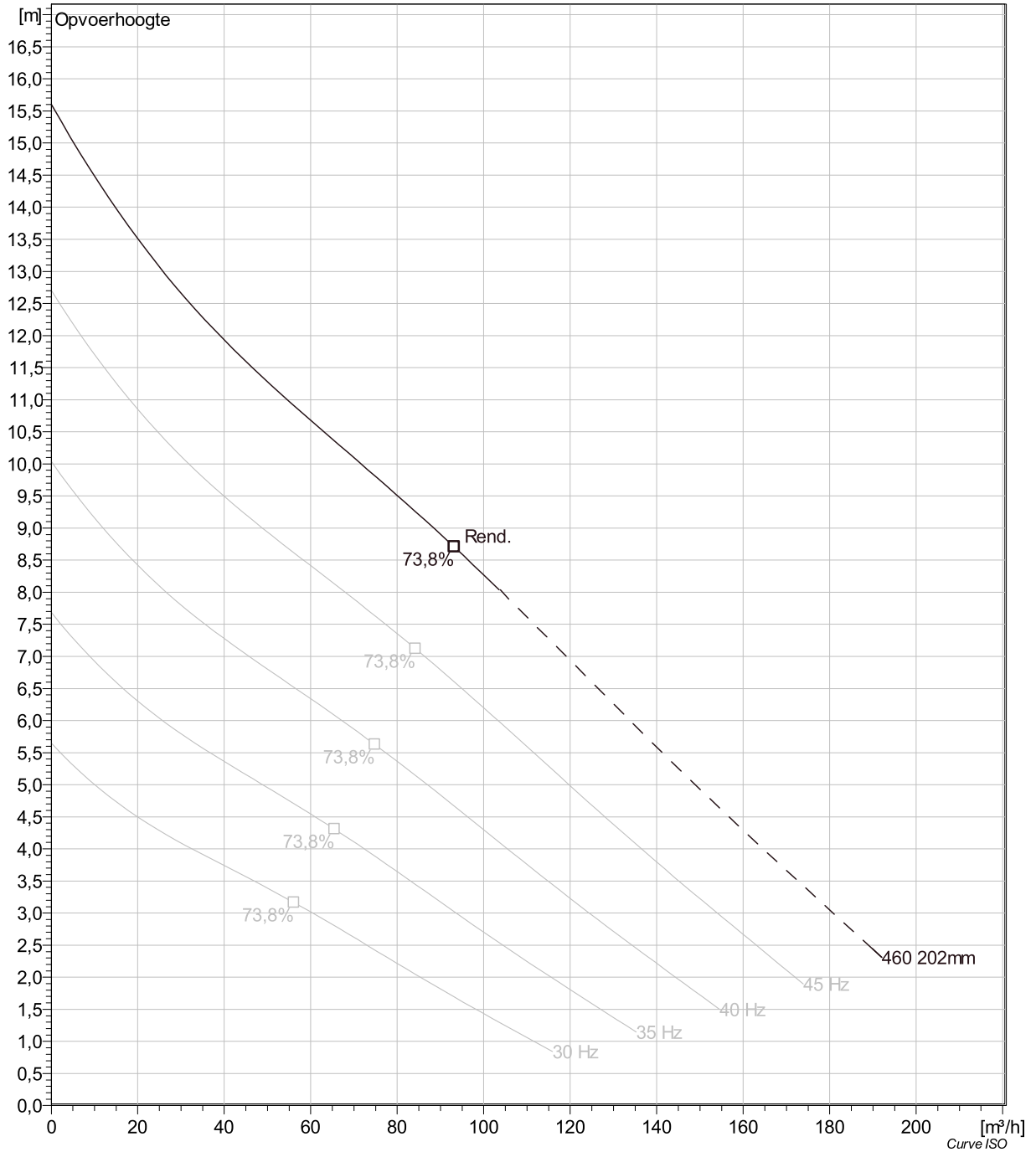

Project	Project ID	Created by	Created on	Last update
			9/27/2018	

NP 3102 MT 3~ Adaptive 460

Dimensional drawing

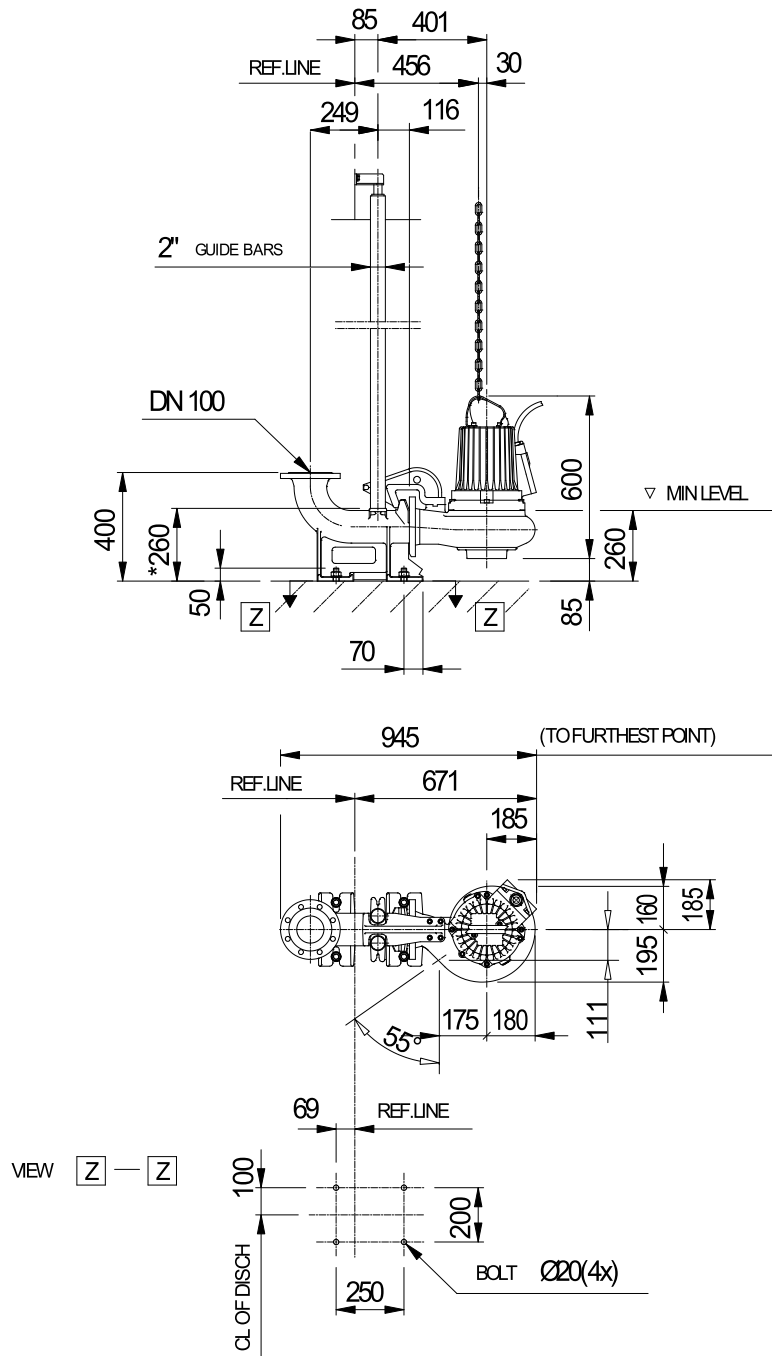

Weight

* DIMENSION TO ENDS OF GUIDE BARS

Dimensional dwg
NP3102MT

Project	Project ID	Created by	Created on	Last update
			9/27/2018	