

## NS 3102 LT 3~ Adaptive 421 Technische specificaties

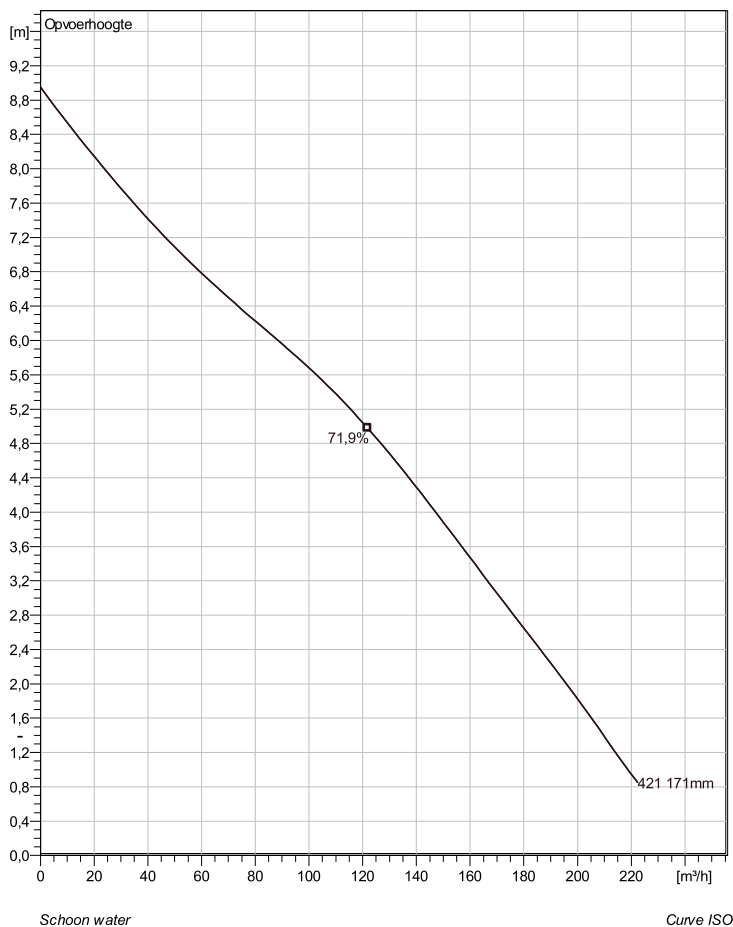

Note: Picture might not correspond to the current configuration.

### General

Dompelbare pompen voorzien van een verstopingsgevoelige N-waaiër. Geschikt voor afvalwater met grotere delen zoals rioolwater, regenwater en industriële afvalwater. Materiaal gietijzer.

### Impeller

Impeller material	Grey cast iron
Persaansluiting	150 mm
Diameter aanzuigzijde	150 mm
Impeller diameter	171 mm
Aantal bladen	2

### Soort installatie: Semi permanent, Nat

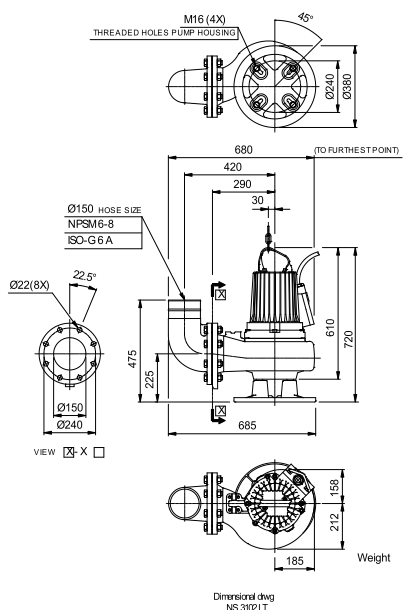

### Motor

Motor #	N3102.160 18-11-4AL-W 3.1KW standaard
Stator variant	66
Frequentie	50 Hz
Nominale spanning	190 V
Aantal polen	4
Fasen	3~
Nominaal vermogen	3,1 kW
Toegekende stroom	13 A
Aanloopstroom	71 A
Nominaal toerental	1440 rpm
Vermogensfactor	
1/1 Load	0,84
3/4 Load	0,79
1/2 Load	0,68
Motor efficiency	
1/1 Load	83,5 %
3/4 Load	85,0 %
1/2 Load	84,0 %

Project	Project ID	Created by	Created on 10/5/2018	Last update
---------	------------	------------	-------------------------	-------------

## NS 3102 LT 3~ Adaptive 421

### Karakteristiek

#### Pomp

Persaansluiting	150 mm
Diameter aanzuigzijde	150 mm
Impeller diameter	171 mm
Aantal bladen	2

#### Motor

Motor #	N3102.160 18-11-4AL-W 3.1KW
Stator variant	66
Frequentie	50 Hz
Nominale spanning	190 V
Aantal polen	4
Fasen	3~
Nominaal vermogen	3,1 kW
Toegekende stroom	13 A
Aanloopstroom	71 A
Nominaal toerental	1440 rpm

Vermogensfactor	
1/1 Load	0,84
3/4 Load	0,79
1/2 Load	0,68
Motor efficiency	
1/1 Load	83,5 %
3/4 Load	85,0 %
1/2 Load	84,0 %

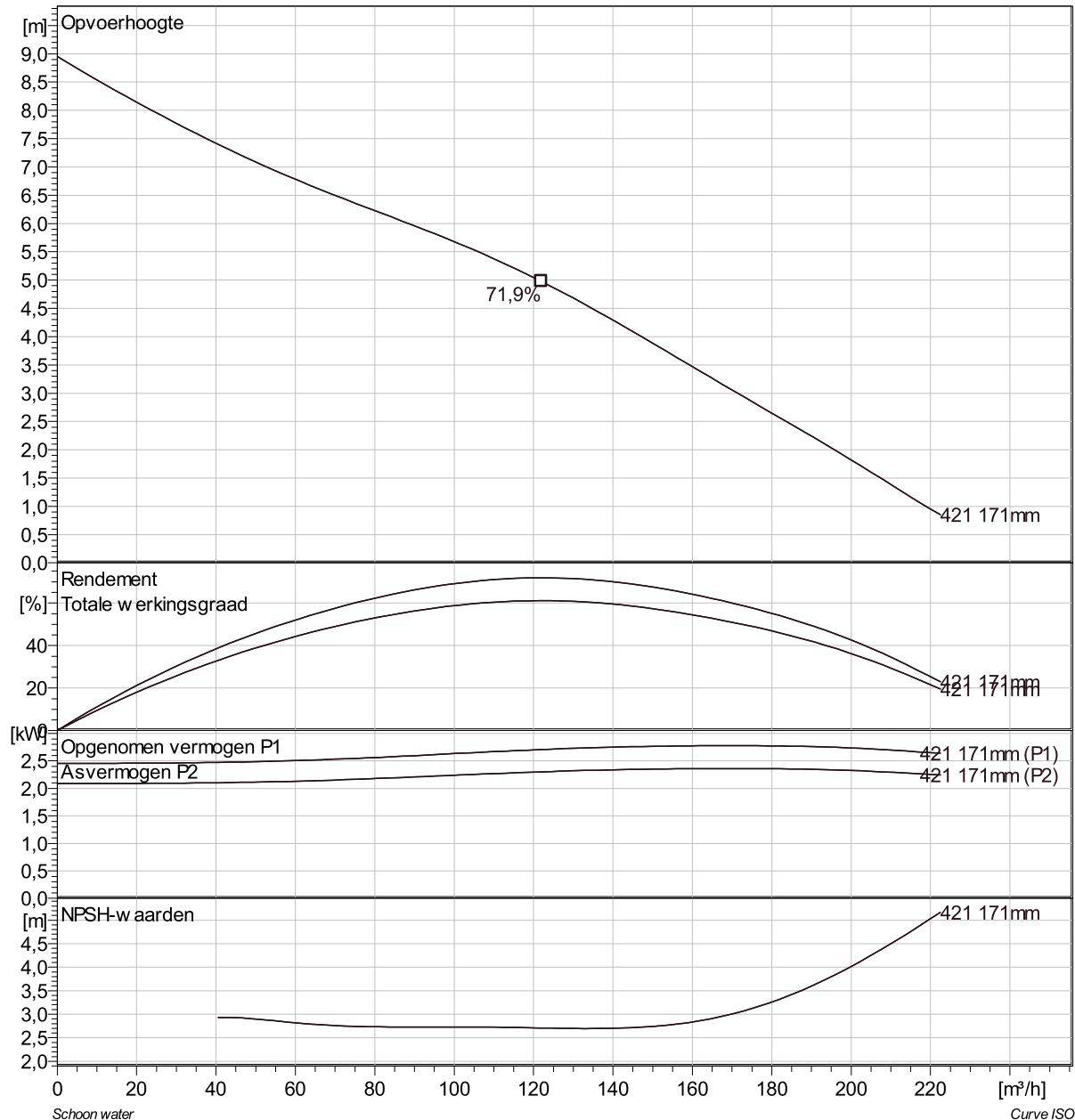

Project	Project ID	Created by	Created on 10/5/2018	Last update
---------	------------	------------	-------------------------	-------------

## NS 3102 LT 3~ Adaptive 421 VFD Analysis

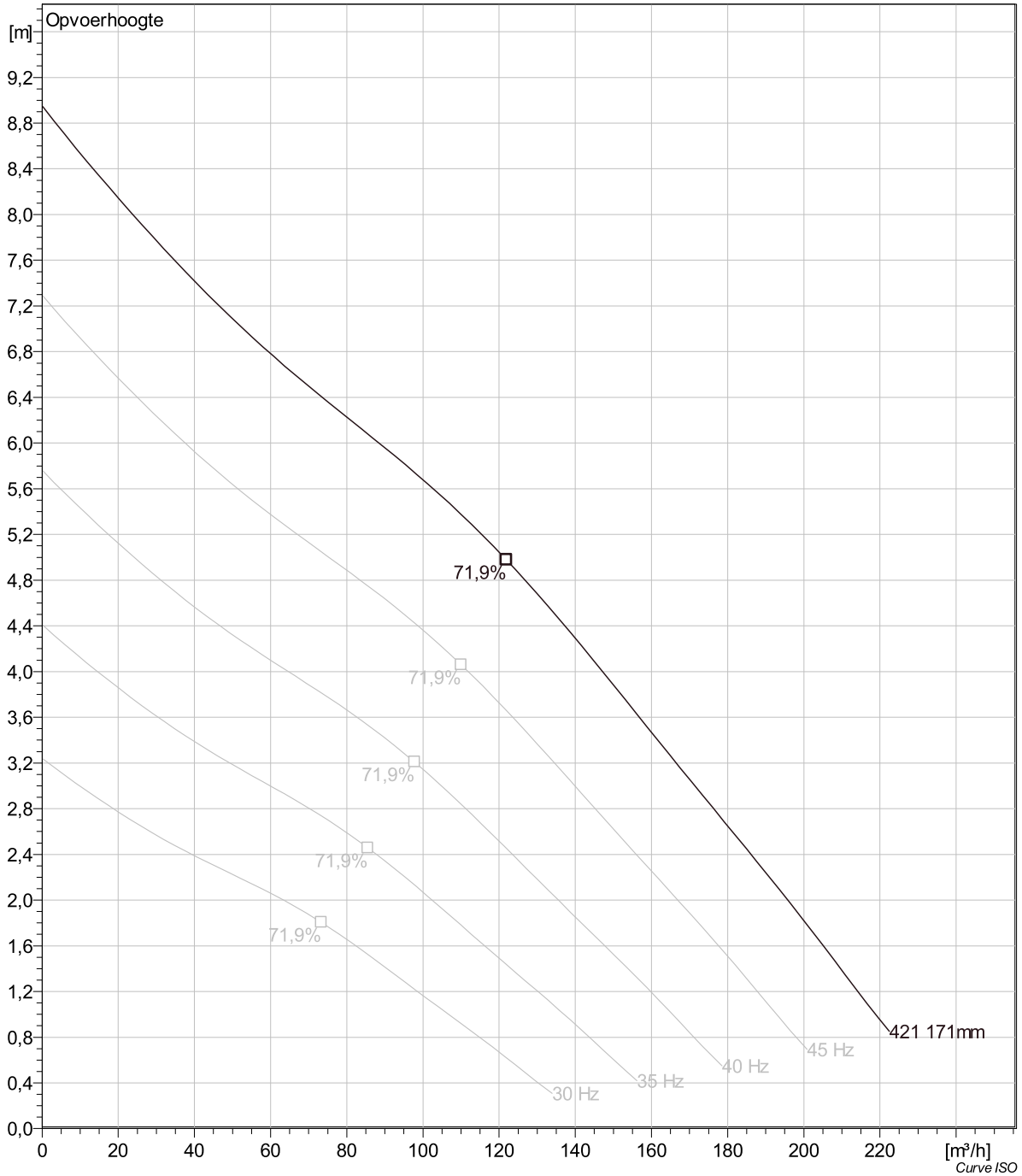

Project	Project ID	Created by	Created on	Last update
			10/5/2018	

## NS 3102 LT 3~ Adaptive 421 Dimensional drawing

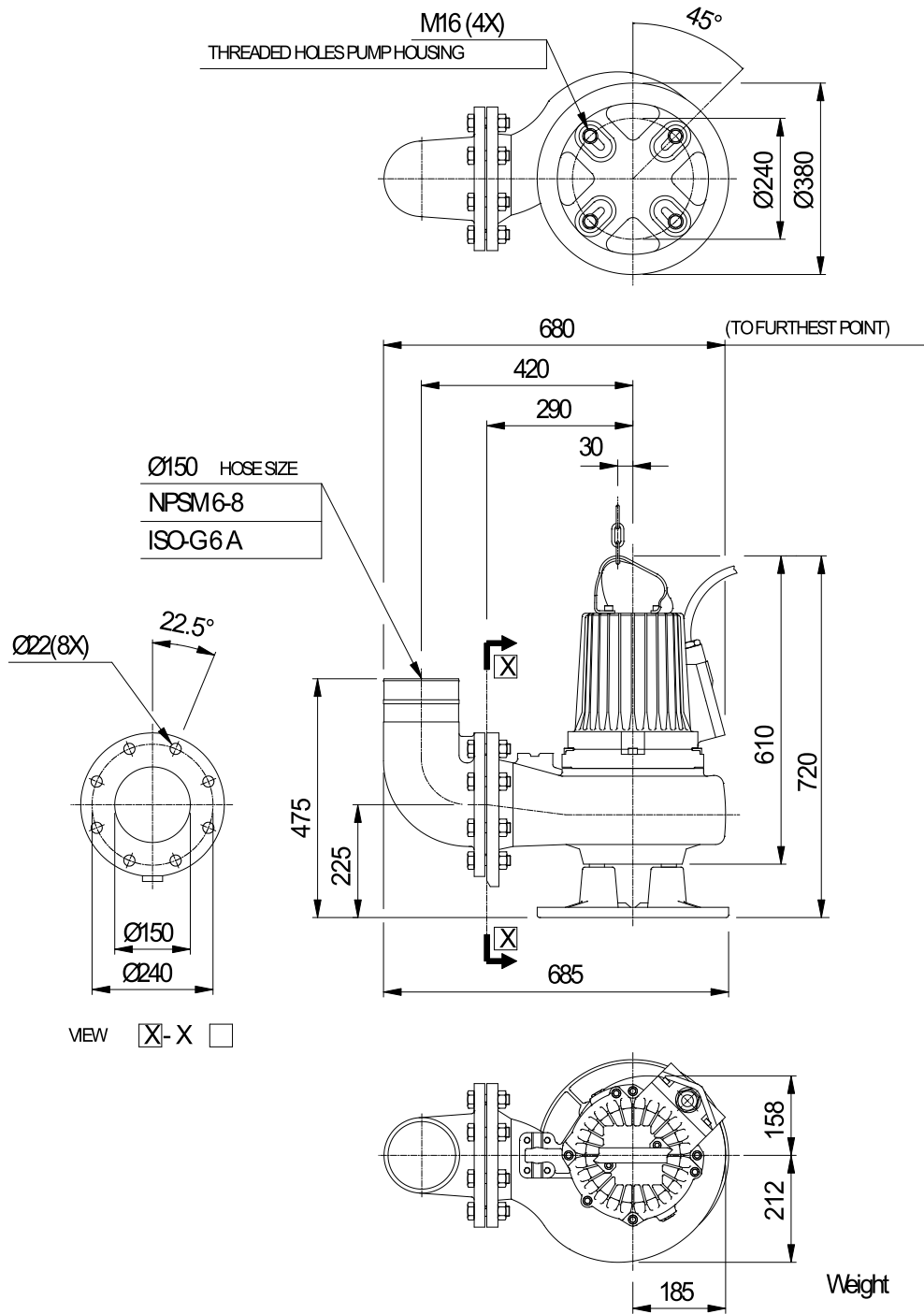

Dimensional dwg  
NS3102LT

Project	Project ID	Created by	Created on	Last update
			10/5/2018	