

## NP 3127 HT 3~ Adaptive 489

### Technische specificaties

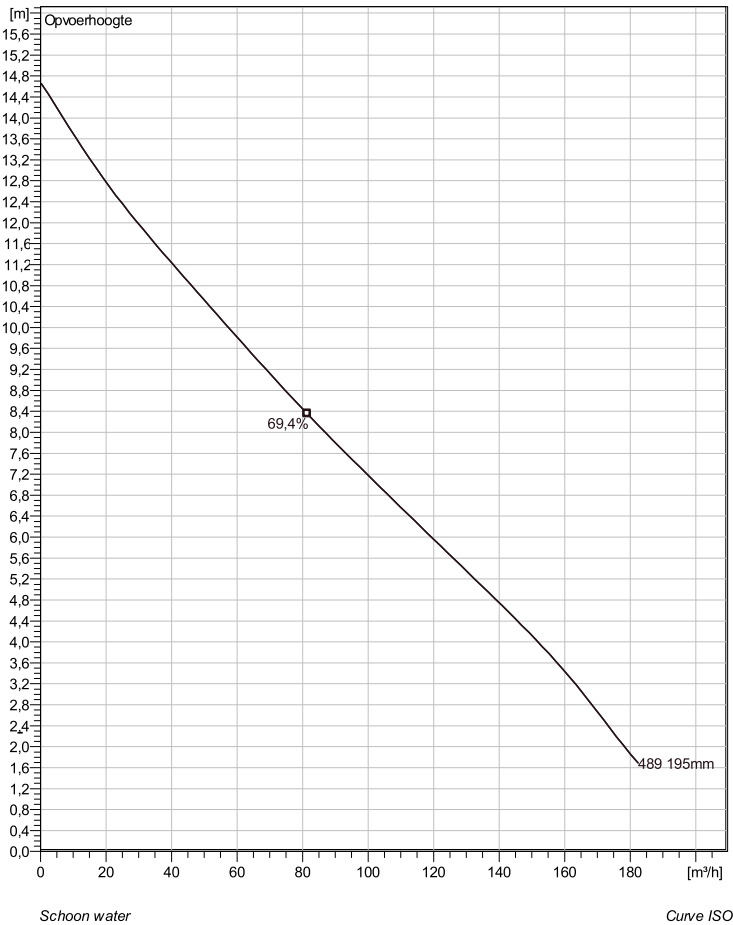

Note: Picture might not correspond to the current configuration.

#### General

Dompelbare pompen voorzien van verstopponsgevoelige N-waaiers. Geschikt voor afvalwater met grotere delen zoals rioolwater, regenwater en industriële afvalwater. Materiaal gietijzer.

#### Impeller

Impeller material	Grey cast iron
Persaansluiting	100 mm
Diameter aanzuigzijde	100 mm
Impeller diameter	195 mm
Aantal bladen	2

#### Motor

Motor #	N3127.161 21-10-4AL-W 4.7KW standaard
Stator variant	2
Frequentie	50 Hz
Nominale spanning	400 V
Aantal polen	4
Fasen	3~
Nominaal vermogen	4,7 kW
Toegekende stroom	9,6 A
Aanloopstroom	58 A
Nominaal toerental	1445 rpm
Vermogensfactor	
1/1 Load	0,85
3/4 Load	0,81
1/2 Load	0,71
Motor efficiency	
1/1 Load	83,0 %
3/4 Load	83,8 %
1/2 Load	82,4 %

#### Soort installatie: Semi Permanent, Nat

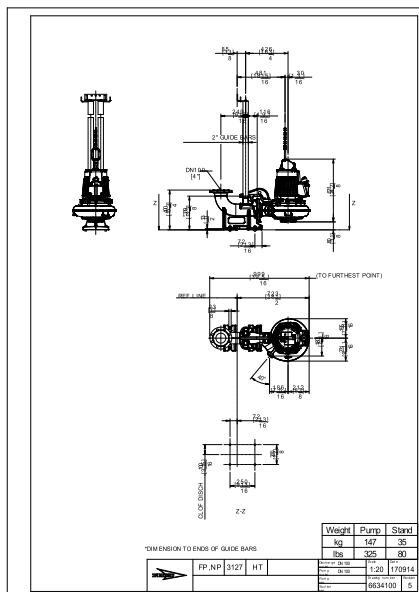

Project omschrijving	Projectnummer	Aangemaakt door:	Aangemaakt op 9/27/2018	Laatste wijziging
----------------------	---------------	------------------	----------------------------	-------------------

## NP 3127 HT 3~ Adaptive 489

### Karakteristiek

#### Pomp

Persaansluiting	100 mm
Diameter aanzuigzijde	100 mm
Impeller diameter	195 mm
Aantal bladen	2

#### Motor

Motor #	N3127.161 21-10-4AL-W 4.7KW
Stator variant	2
Frequentie	50 Hz
Nominale spanning	400 V
Aantal polen	4
Fasen	3~
Nominaal vermogen	4,7 kW
Toegekende stroom	9,6 A
Aanloopstroom	58 A
Nominaal toerental	1445 rpm

Vermogensfactor	
1/1 Load	0,85
3/4 Load	0,81
1/2 Load	0,71
Motor efficiency	
1/1 Load	83,0 %
3/4 Load	83,8 %
1/2 Load	82,4 %

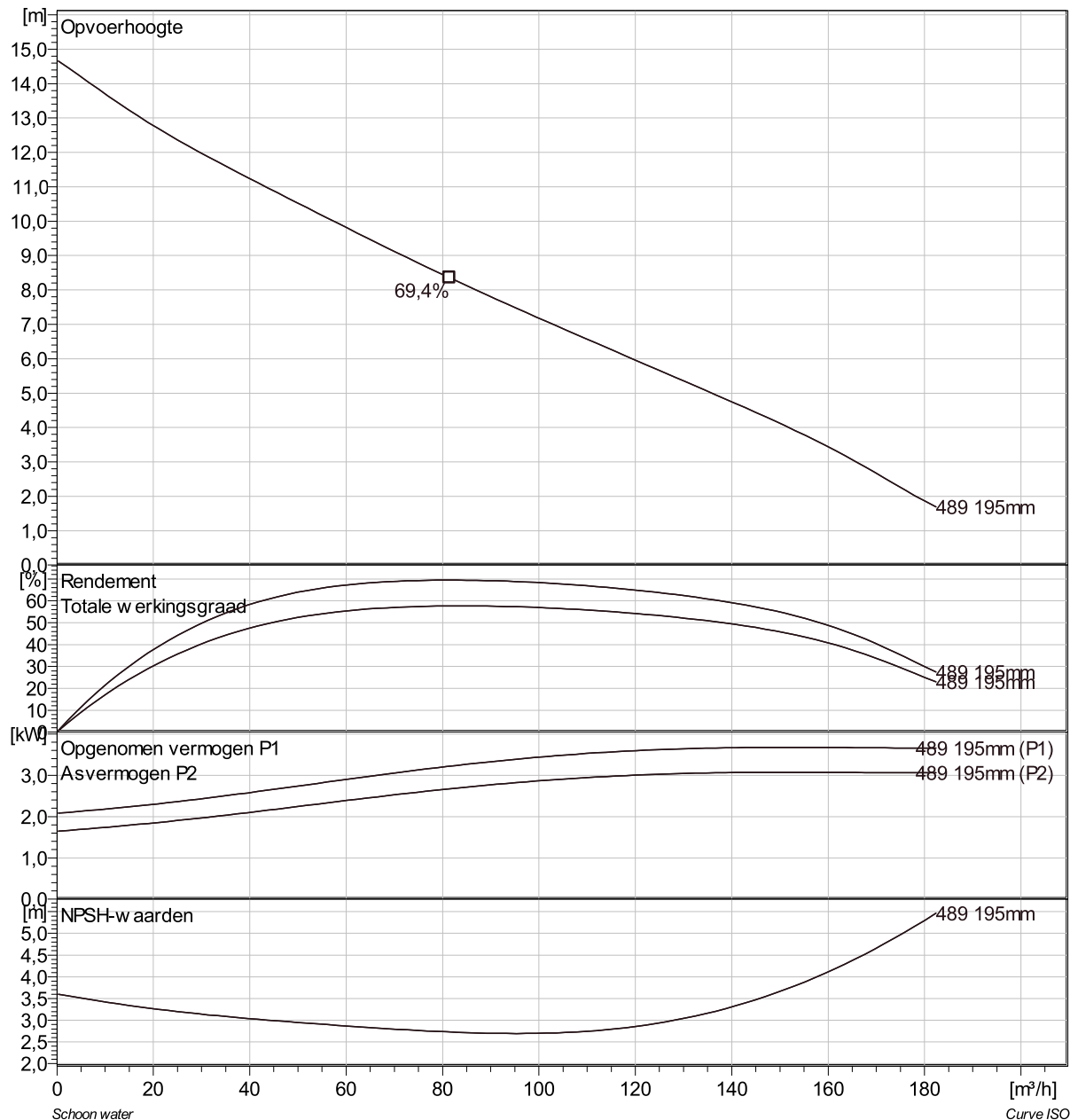

Project omschrijving	Projectnummer	Aangemaakt door:	Aangemaakt op 9/27/2018	Laatste wijziging
----------------------	---------------	------------------	----------------------------	-------------------

## NP 3127 HT 3~ Adaptive 489 VFD Analysis

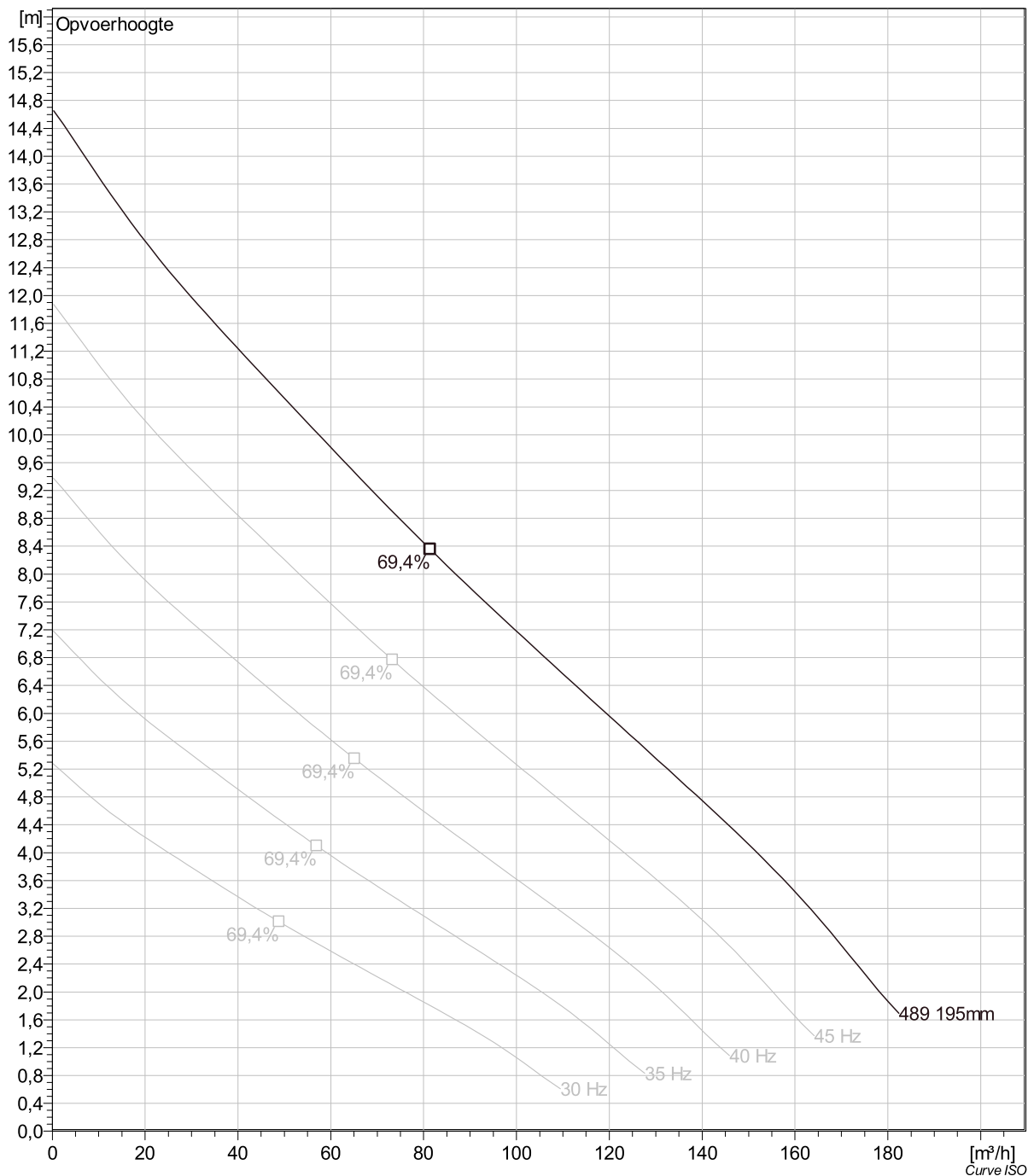

Project omschrijving	Projectnummer	Aangemaakt door:	Aangemaakt op 9/27/2018	Laatste wijziging
----------------------	---------------	------------------	----------------------------	-------------------

## NP 3127 HT 3~ Adaptive 489 Dimensional drawing

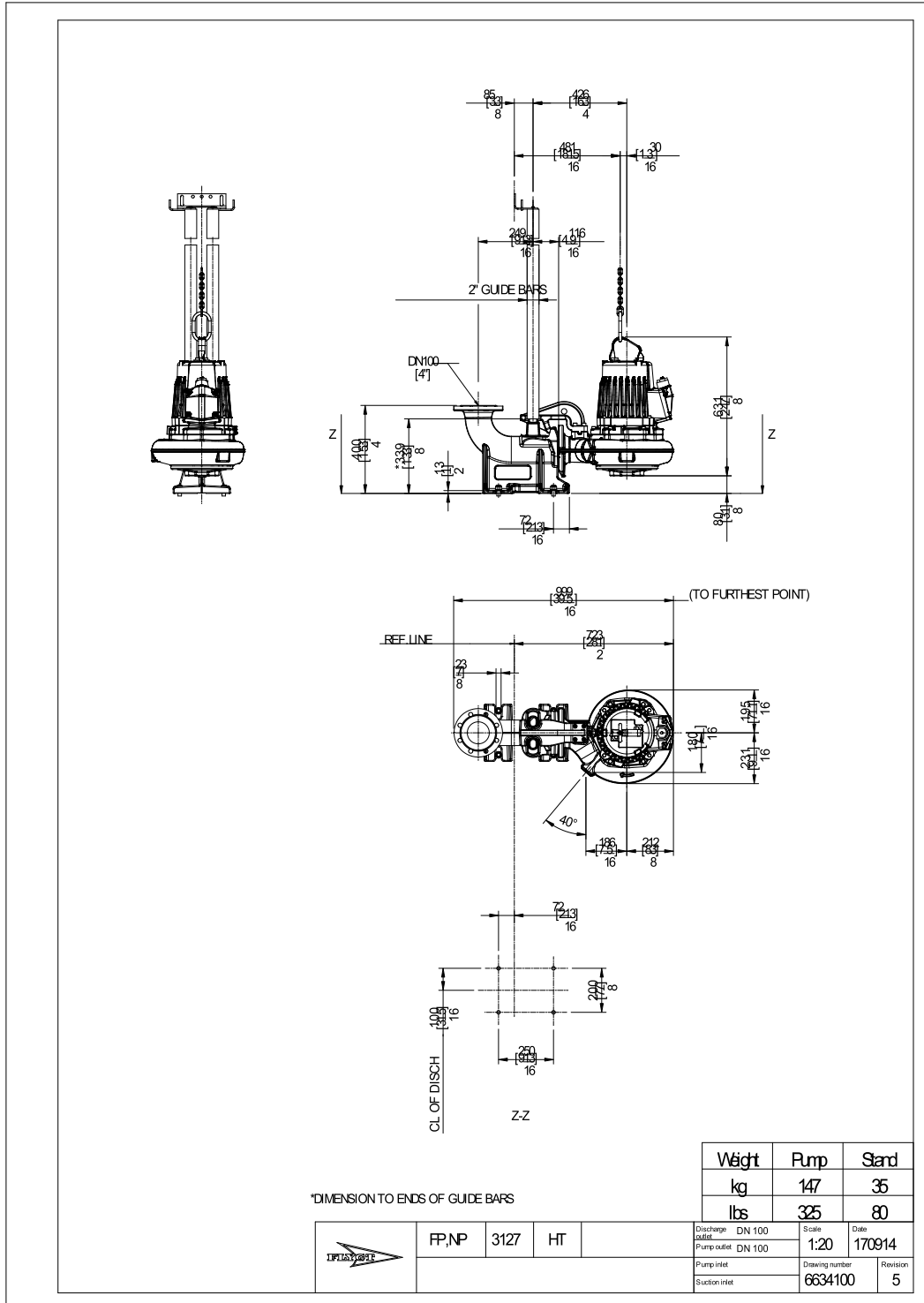

Project omschrijving

Projectnummer

Aangemaakt door:

Aangemaakt op  
9/27/2018

Laatste wijziging