

NP 3127 LT 3~ Adaptive 426

Technische specificaties

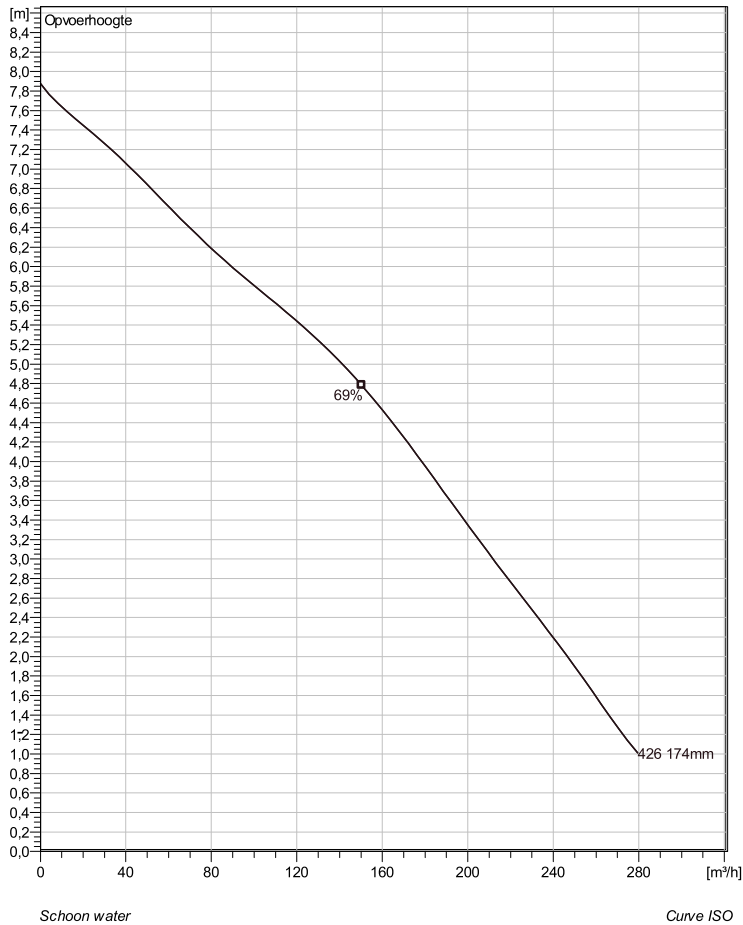

Note: Picture might not correspond to the current configuration.

General

Dompelbare pompen voorzien van verstopingsongevoeilige N-waaiers. Geschikt voor afvalwater met grotere delen zoals rioolwater, regenwater en industriële afvalwater. Materiaal gietijzer.

Impeller

Impeller material	Grey cast iron
Persaansluiting	150 mm
Diameter aanzuigzijde	200 mm
Impeller diameter	174 mm
Aantal bladen	2

Motor

Motor #	N3127.161 21-10-4AL-W 4.7KW standaard
Stator variant	2
Frequentie	50 Hz
Nominale spanning	400 V
Aantal polen	4
Fasen	3~
Nominaal vermogen	4,7 kW
Toegekende stroom	9,6 A
Aanloopstroom	58 A
Nominaal toerental	1445 rpm
Vermogensfactor	
1/1 Load	0,85
3/4 Load	0,81
1/2 Load	0,71
Motor efficiency	
1/1 Load	83,0 %
3/4 Load	83,8 %
1/2 Load	82,4 %

Soort installatie: Semi Permanent, Nat

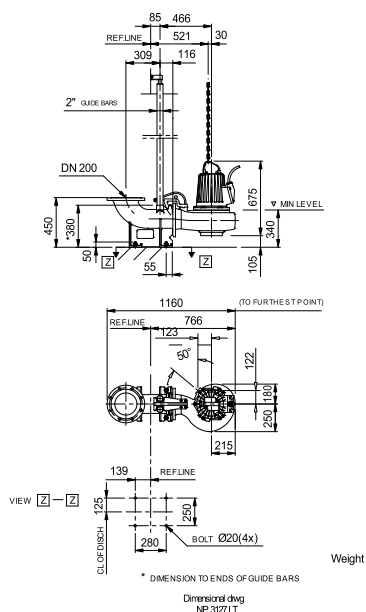

Project omschrijving	Projectnummer	Aangemaakt door:	Aangemaakt op 9/27/2018	Laatste wijziging
----------------------	---------------	------------------	----------------------------	-------------------

NP 3127 LT 3~ Adaptive 426

Karakteristiek

Pomp

Persaansluiting	150 mm
Diameter aanzuigzijde	200 mm
Impeller diameter	174 mm
Aantal bladen	2

Motor

Motor #	N3127.161 21-10-4AL-W 4.7KW
Stator variant	2
Frequentie	50 Hz
Nominale spanning	400 V
Aantal polen	4
Fasen	3~
Nominaal vermogen	4,7 kW
Toegekende stroom	9,6 A
Aanloopstroom	58 A
Nominaal toerental	1445 rpm

Vermogensfactor	
1/1 Load	0,85
3/4 Load	0,81
1/2 Load	0,71
Motor efficiency	
1/1 Load	83,0 %
3/4 Load	83,8 %
1/2 Load	82,4 %

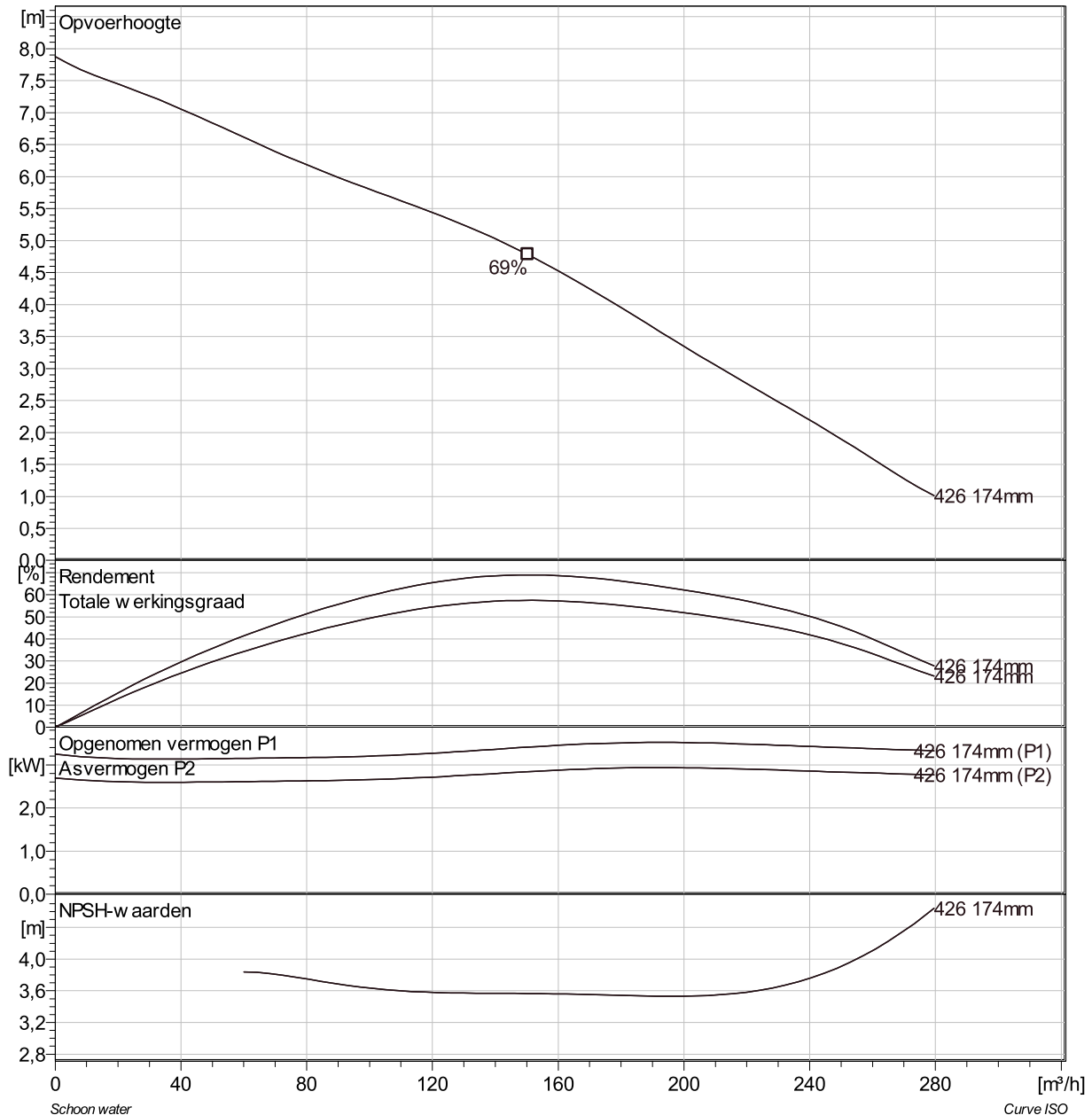

Project omschrijving	Projectnummer	Aangemaakt door:	Aangemaakt op 9/27/2018	Laatste wijziging
----------------------	---------------	------------------	----------------------------	-------------------

NP 3127 LT 3~ Adaptive 426 VFD Analysis

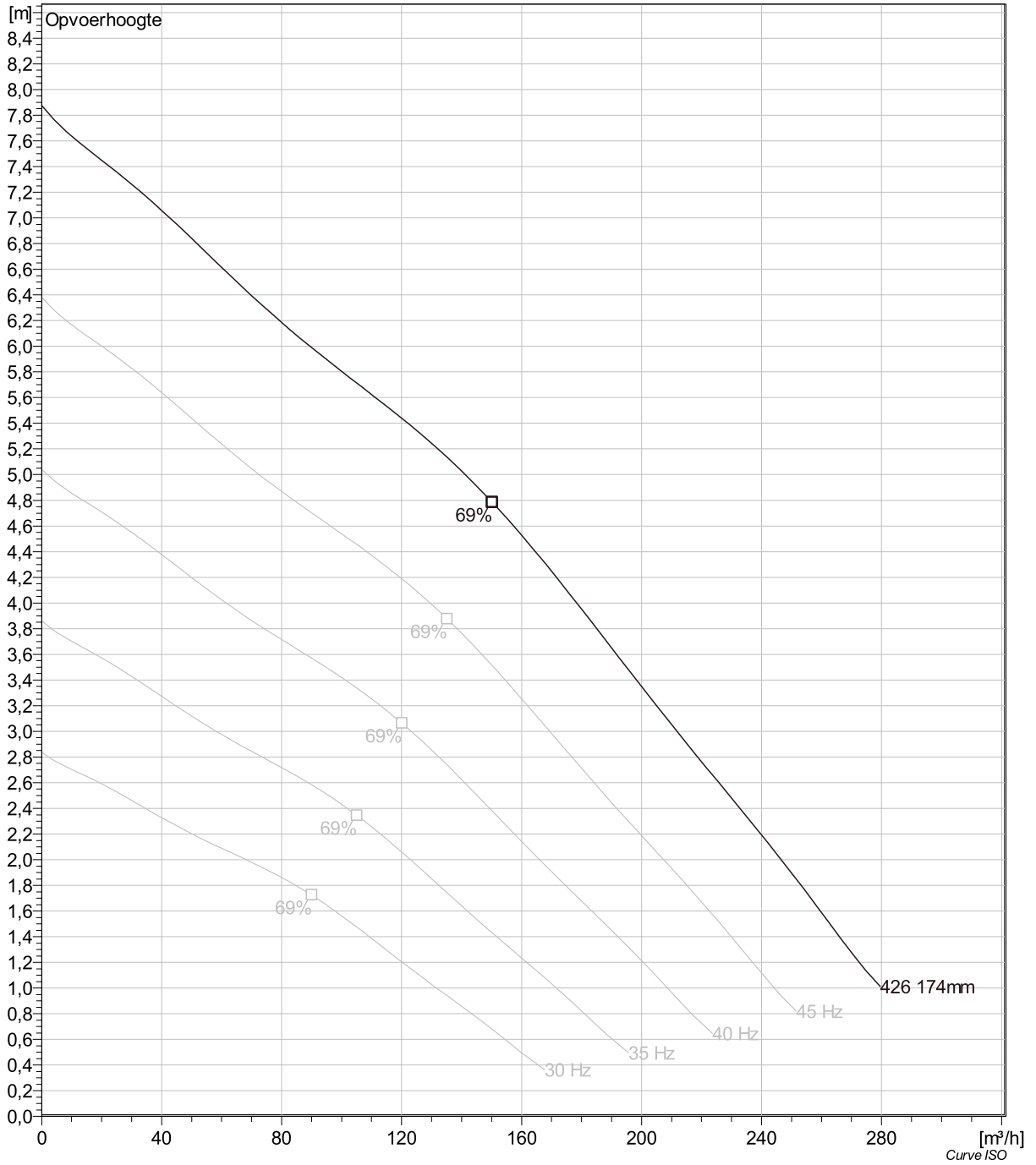

Project omschrijving	Projectnummer	Aangemaakt door:	Aangemaakt op 9/27/2018	Laatste wijziging
----------------------	---------------	------------------	----------------------------	-------------------

NP 3127 LT 3~ Adaptive 426 Dimensional drawing

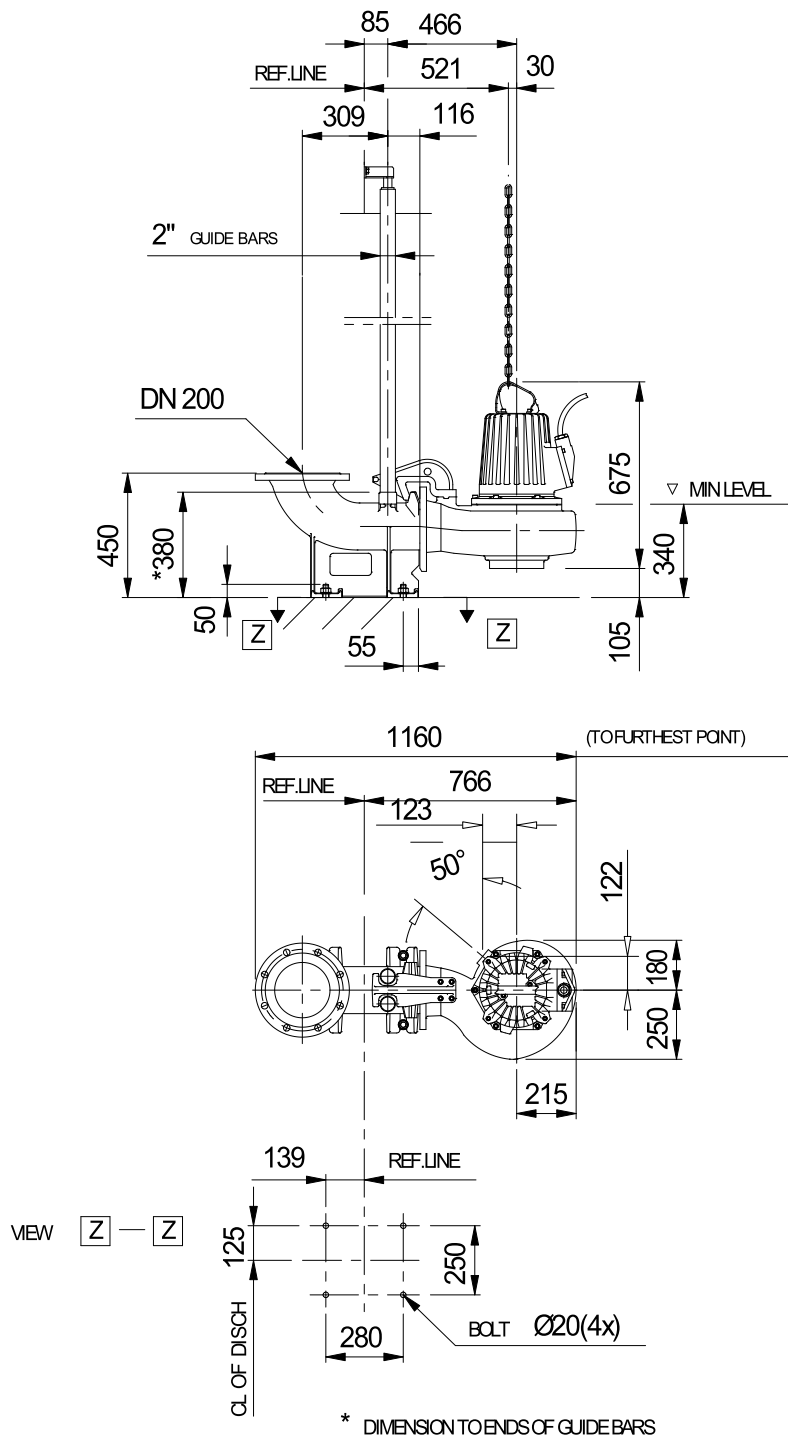

Weight

Dimensional dwg
NP3127LT

Project omschrijving	Projectnummer	Aangemaakt door:	Aangemaakt op 9/27/2018	Laatste wijziging
----------------------	---------------	------------------	----------------------------	-------------------