

NS 3127 SH 3~ Adaptive 247

Karakteristiek

Pomp

Persaansluiting 80 mm
 Diameter aanzuigzijde 90 mm
 Impeller diameter 164 mm
 Aantal bladen 2

Motor

Motor # N3127.161 21-11-2AL-W 7.4KW
 Stator variant 28
 Frequentie 50 Hz
 Nominale spanning 190 V
 Aantal polen 2
 Fasen 3~
 Nominaal vermogen 7,4 kW
 Toegekende stroom 30 A
 Aanloopstroom 274 A
 Nominaal toerental 2910 rpm

Vermogensfactor
 1/1 Load 0,85
 3/4 Load 0,79
 1/2 Load 0,69
 Rendement
 1/1 Load 87,5 %
 3/4 Load 87,9 %
 1/2 Load 86,7 %

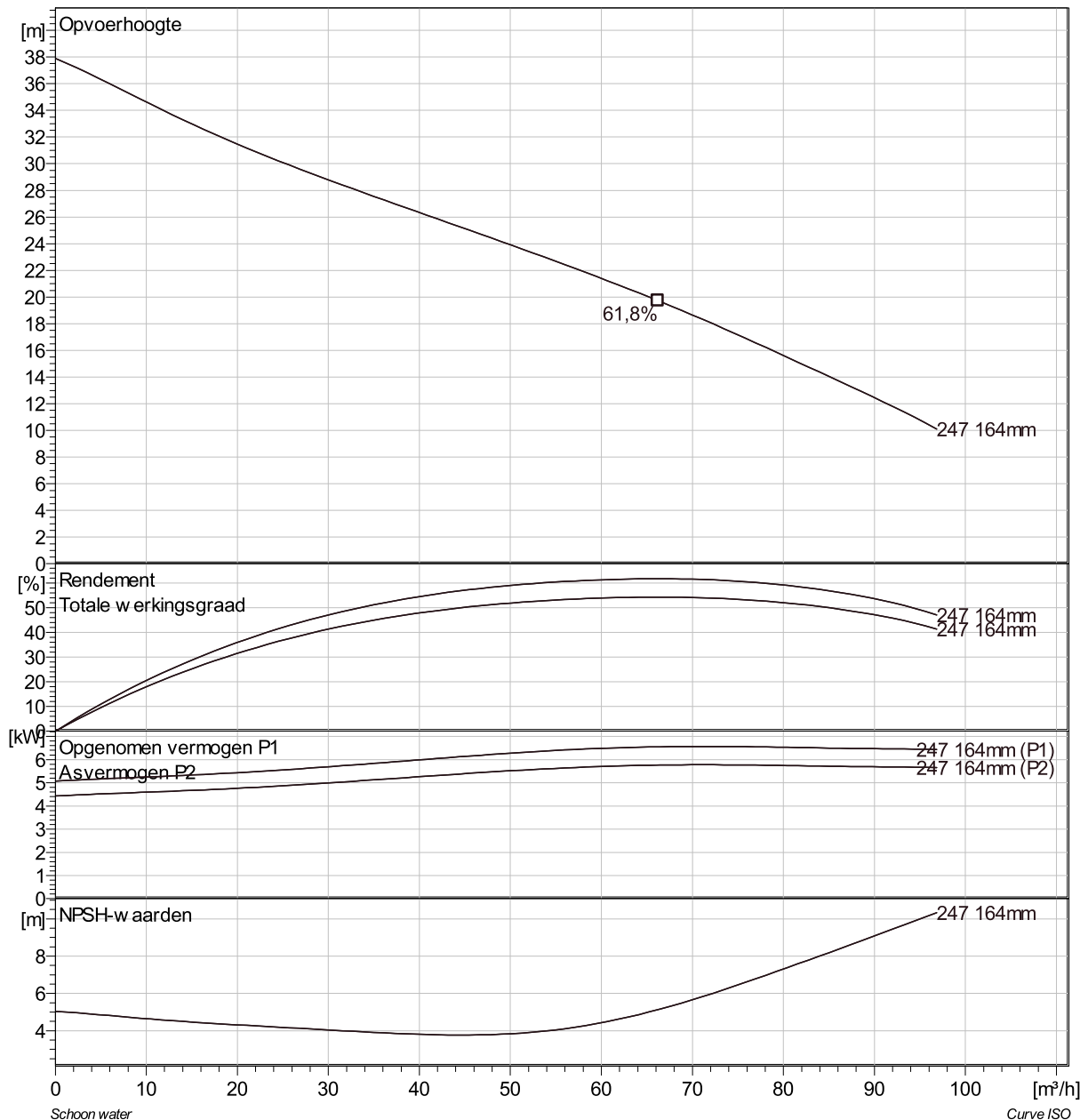

Project	Project ID	Created by	Created on 10/5/2018	Last update
---------	------------	------------	-------------------------	-------------

NS 3127 SH 3~ Adaptive 247 VFD Analysis

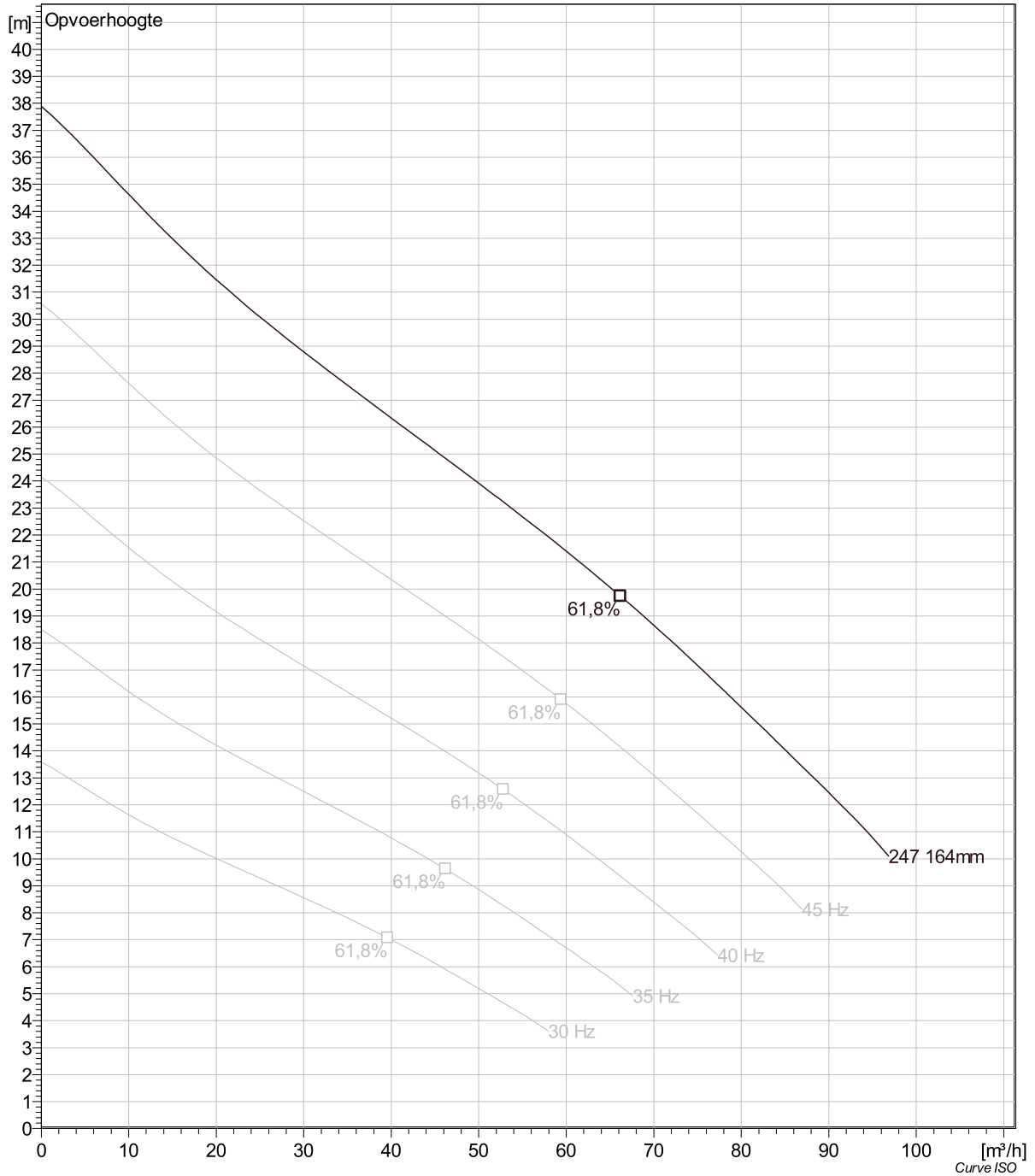

Project	Project ID	Created by	Created on	Last update
			10/5/2018	

NS 3127 SH 3~ Adaptive 247 Dimensional drawing

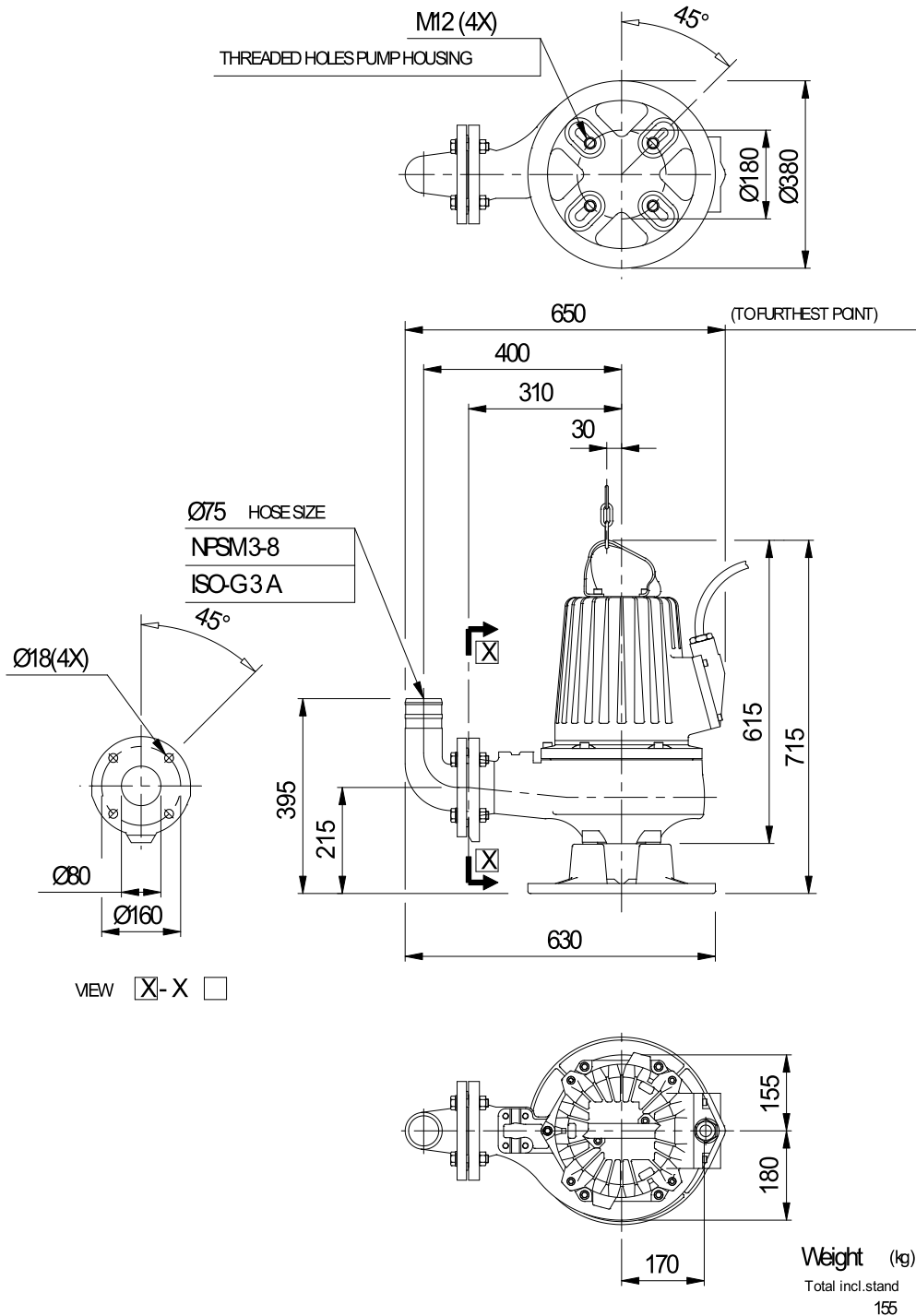

Dimensional dwg
FS, NS3127 SH

Project	Project ID	Created by	Created on	Last update
			10/5/2018	