

NP 3153 HT 3~ 450 Technische specificaties

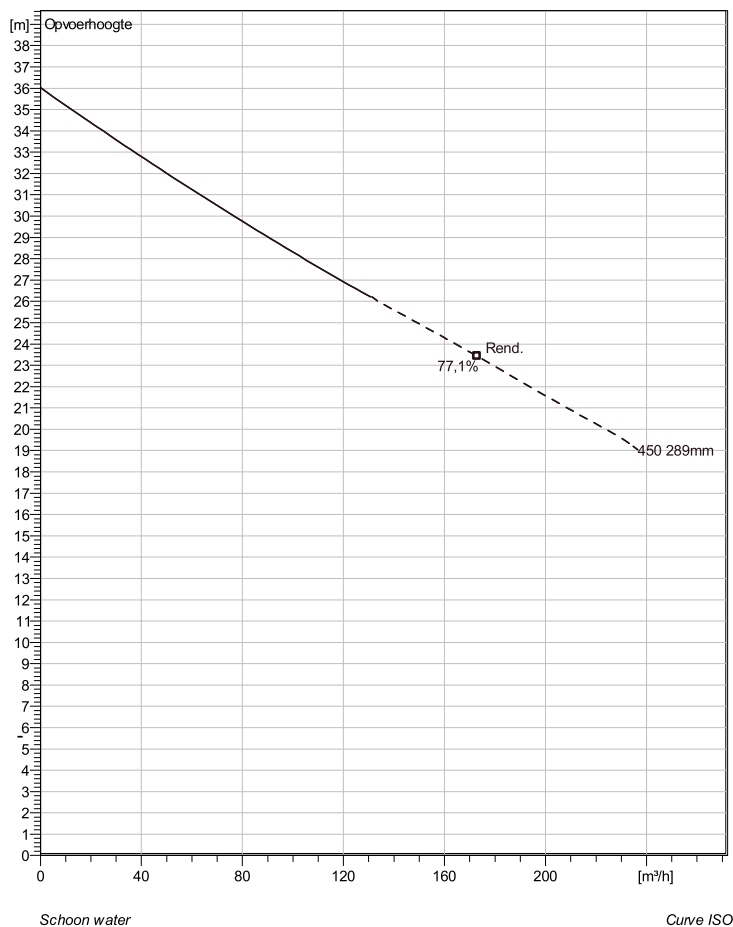

Note: Picture might not correspond to the current configuration.

General

Dompelbare pompen voorzien van een verstoppingsonevulnerable N-waaiër. Geschikt voor afvalwater met grotere delen zoals rioolwater, regenwater en industriële afvalwater. Materiaal gietijzer.

Impeller

Impeller material	Grey cast iron
Persaansluiting	100 mm
Diameter aanzuigzijde	100 mm
Impeller diameter	289 mm
Aantal bladen	2

Soort installatie: Semi Permanent, Nat

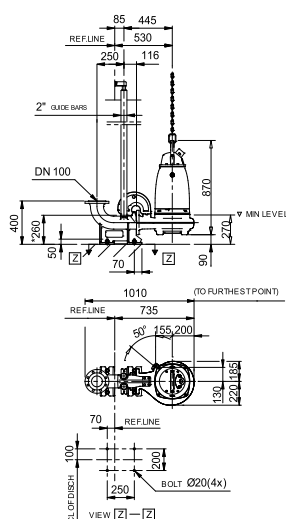

* DIMENSION TO ENDS OF GUIDE BARS

Weight

Dimensional dwg
NP-PP-3153HT

Motor

Motor #	N3153.800 21-18-4XS-W IE3 12.5KW standaard
Stator variant	2
Frequentie	50 Hz
Nominale spanning	400 V
Aantal polen	4
Fasen	3~
Nominaal vermogen	12,5 kW
Toegekende stroom	21 A
Aanloopstroom	145 A
Nominaal toerental	1500 rpm
Vermogensfactor	
1/1 Load	0,95
3/4 Load	0,95
1/2 Load	0,90
Motor efficiency	
1/1 Load	91,8 %
3/4 Load	92,8 %
1/2 Load	92,1 %

Project omschrijving	Projectnummer	Aangemaakt door:	Aangemaakt op 9/27/2018	Laatste wijziging
----------------------	---------------	------------------	----------------------------	-------------------

NP 3153 HT 3~ 450

Karakteristiek

Pomp

Persaansluiting	100 mm
Diameter aanzuigzijde	100 mm
Impeller diameter	289 mm
Aantal bladen	2

Motor

Motor #	N3153.800 21-18-4XS-W IE3 12.5KW
Stator variant	2
Frequentie	50 Hz
Nominale spanning	400 V
Aantal polen	4
Fasen	3~
Nominaal vermogen	12,5 kW
Toegekende stroom	21 A
Aanloopstroom	145 A
Nominaal toerental	1500 rpm

Vermogensfactor	
1/1 Load	0,95
3/4 Load	0,95
1/2 Load	0,90
Motor efficiency	
1/1 Load	91,8 %
3/4 Load	92,8 %
1/2 Load	92,1 %

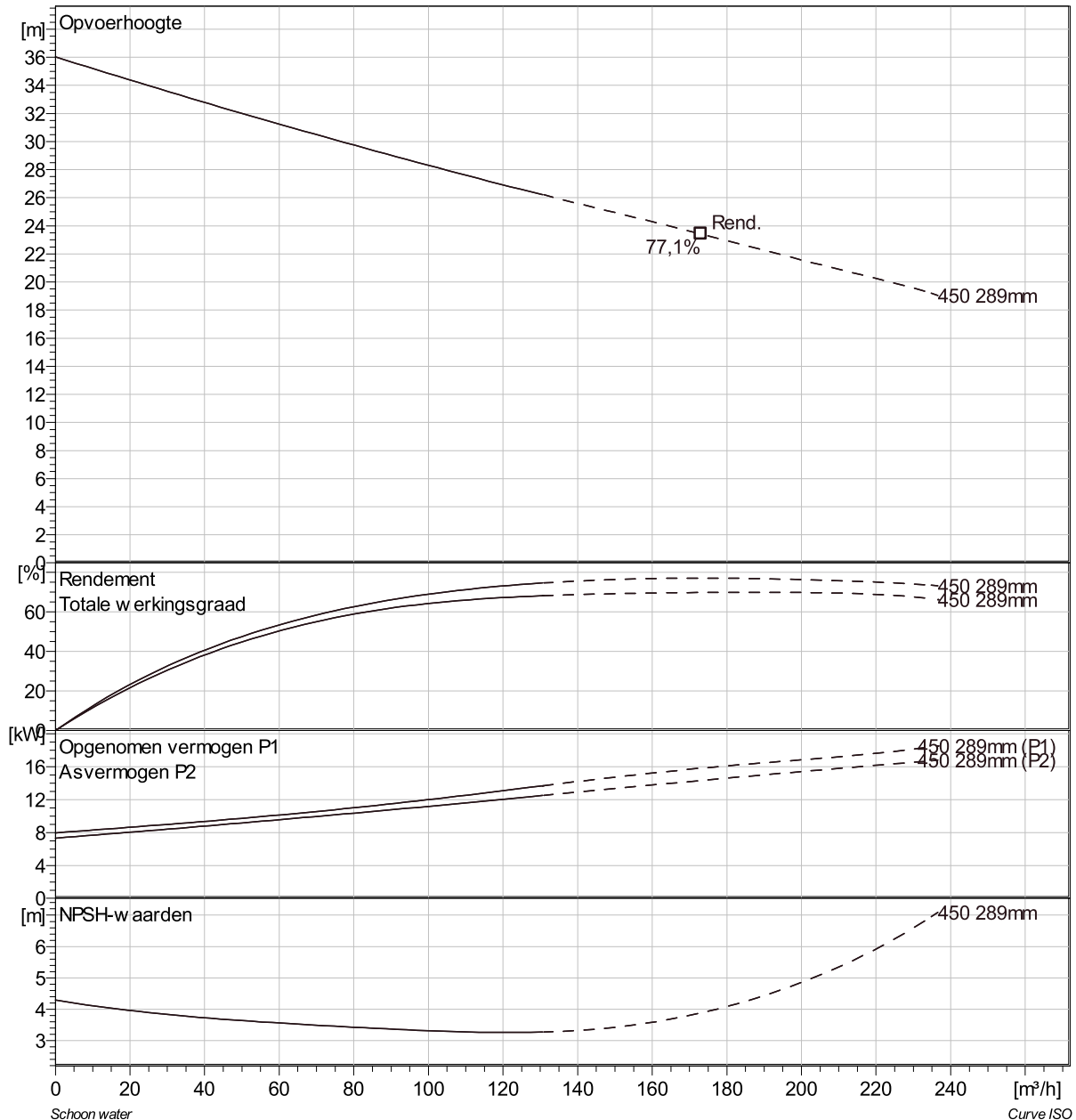

Project omschrijving	Projectnummer	Aangemaakt door:	Aangemaakt op 9/27/2018	Laatste wijziging
----------------------	---------------	------------------	----------------------------	-------------------

NP 3153 HT 3~ 450 VFD Analysis

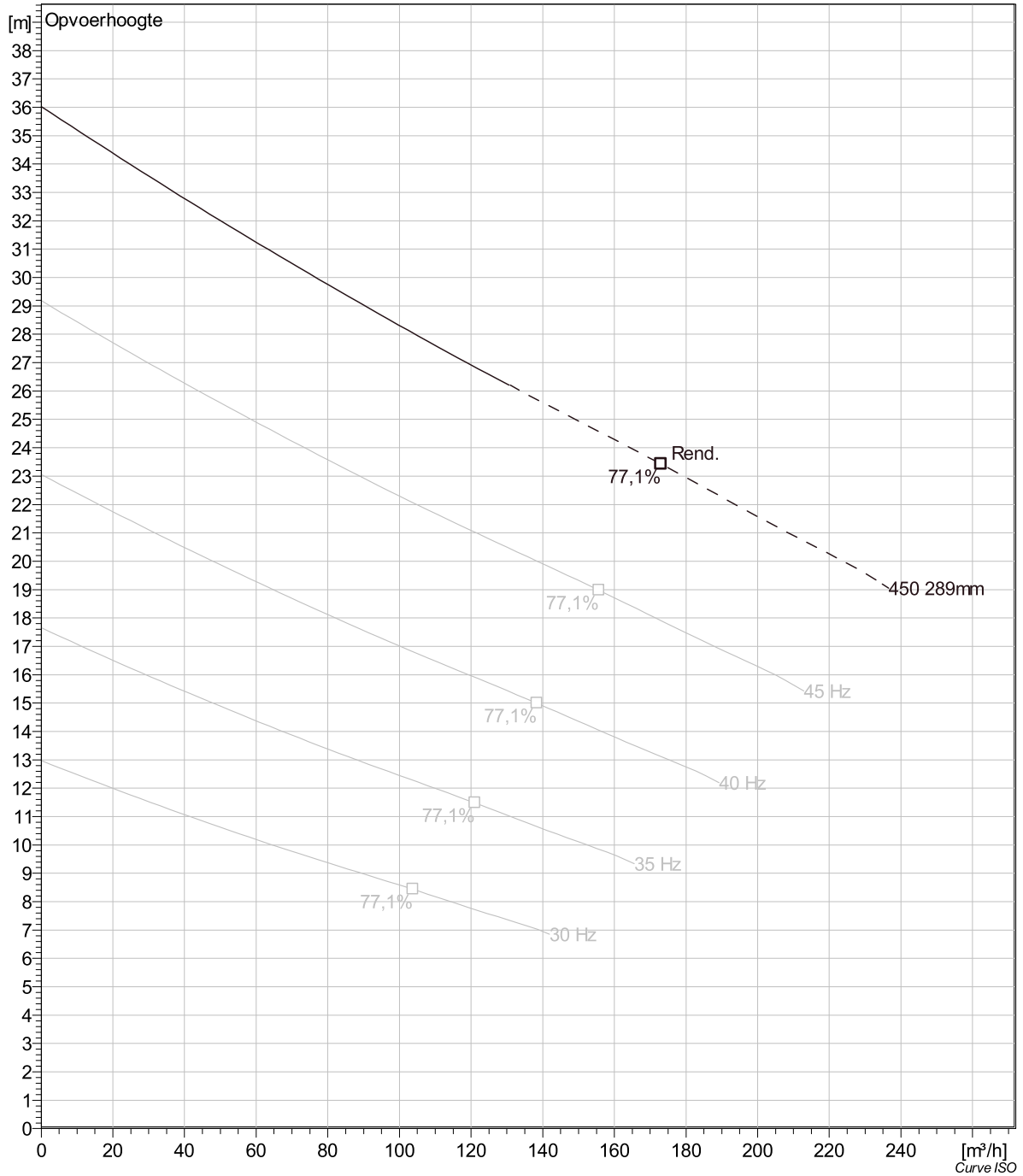

Project omschrijving	Projectnummer	Aangemaakt door:	Aangemaakt op 9/27/2018	Laatste wijziging
----------------------	---------------	------------------	----------------------------	-------------------

NP 3153 HT 3~ 450 Dimensional drawing

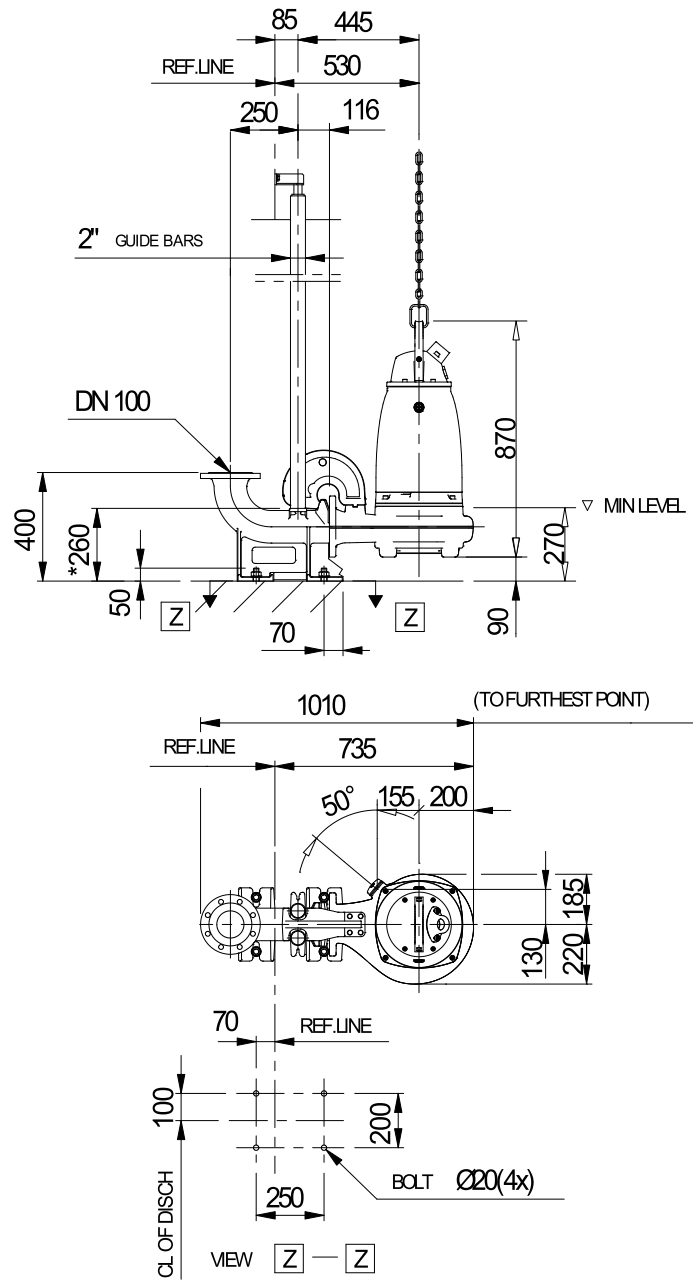

* DIMENSION TO ENDS OF GUIDE BARS

Weight

Dimensional dwg
NP,FP3153HT

Project omschrijving	Projectnummer	Aangemaakt door:	Aangemaakt op 9/27/2018	Laatste wijziging
----------------------	---------------	------------------	----------------------------	-------------------