

## NP 3153 HT 3~ 451 Technische specificaties

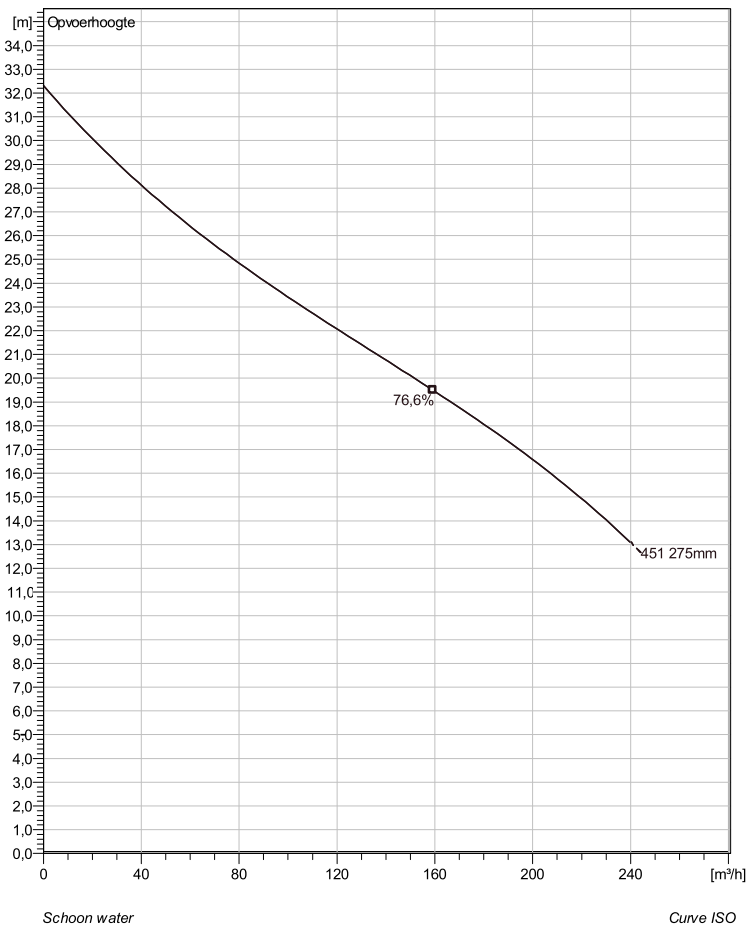

Note: Picture might not correspond to the current configuration.

### General

Dompelpbare pompen voorzien van een verstoppingsgevoelige N-waaijer. Geschikt voor afvalwater met grotere delen zoals rioolwater, regenwater en industriële afvalwater. Materiaal gietijzer.

### Impeller

|                       |                |
|-----------------------|----------------|
| Impeller material     | Grey cast iron |
| Persaansluiting       | 100 mm         |
| Diameter aanzuigzijde | 100 mm         |
| Impeller diameter     | 275 mm         |
| Aantal bladen         | 2              |

### Motor

|                    |  |
|--------------------|--|
| Motor #            | N3153.181 21-18-4AA-W 13.5KW standaard |
| Stator variant     | 2                                      |
| Frequentie         | 50 Hz                                  |
| Nominale spanning  | 400 V                                  |
| Aantal polen       | 4                                      |
| Fasen              | 3~                                     |
| Nominaal vermogen  | 13,5 kW                                |
| Toegekende stroom  | 27 A                                   |
| Aanloopstroom      | 145 A                                  |
| Nominaal toerental | 1455 rpm                               |
| Vermogensfactor    |  |
| 1/1 Load           | 0,84                                   |
| 3/4 Load           | 0,79                                   |
| 1/2 Load           | 0,68                                   |
| Motor efficiency   |  |
| 1/1 Load           | 86,5 %                                 |
| 3/4 Load           | 88,0 %                                 |
| 1/2 Load           | 88,5 %                                 |

### Soort installatie: Semi Permanent, Nat

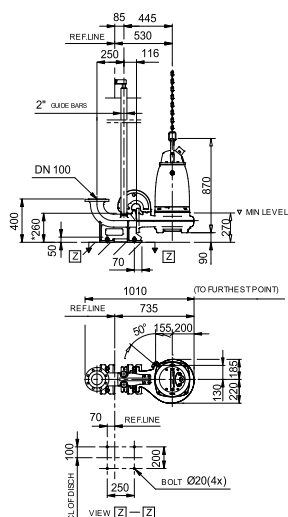

Weight

Dimensional dwg  
NP-PP-3153HT

|                      |               |                  |                            |                   |
|----------------------|---------------|------------------|----------------------------|-------------------|
| Project omschrijving | Projectnummer | Aangemaakt door: | Aangemaakt op<br>9/27/2018 | Laatste wijziging |
|----------------------|---------------|------------------|----------------------------|-------------------|

## NP 3153 HT 3~ 451

### Karakteristiek

#### Pomp

|                       |        |
|-----------------------|--------|
| Persaansluiting       | 100 mm |
| Diameter aanzuigzijde | 100 mm |
| Impeller diameter     | 275 mm |
| Aantal bladen         | 2      |

#### Motor

|                    |                              |
|--------------------|------------------------------|
| Motor #            | N3153.181 21-18-4AA-W 13.5KW |
| Stator variant     | 2                            |
| Frequentie         | 50 Hz                        |
| Nominale spanning  | 400 V                        |
| Aantal polen       | 4                            |
| Fasen              | 3~                           |
| Nominaal vermogen  | 13,5 kW                      |
| Toegekende stroom  | 27 A                         |
| Aanloopstroom      | 145 A                        |
| Nominaal toerental | 1455 rpm                     |

|                  |        |
|------------------|--------|
| Vermogensfactor  |        |
| 1/1 Load         | 0,84   |
| 3/4 Load         | 0,79   |
| 1/2 Load         | 0,68   |
| Motor efficiency |        |
| 1/1 Load         | 86,5 % |
| 3/4 Load         | 88,0 % |
| 1/2 Load         | 88,5 % |

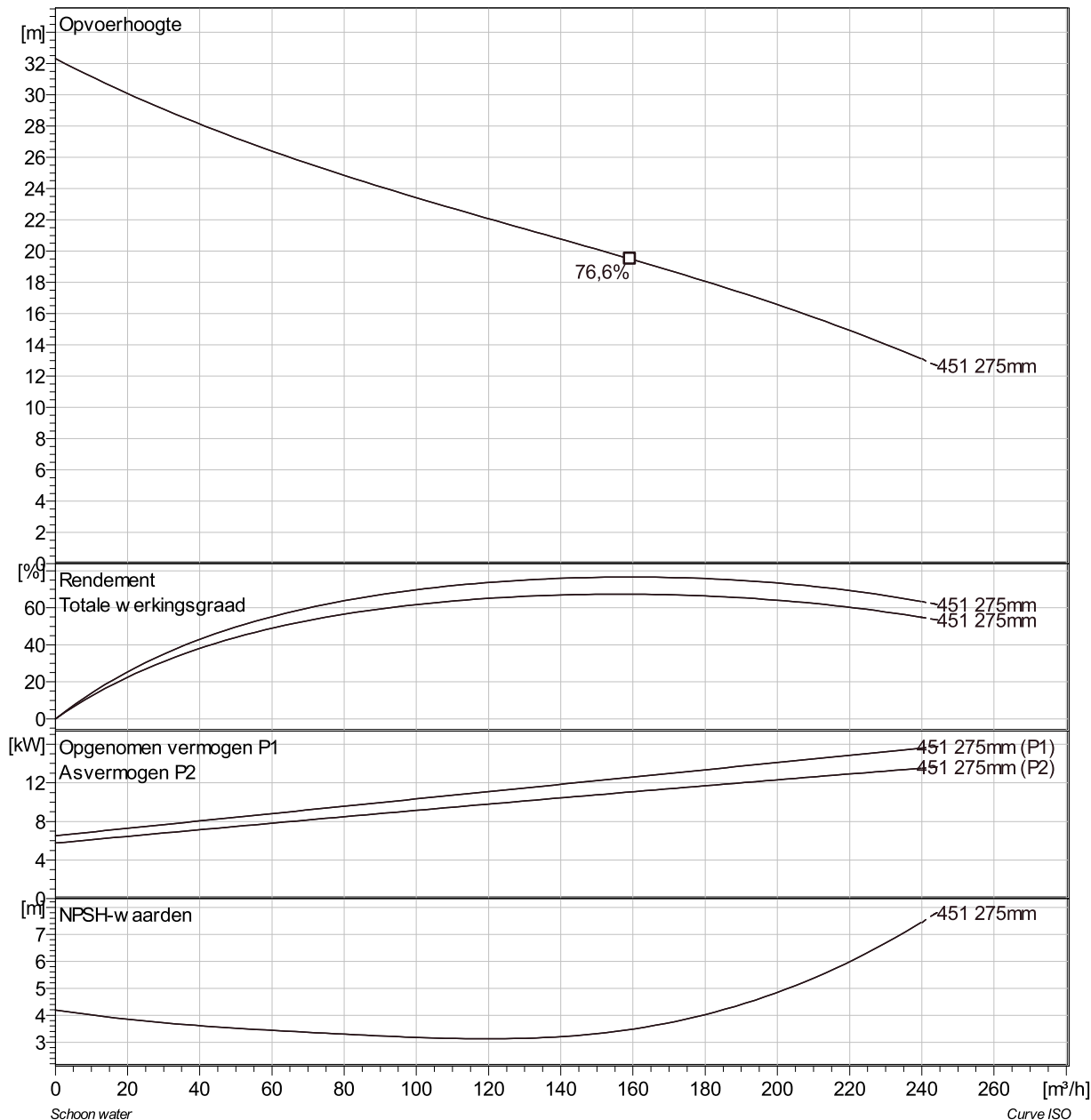

|                      |               |                  |                            |                   |
|----------------------|---------------|------------------|----------------------------|-------------------|
| Project omschrijving | Projectnummer | Aangemaakt door: | Aangemaakt op<br>9/27/2018 | Laatste wijziging |
|----------------------|---------------|------------------|----------------------------|-------------------|

## NP 3153 HT 3~ 451 VFD Analysis

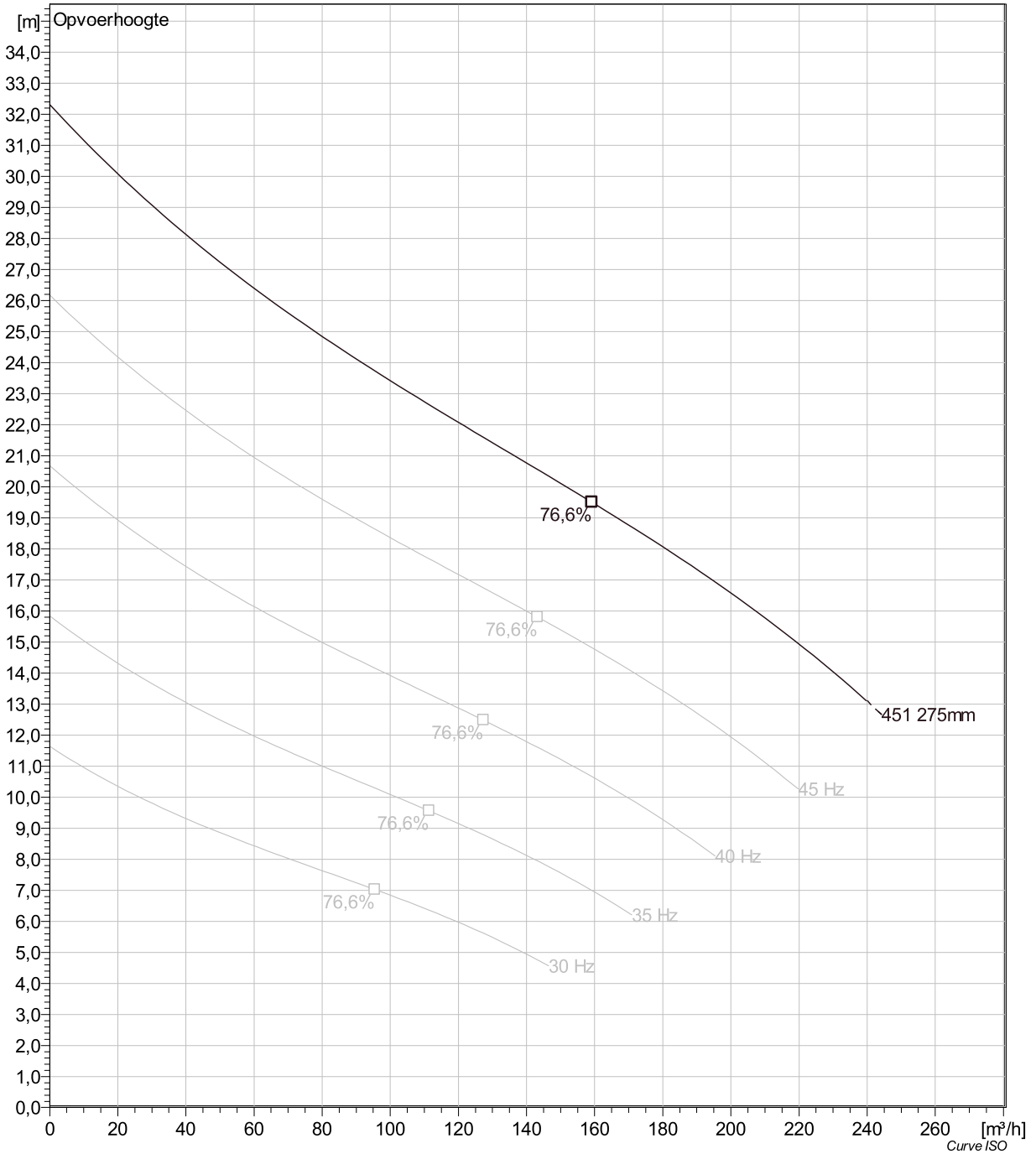

|                      |               |                  |                            |                   |
|----------------------|---------------|------------------|----------------------------|-------------------|
| Project omschrijving | Projectnummer | Aangemaakt door: | Aangemaakt op<br>9/27/2018 | Laatste wijziging |
|----------------------|---------------|------------------|----------------------------|-------------------|

## NP 3153 HT 3~ 451 Dimensional drawing

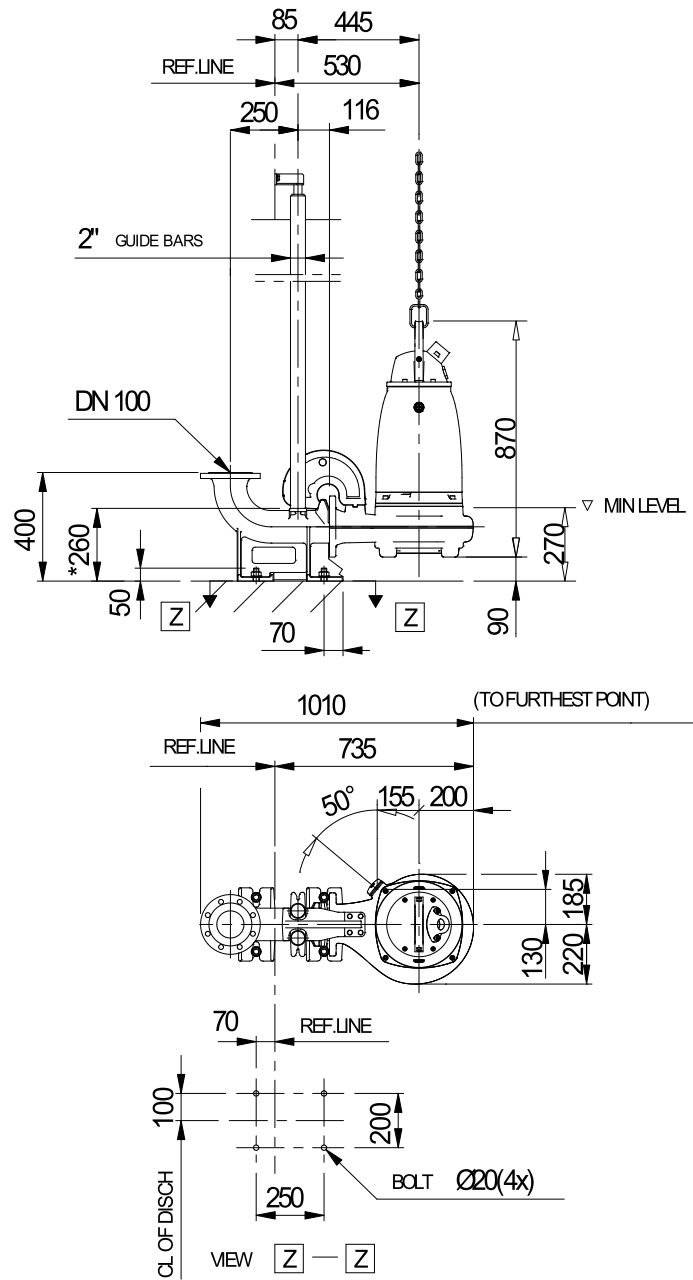

\* DIMENSION TO ENDS OF GUIDE BARS

Weight

Dimensional dwg  
NP,FP3153HT

|                      |               |                  |                            |                   |
|----------------------|---------------|------------------|----------------------------|-------------------|
| Project omschrijving | Projectnummer | Aangemaakt door: | Aangemaakt op<br>9/27/2018 | Laatste wijziging |
|----------------------|---------------|------------------|----------------------------|-------------------|