

## NP 3153 HT 3~ 454

### Technische specificaties

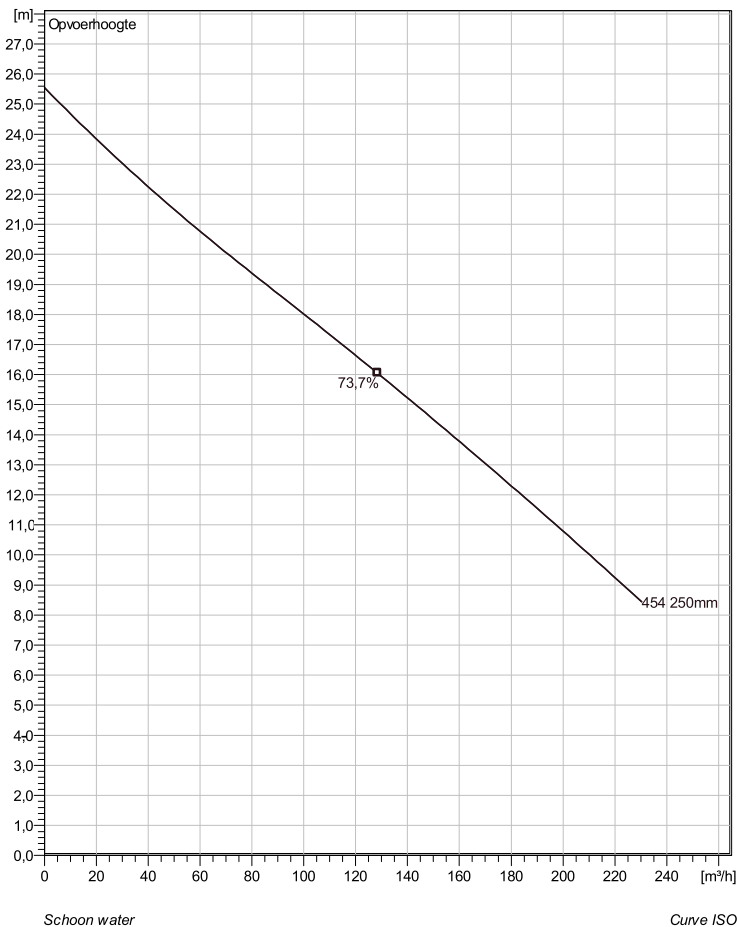

Note: Picture might not correspond to the current configuration.

#### General

Dompelbare pompen voorzien van een verstoppingsgevoelige N-waaijer. Geschikt voor afvalwater met grotere delen zoals rioolwater, regenwater en industriële afvalwater. Materiaal gietijzer.

#### Impeller

Impeller material	Grey cast iron
Persaansluiting	100 mm
Diameter aanzuigzijde	100 mm
Impeller diameter	250 mm
Aantal bladen	2

#### Motor

Motor #	N3153.181 21-18-4AA-W 13.5KW standaard
Stator variant	2
Frequentie	50 Hz
Nominale spanning	400 V
Aantal polen	4
Fasen	3~
Nominaal vermogen	13,5 kW
Toegekende stroom	27 A
Aanloopstroom	145 A
Nominaal toerental	1455 rpm
Vermogensfactor	
1/1 Load	0,84
3/4 Load	0,79
1/2 Load	0,68
Motor efficiency	
1/1 Load	86,5 %
3/4 Load	88,0 %
1/2 Load	88,5 %

#### Soort installatie: Semi Permanent, Nat

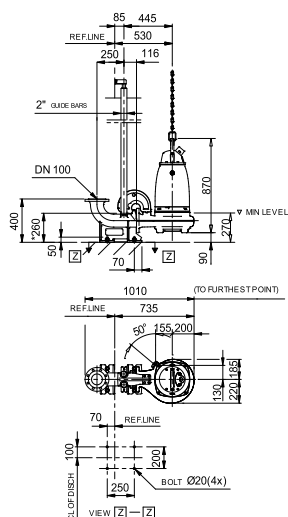

\* DIMENSION TO ENDS OF GUIDE BARS

Weight

Dimensional dwg  
NP-PP-3153HT

Project omschrijving	Projectnummer	Aangemaakt door:	Aangemaakt op 9/27/2018	Laatste wijziging
----------------------	---------------	------------------	----------------------------	-------------------

## NP 3153 HT 3~ 454

### Karakteristiek

#### Pomp

Persaansluiting	100 mm
Diameter aanzuigzijde	100 mm
Impeller diameter	250 mm
Aantal bladen	2

#### Motor

Motor #	N3153.181 21-18-4AA-W 13.5KW
Stator variant	2
Frequentie	50 Hz
Nominale spanning	400 V
Aantal polen	4
Fasen	3~
Nominaal vermogen	13,5 kW
Toegekende stroom	27 A
Aanloopstroom	145 A
Nominaal toerental	1455 rpm

Vermogensfactor	
1/1 Load	0,84
3/4 Load	0,79
1/2 Load	0,68
Motor efficiency	
1/1 Load	86,5 %
3/4 Load	88,0 %
1/2 Load	88,5 %

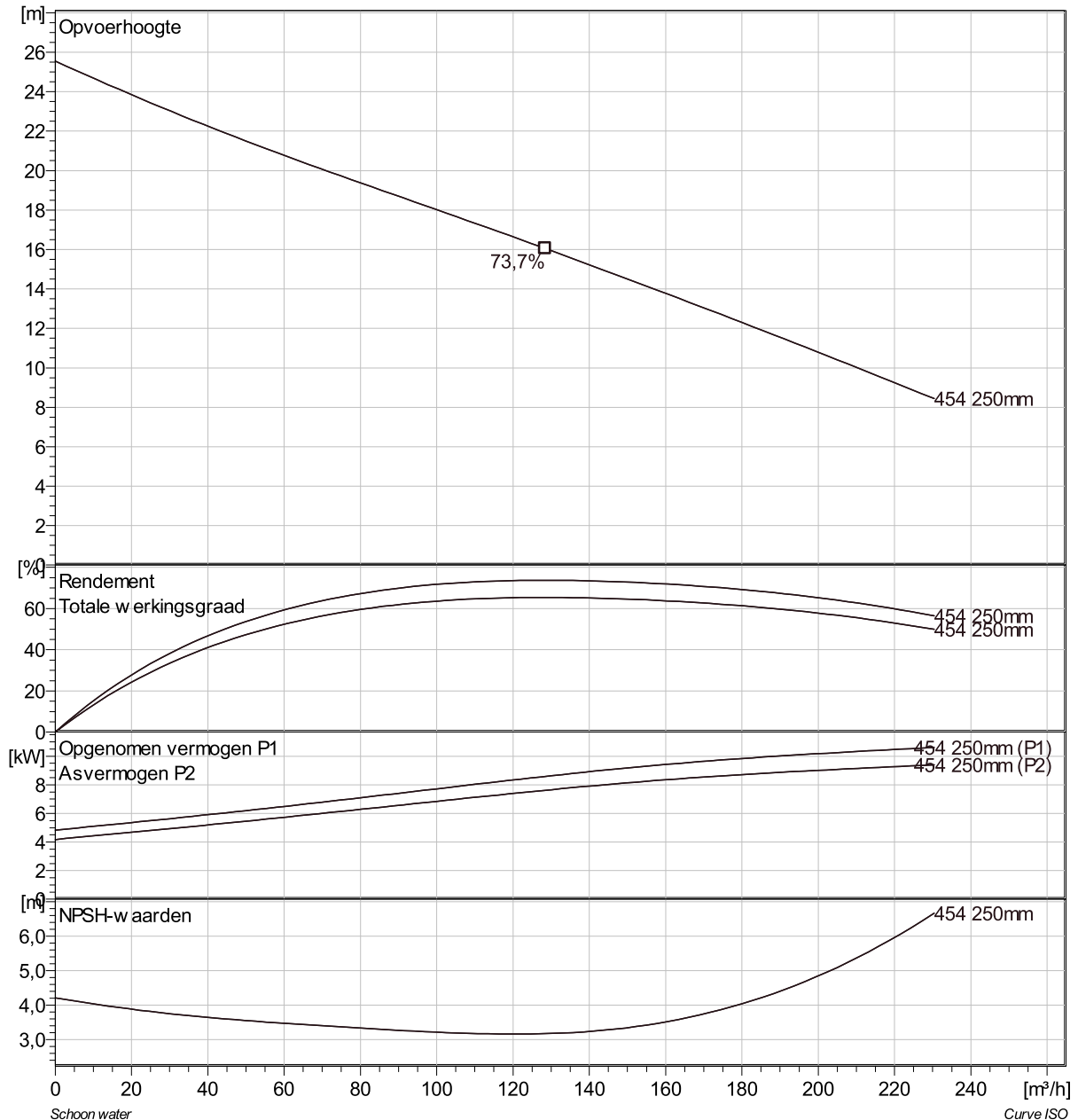

Project omschrijving	Projectnummer	Aangemaakt door:	Aangemaakt op 9/27/2018	Laatste wijziging
----------------------	---------------	------------------	----------------------------	-------------------

## NP 3153 HT 3~ 454

### VFD Analysis

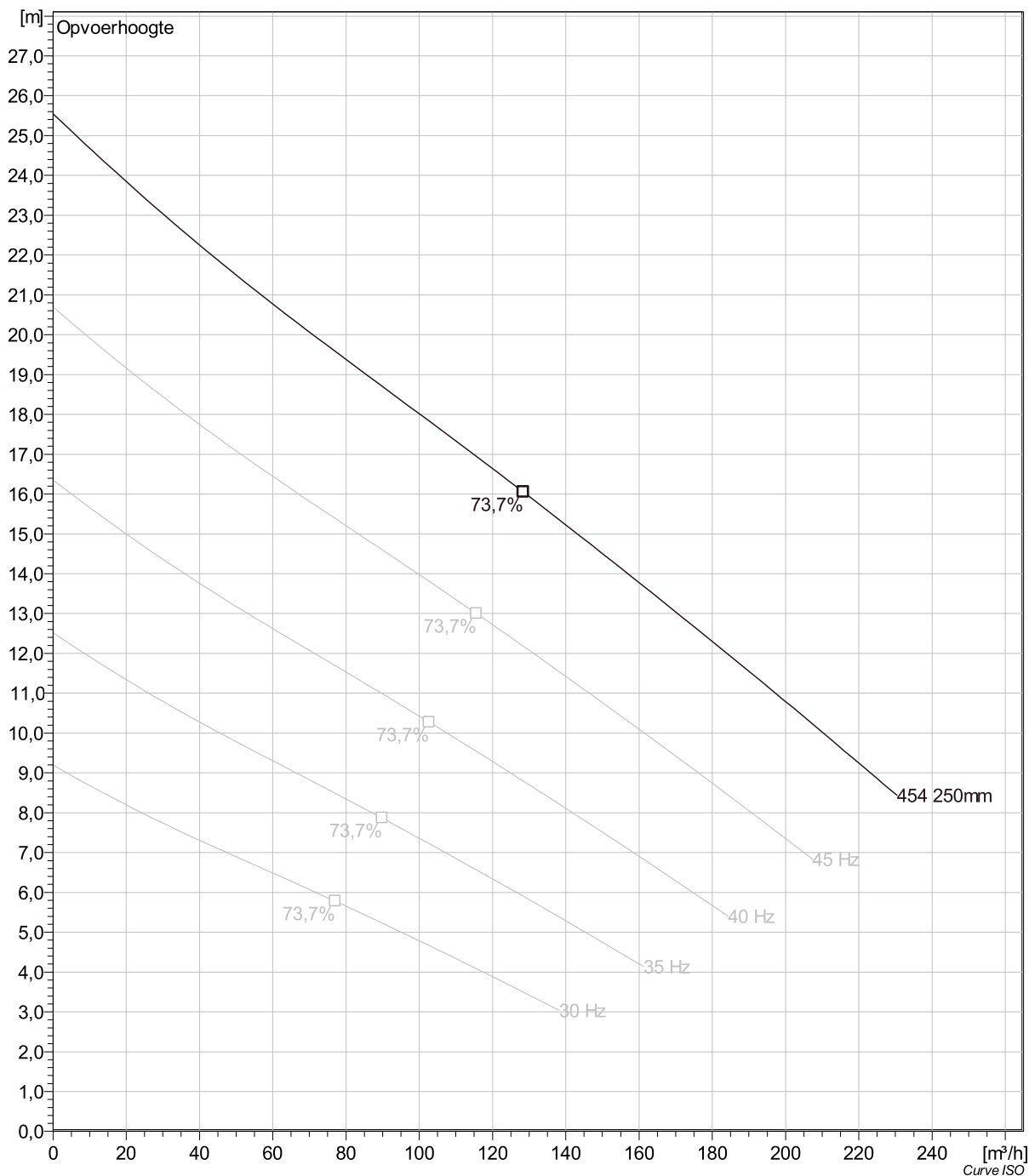

Project omschrijving	Projectnummer	Aangemaakt door:	Aangemaakt op 9/27/2018	Laatste wijziging
----------------------	---------------	------------------	----------------------------	-------------------

## NP 3153 HT 3~ 454 Dimensional drawing

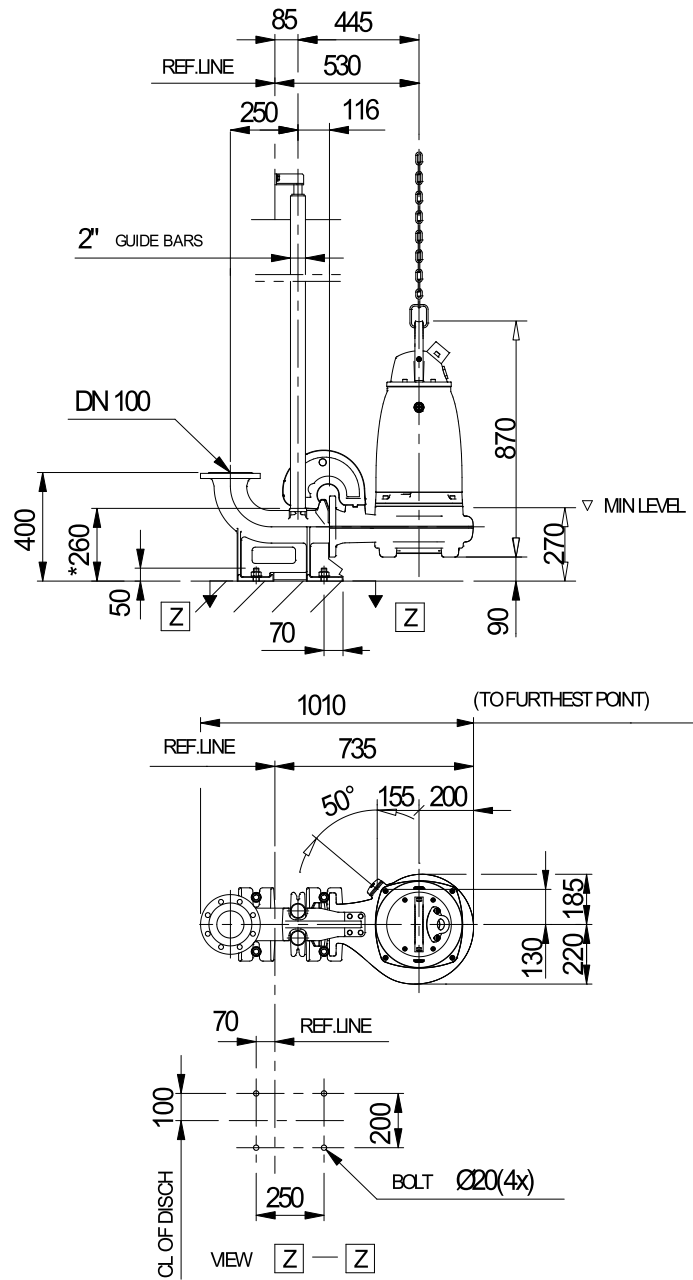

\* DIMENSION TO ENDS OF GUIDE BARS

Weight

Dimensional dwg  
NP,FP3153HT

Project omschrijving	Projectnummer	Aangemaakt door:	Aangemaakt op 9/27/2018	Laatste wijziging
----------------------	---------------	------------------	----------------------------	-------------------