

NP 3153 HT 3~ 455

Technische specificaties

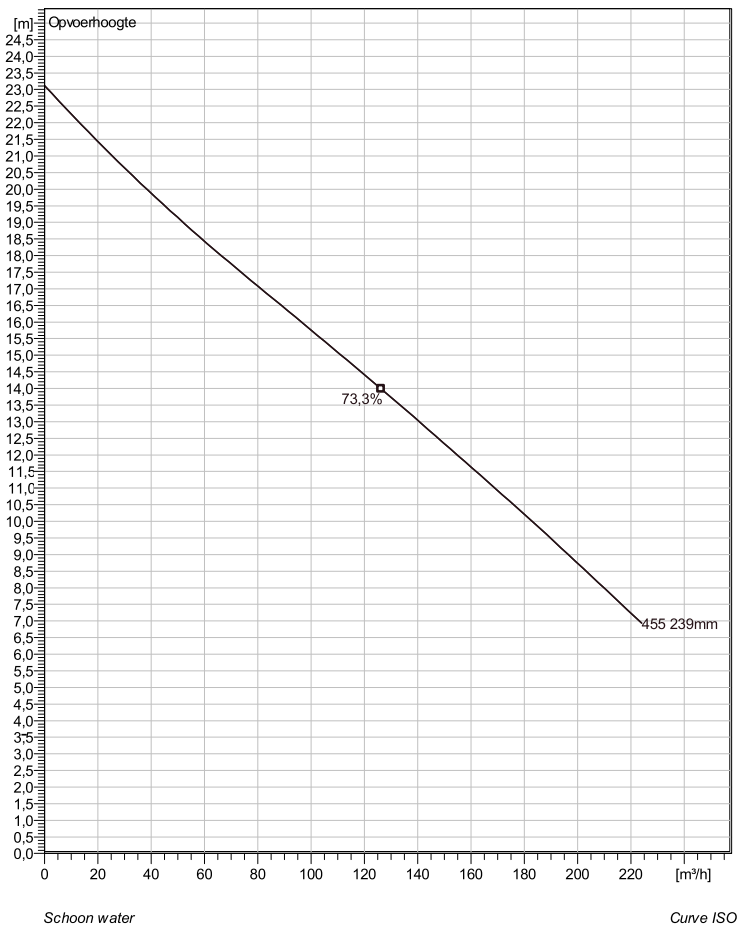

Note: Picture might not correspond to the current configuration.

General

Dompelbare pompen voorzien van een verstoppingsgevoelige N-waai. Geschikt voor afvalwater met grotere delen zoals rioolwater, regenwater en industriële afvalwater. Materiaal gietijzer.

Impeller

Impeller material	Grey cast iron
Persaansluiting	100 mm
Diameter aanzuigzijde	100 mm
Impeller diameter	239 mm
Aantal bladen	2

Motor

Motor #	N3153.181 21-15-4AA-W 9KW standaard
Stator variant	2
Frequentie	50 Hz
Nominale spanning	400 V
Aantal polen	4
Fasen	3~
Nominaal vermogen	9 kW
Toegekende stroom	19 A
Aanloopstroom	105 A
Nominaal toerental	1460 rpm
Vermogensfactor	
1/1 Load	0,81
3/4 Load	0,75
1/2 Load	0,62
Motor efficiency	
1/1 Load	86,0 %
3/4 Load	87,0 %
1/2 Load	86,5 %

Soort installatie: Semi Permanent, Nat

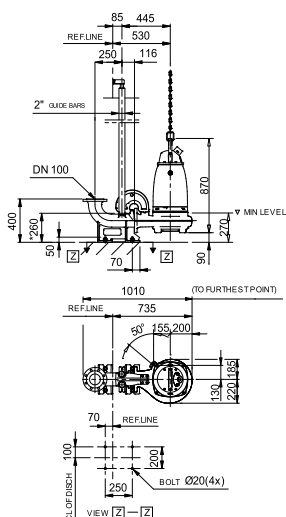

* DIMENSION TO ENDS OF GUIDE BARS

Weight

Dimensional dwg
NP-PP-3153HT

Project omschrijving	Projectnummer	Aangemaakt door:	Aangemaakt op 9/27/2018	Laatste wijziging
----------------------	---------------	------------------	----------------------------	-------------------

NP 3153 HT 3~ 455

Karakteristiek

Pomp

Persaansluiting	100 mm
Diameter aanzuigzijde	100 mm
Impeller diameter	239 mm
Aantal bladen	2

Motor

Motor #	N3153.181 21-15-4AA-W 9KW
Stator variant	2
Frequentie	50 Hz
Nominale spanning	400 V
Aantal polen	4
Fasen	3~
Nominaal vermogen	9 kW
Toegekende stroom	19 A
Aanloopstroom	105 A
Nominaal toerental	1460 rpm

Vermogensfactor	
1/1 Load	0,81
3/4 Load	0,75
1/2 Load	0,62
Motor efficiency	
1/1 Load	86,0 %
3/4 Load	87,0 %
1/2 Load	86,5 %

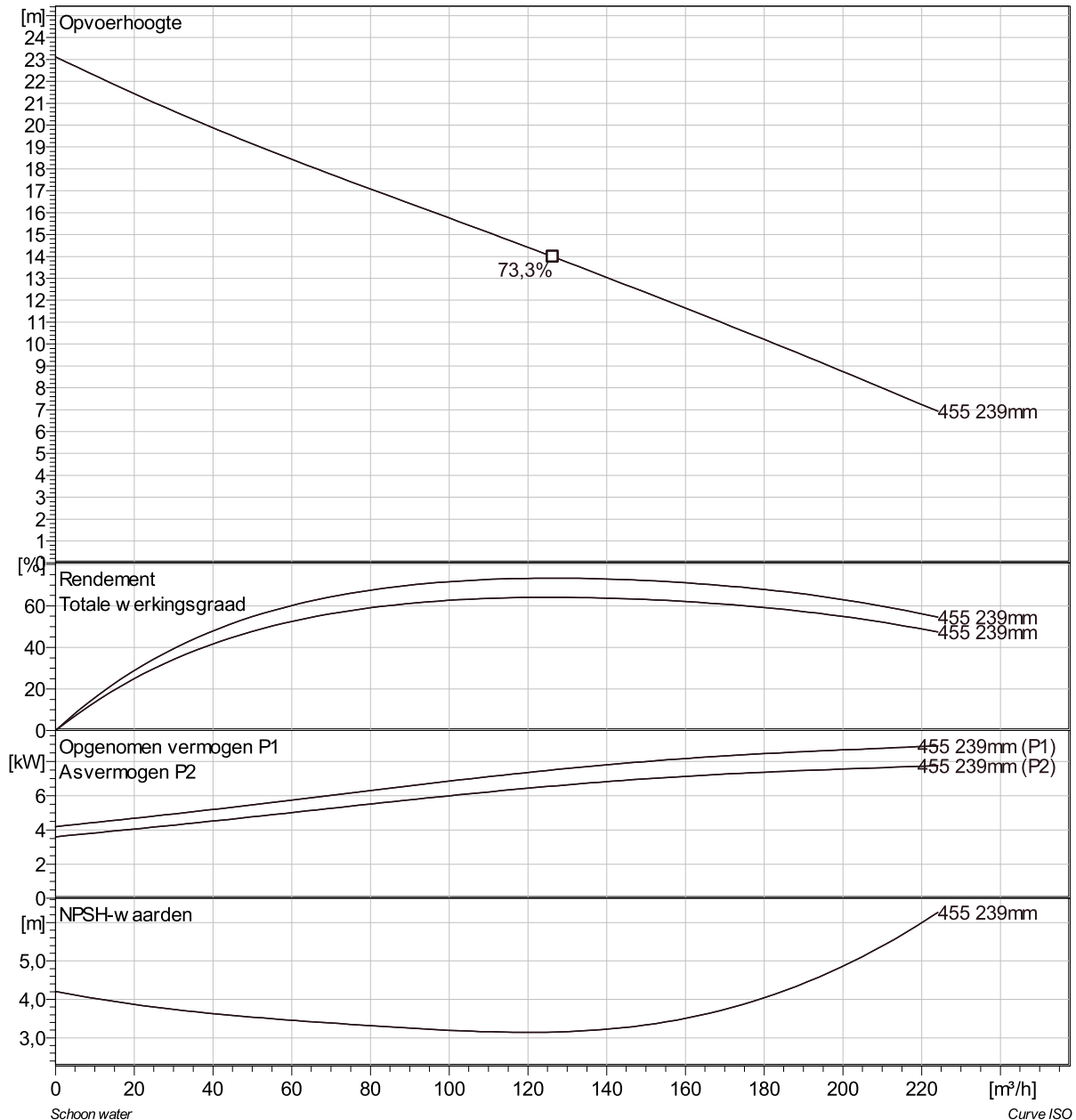

Project omschrijving	Projectnummer	Aangemaakt door:	Aangemaakt op 9/27/2018	Laatste wijziging
----------------------	---------------	------------------	----------------------------	-------------------

NP 3153 HT 3~ 455

VFD Analysis

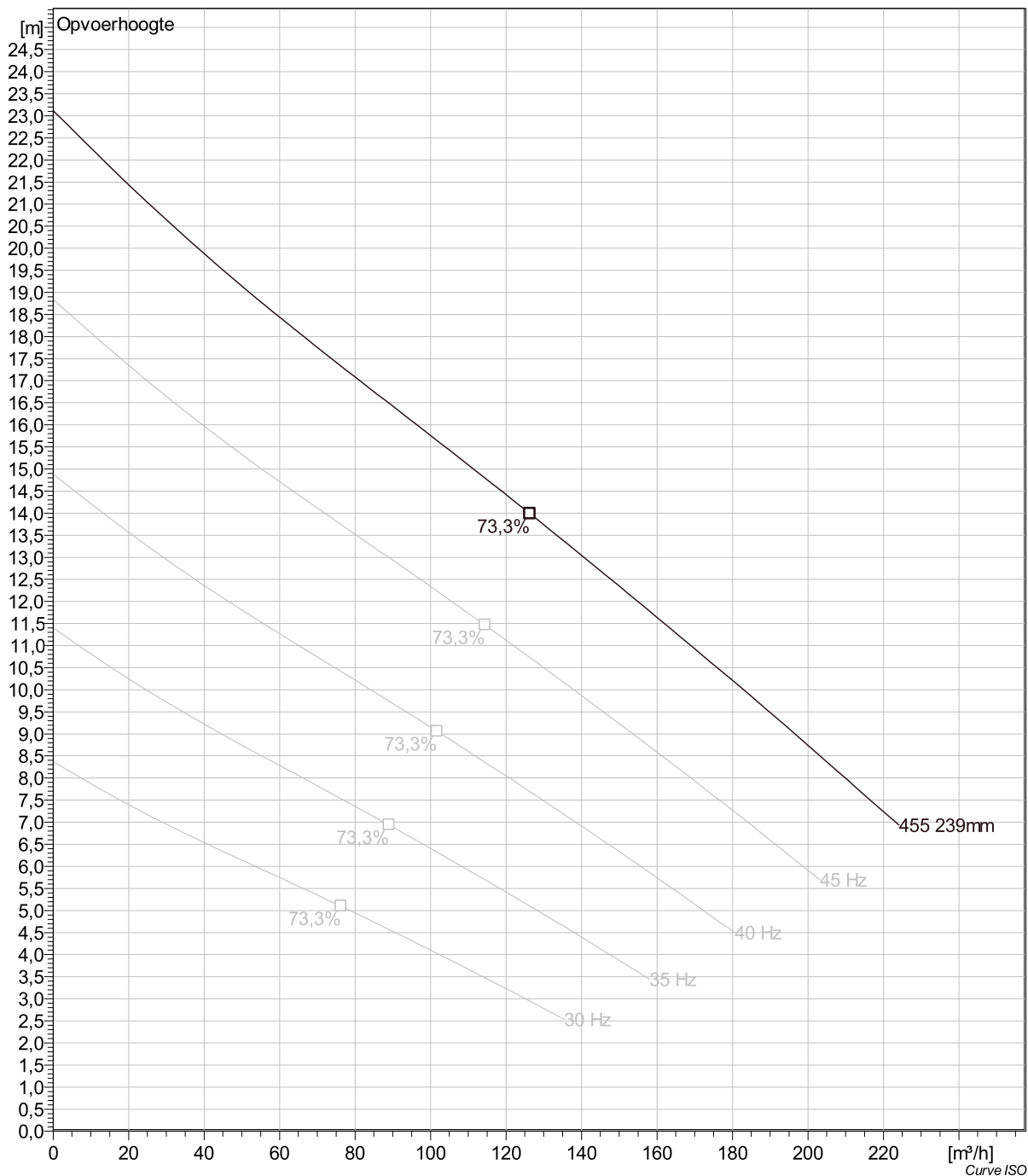

Project omschrijving	Projectnummer	Aangemaakt door:	Aangemaakt op 9/27/2018	Laatste wijziging
----------------------	---------------	------------------	----------------------------	-------------------

NP 3153 HT 3~ 455 Dimensional drawing

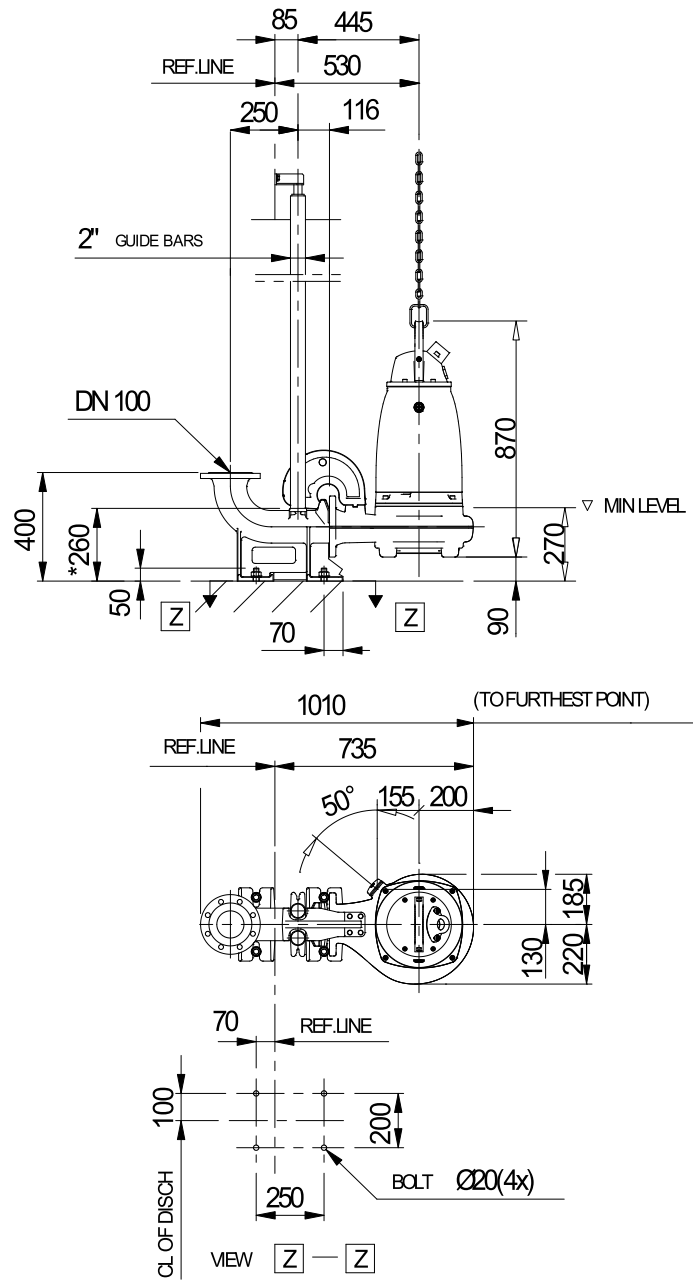

* DIMENSION TO ENDS OF GUIDE BARS

Weight

Dimensional dwg
NP,FP3153HT

Project omschrijving	Projectnummer	Aangemaakt door:	Aangemaakt op 9/27/2018	Laatste wijziging
----------------------	---------------	------------------	----------------------------	-------------------