

## NP 3153 LT 3~ 414 Technische specificaties

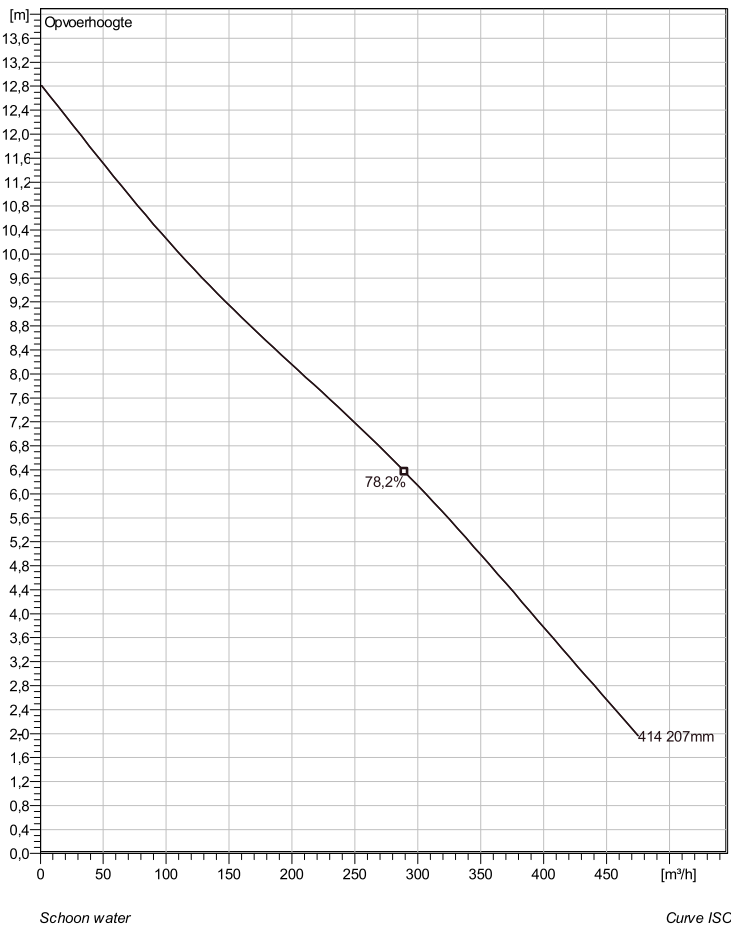

Note: Picture might not correspond to the current configuration.

### General

Dompelbare pompen voorzien van een verstoppingsongevoeilige N-waaiër. Geschikt voor afvalwater met grotere delen zoals rioolwater, regenwater en industriële afvalwater. Materiaal gietijzer.

### Impeller

Impeller material	Grey cast iron
Persaansluiting	200 mm
Diameter aanzuigzijde	200 mm
Impeller diameter	207 mm
Aantal bladen	2

### Motor

Motor #	N3153.181 21-15-4AA-W 7.5KW standaard
Stator variant	2
Frequentie	50 Hz
Nominale spanning	400 V
Aantal polen	4
Fasen	3~
Nominaal vermogen	7,5 kW
Toegekende stroom	16 A
Aanloopstroom	105 A
Nominaal toerental	1465 rpm
Vermogensfactor	
1/1 Load	0,77
3/4 Load	0,70
1/2 Load	0,56
Motor efficiency	
1/1 Load	87,0 %
3/4 Load	87,5 %
1/2 Load	86,0 %

### Soort installatie: Semi Permanent, Nat

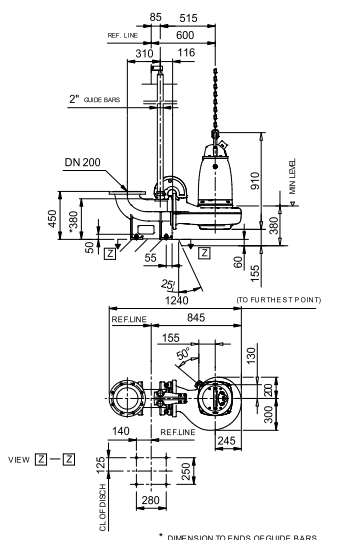

Note: 4 Poles Motor

Weight

Dimensional dwg  
NP-3153LT

Project omschrijving	Projectnummer	Aangemaakt door:	Aangemaakt op 9/27/2018	Laatste wijziging
----------------------	---------------	------------------	----------------------------	-------------------

## NP 3153 LT 3~ 414

### Karakteristiek

#### Pomp

Persaansluiting	200 mm
Diameter aanzuigzijde	200 mm
Impeller diameter	207 mm
Aantal bladen	2

#### Motor

Motor #	N3153.181 21-15-4AA-W 7.5KW
Stator variant	2
Frequentie	50 Hz
Nominale spanning	400 V
Aantal polen	4
Fasen	3~
Nominaal vermogen	7,5 kW
Toegekende stroom	16 A
Aanloopstroom	105 A
Nominaal toerental	1465 rpm

Vermogensfactor	
1/1 Load	0,77
3/4 Load	0,70
1/2 Load	0,56
Motor efficiency	
1/1 Load	87,0 %
3/4 Load	87,5 %
1/2 Load	86,0 %

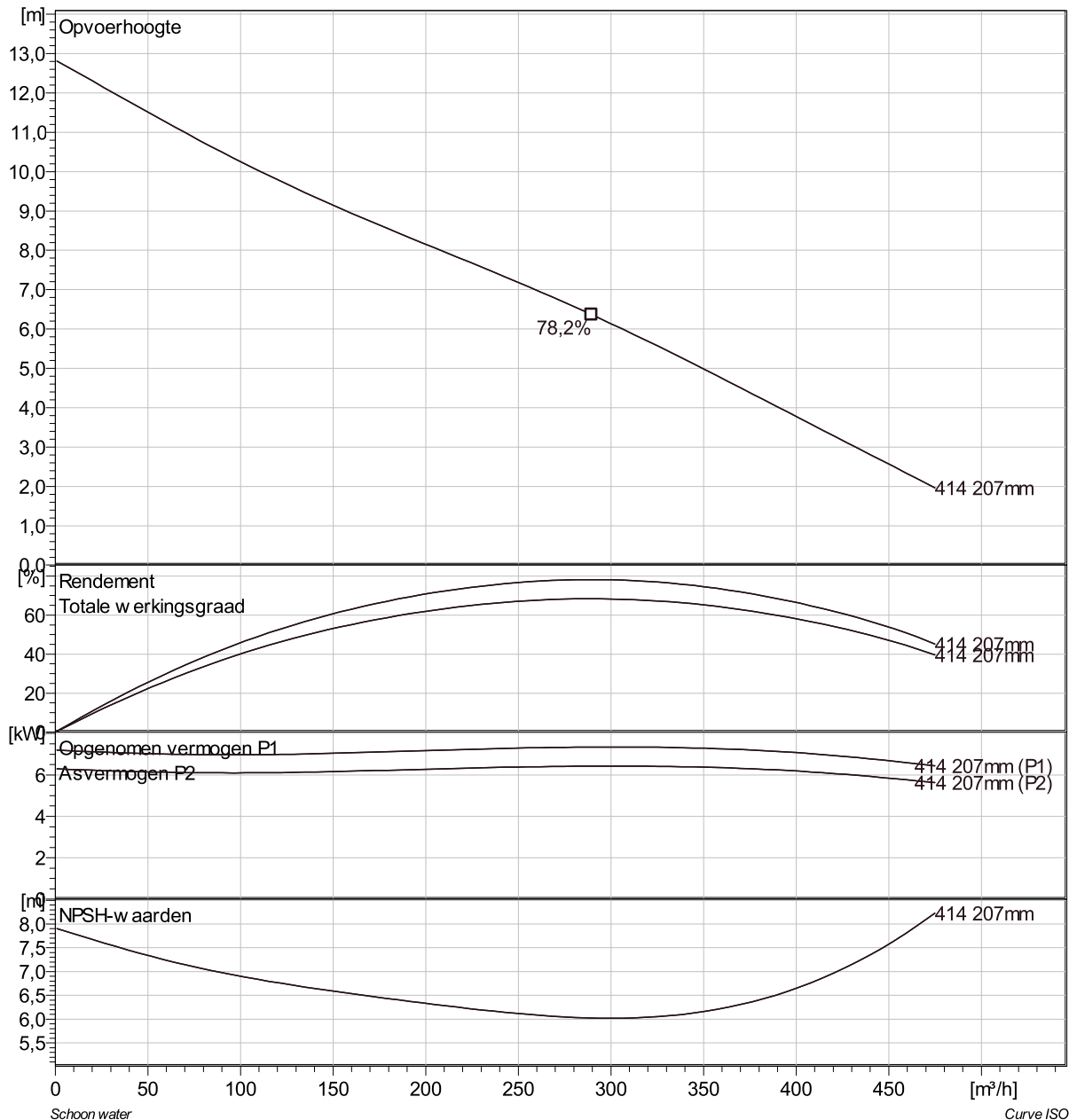

Project omschrijving	Projectnummer	Aangemaakt door:	Aangemaakt op 9/27/2018	Laatste wijziging
----------------------	---------------	------------------	----------------------------	-------------------

## NP 3153 LT 3~ 414 VFD Analysis

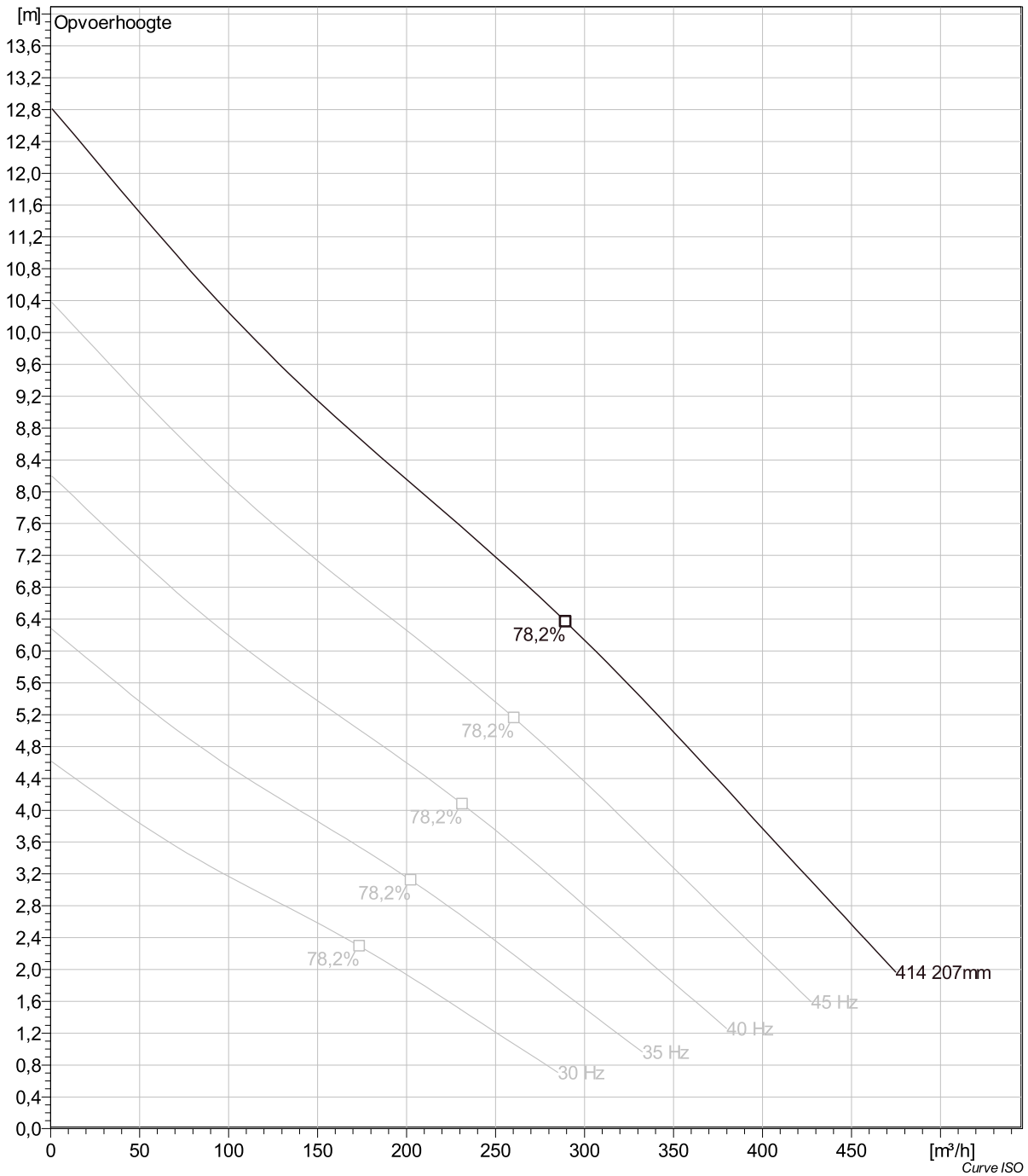

Project omschrijving	Projectnummer	Aangemaakt door:	Aangemaakt op 9/27/2018	Laatste wijziging
----------------------	---------------	------------------	----------------------------	-------------------

## NP 3153 LT 3~ 414 Dimensional drawing

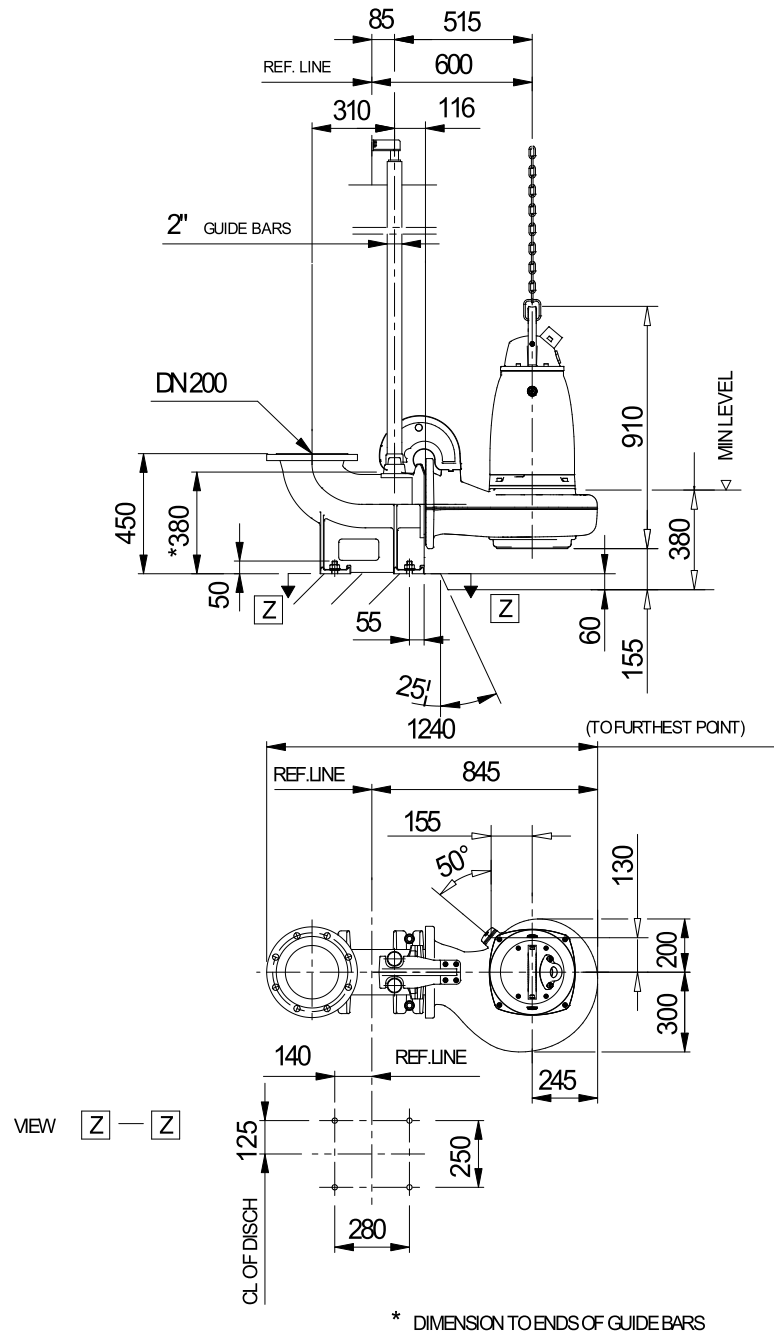

Note: 4 Poles Mtor

Weight

Dimensional dwg  
NP3153LT

Project omschrijving	Projectnummer	Aangemaakt door:	Aangemaakt op 9/27/2018	Laatste wijziging
----------------------	---------------	------------------	----------------------------	-------------------