

## NP 3153 MT 3~ 433

### Technische specificaties

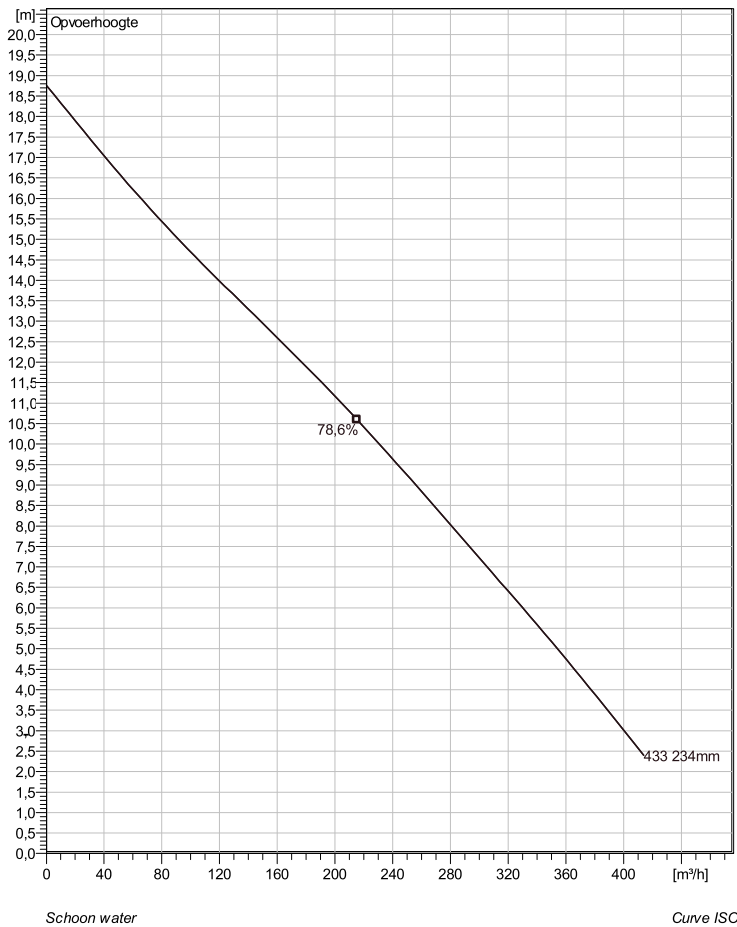

Note: Picture might not correspond to the current configuration.

#### General

Dompelbare pompen voorzien van een verstoppingsongevoeilige N-waaiër. Geschikt voor afvalwater met grotere delen zoals rioolwater, regenwater en industriële afvalwater. Materiaal gietijzer.

#### Impeller

Impeller material	Grey cast iron
Persaansluiting	150 mm
Diameter aanzuigzijde	150 mm
Impeller diameter	234 mm
Aantal bladen	2

#### Motor

Motor #	N3153.181 21-15-4AA-W 9KW standaard
Stator variant	2
Frequentie	50 Hz
Nominale spanning	230 V
Aantal polen	4
Fasen	3~
Nominaal vermogen	9 kW
Toegekende stroom	32 A
Aanloopstroom	181 A
Nominaal toerental	1460 rpm
Vermogensfactor	
1/1 Load	0,82
3/4 Load	0,75
1/2 Load	0,63
Motor efficiency	
1/1 Load	86,0 %
3/4 Load	87,0 %
1/2 Load	87,0 %

#### Soort installatie: Semi Permanent, Nat

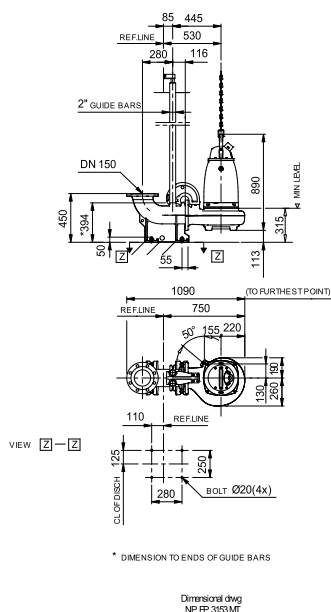

Project	Project ID	Created by	Created on 9/27/2018	Last update
---------	------------	------------	-------------------------	-------------

## NP 3153 MT 3~ 433

### Karakteristiek

#### Pomp

Persaansluiting	150 mm
Diameter aanzuigzijde	150 mm
Impeller diameter	234 mm
Aantal bladen	2

#### Motor

Motor #	N3153.181 21-15-4AA-W 9KW
Stator variant	2
Frequentie	50 Hz
Nominale spanning	230 V
Aantal polen	4
Fasen	3~
Nominaal vermogen	9 kW
Toegekende stroom	32 A
Aanloopstroom	181 A
Nominaal toerental	1460 rpm

Vermogensfactor	
1/1 Load	0,82
3/4 Load	0,75
1/2 Load	0,63
Motor efficiency	
1/1 Load	86,0 %
3/4 Load	87,0 %
1/2 Load	87,0 %

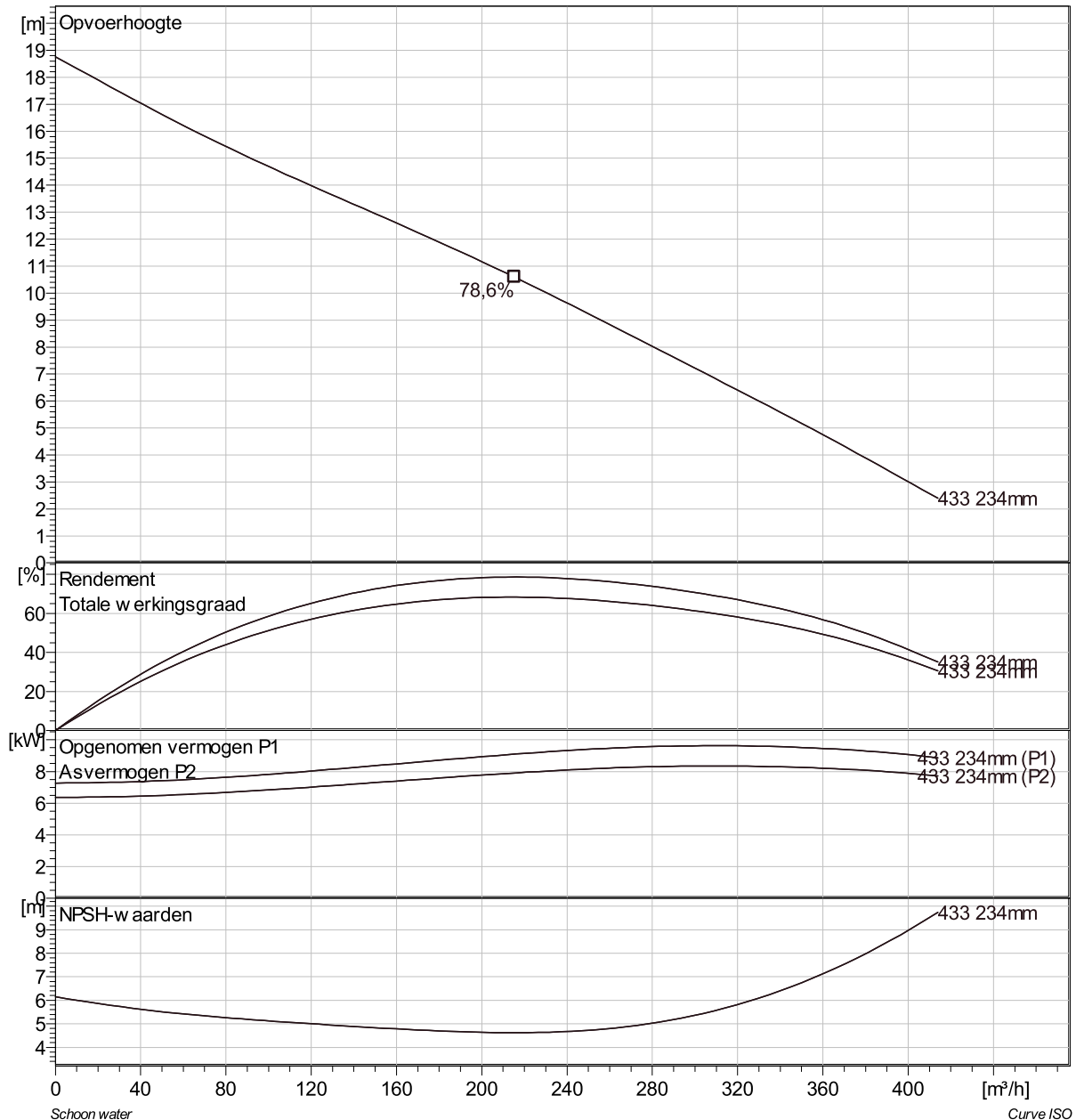

Project	Project ID	Created by	Created on 9/27/2018	Last update
---------	------------	------------	-------------------------	-------------

## NP 3153 MT 3~ 433 VFD Analysis

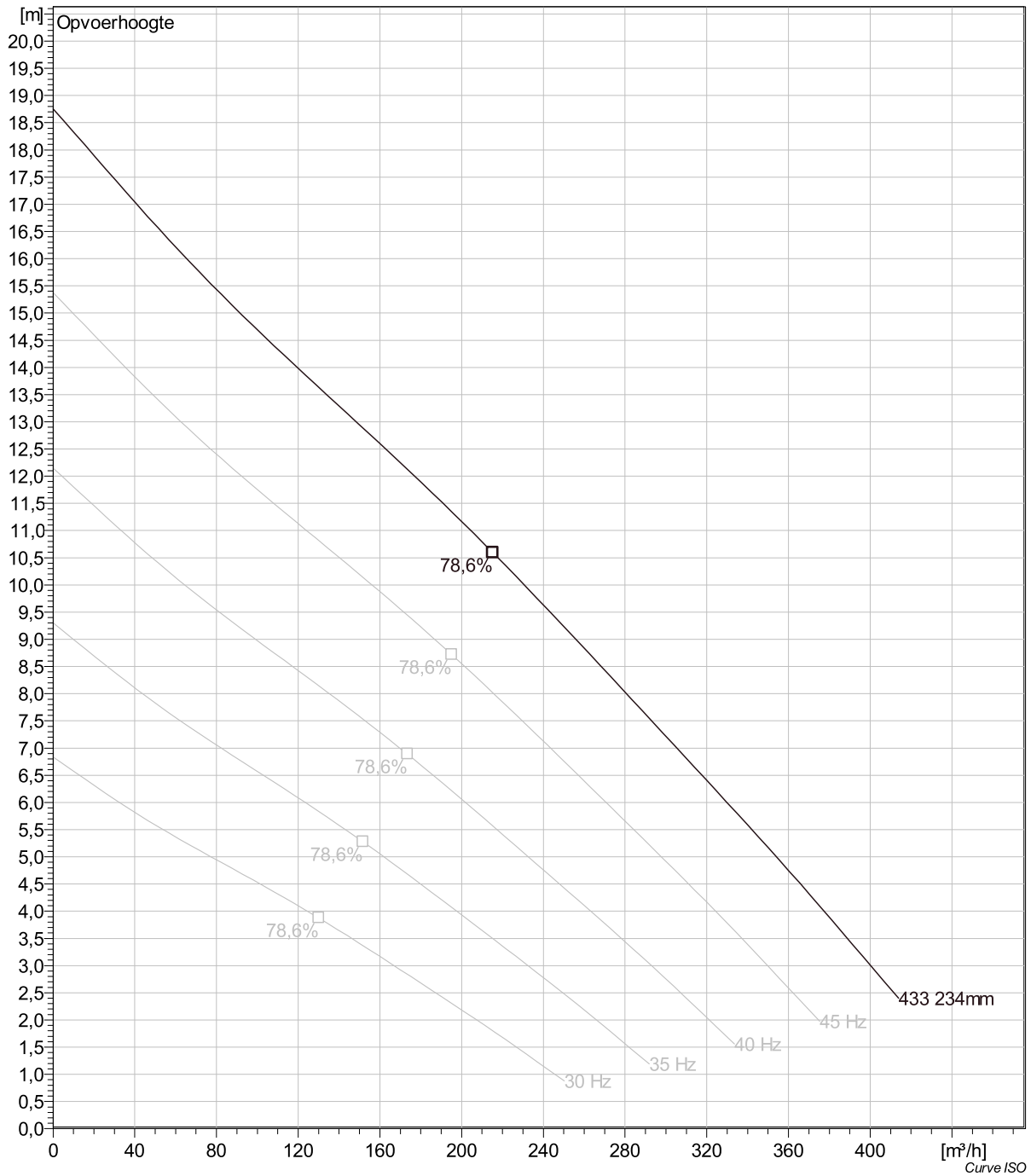

Project	Project ID	Created by	Created on	Last update
			9/27/2018	

## NP 3153 MT 3~ 433 Dimensional drawing

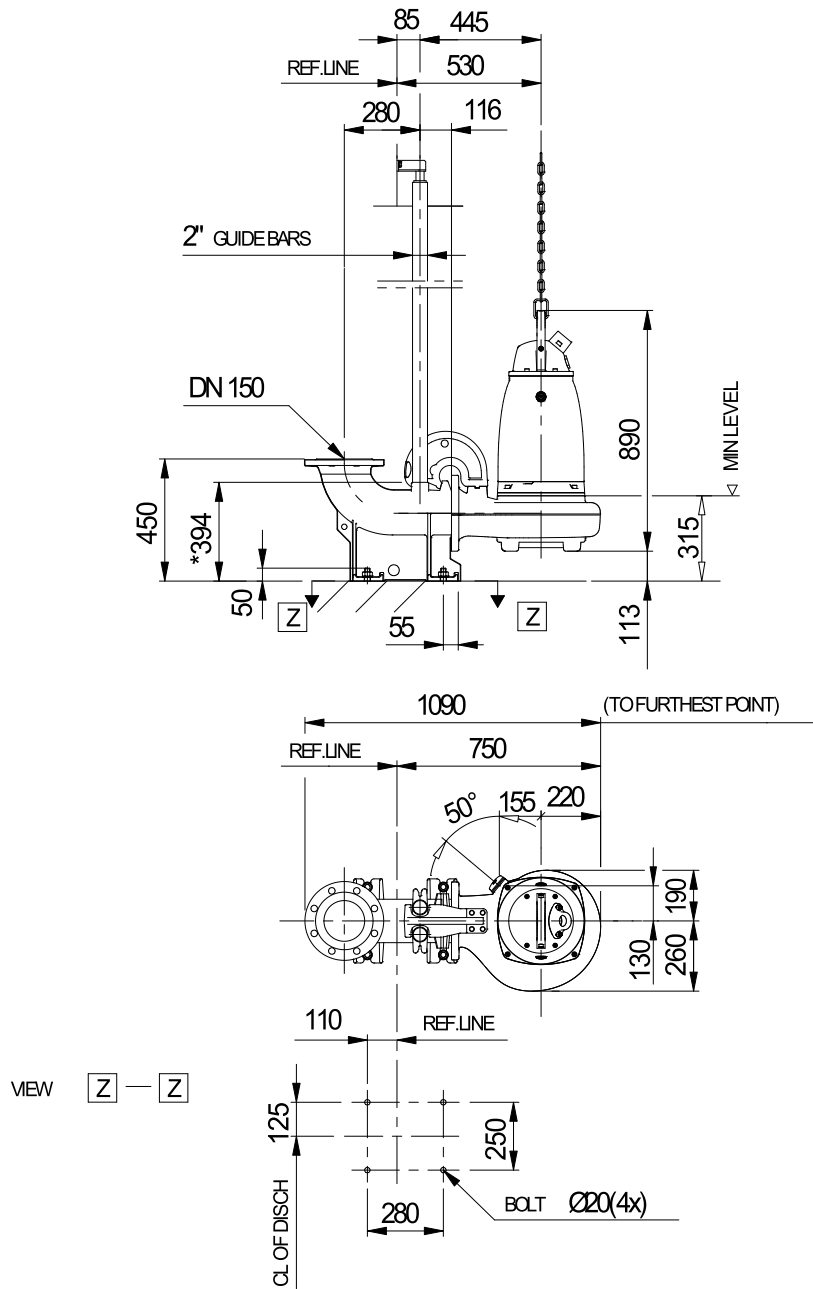

\* DIMENSION TO ENDS OF GUIDE BARS

Dimensional dwg  
NP,FP3153MT

Project	Project ID	Created by	Created on	Last update
			9/27/2018	