

## NP 3153 SH 3~ 270

### Technische specificaties

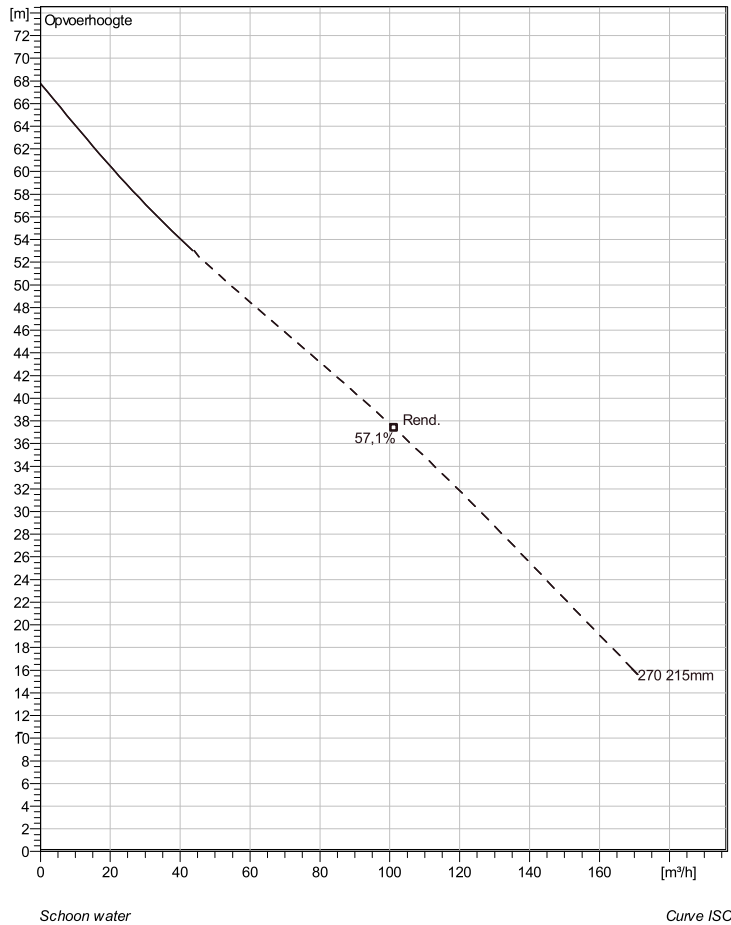

Note: Picture might not correspond to the current configuration.

#### General

Dompelbare pompen voorzien van verstopponsgevoelige N-waaiers. Geschikt voor afvalwater met grotere delen zoals rioolwater, regenwater en industriële afvalwater. Materiaal gietijzer.

#### Impeller

Impeller material	Grey cast iron
Persaansluiting	100 mm
Diameter aanzuigzijde	150 mm
Impeller diameter	215 mm
Aantal bladen	2

#### Motor

Motor #	N3153.181 21-18-2BB-W 15KW
Stator variant	2
Frequentie	50 Hz
Nominale spanning	230 V
Aantal polen	2
Fasen	3~
Nominaal vermogen	15 kW
Toegekende stroom	47 A
Aanloopstroom	370 A
Nominaal toerental	2915 rpm
Vermogensfactor	
1/1 Load	0,89
3/4 Load	0,84
1/2 Load	0,75
Rendement	
1/1 Load	90,0 %
3/4 Load	91,0 %
1/2 Load	91,0 %

#### Soort installatie: Semi Permanent, Nat

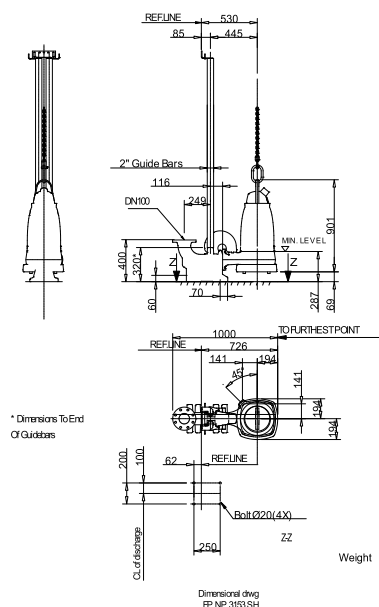

Project	Project ID	Created by	Created on	Last update
			9/27/2018	

## NP 3153 SH 3~ 270

### Karakteristiek

#### Pomp

Persaansluiting	100 mm
Diameter aanzuigzijde	150 mm
Impeller diameter	215 mm
Aantal bladen	2

#### Motor

Motor #	N3153.181 21-18-2BB-W 15KW
Stator variant	2
Frequentie	50 Hz
Nominale spanning	230 V
Aantal polen	2
Fasen	3~
Nominaal vermogen	15 kW
Toegekende stroom	47 A
Aanloopstroom	370 A
Nominaal toerental	2915 rpm

Vermogensfactor	
1/1 Load	0,89
3/4 Load	0,84
1/2 Load	0,75
Rendement	
1/1 Load	90,0 %
3/4 Load	91,0 %
1/2 Load	91,0 %

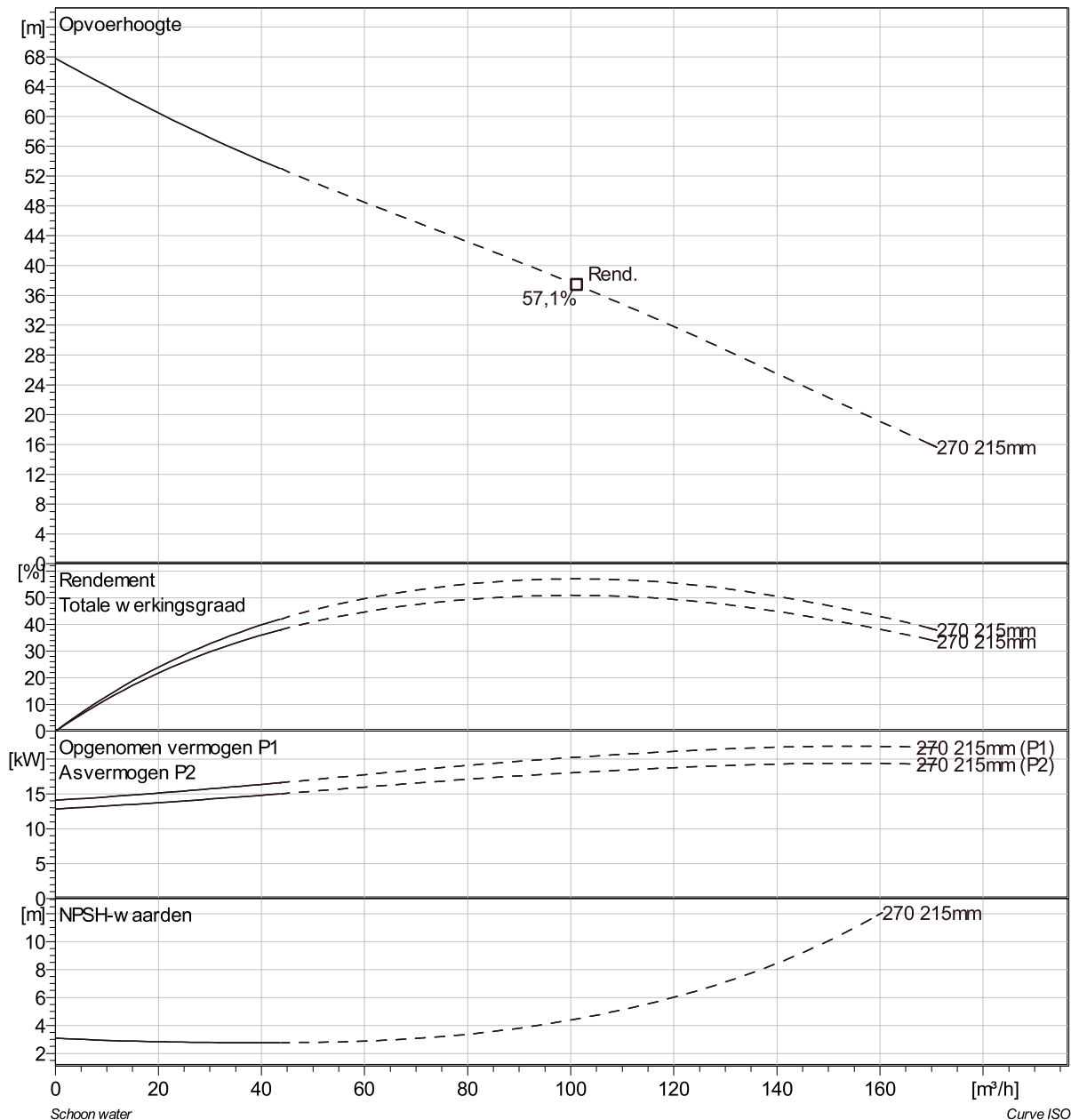

Project	Project ID	Created by	Created on 9/27/2018	Last update
---------	------------	------------	-------------------------	-------------

## NP 3153 SH 3~ 270 VFD Analysis

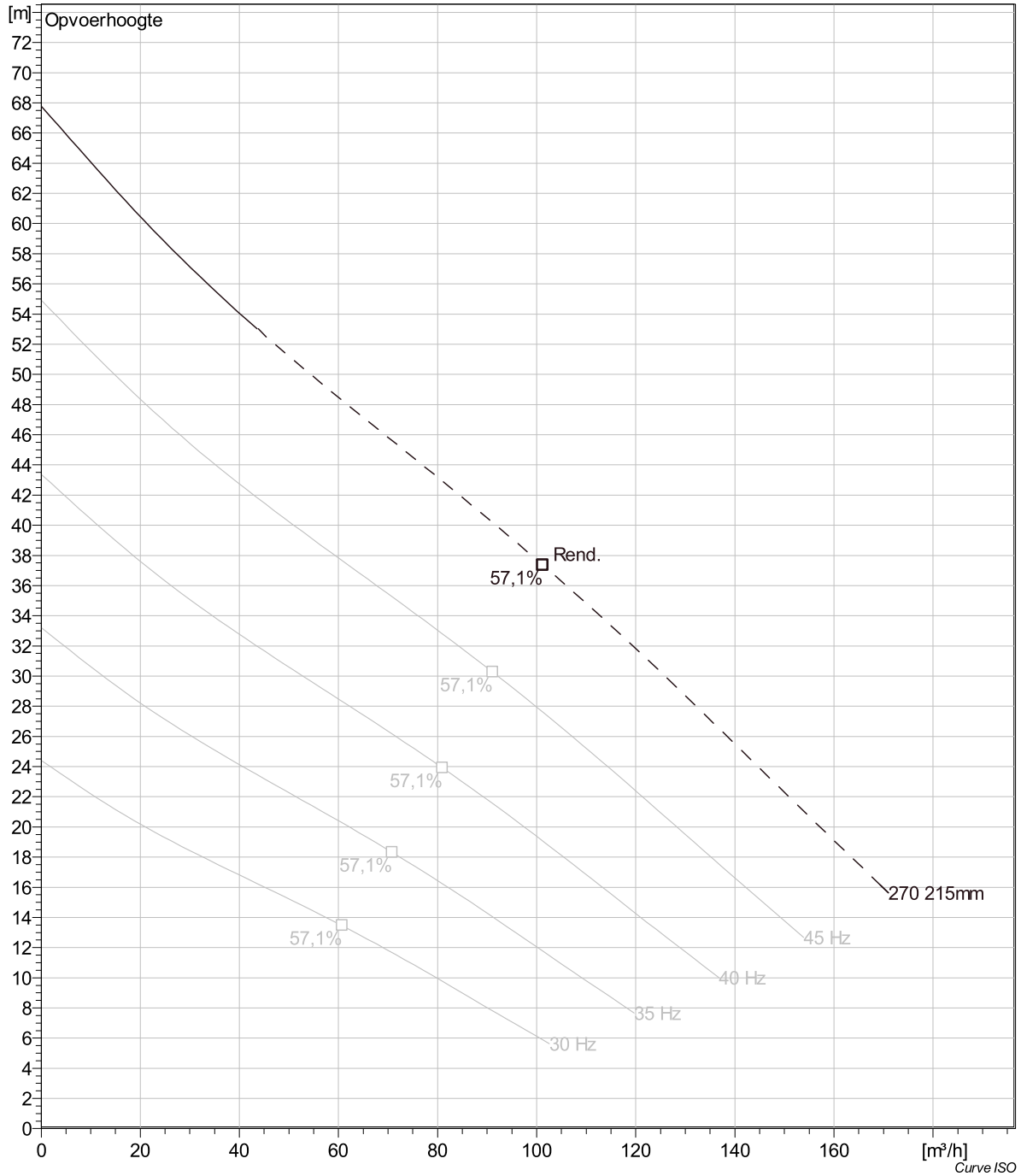

Project	Project ID	Created by	Created on	Last update
			9/27/2018	

## NP 3153 SH 3~ 270 Dimensional drawing

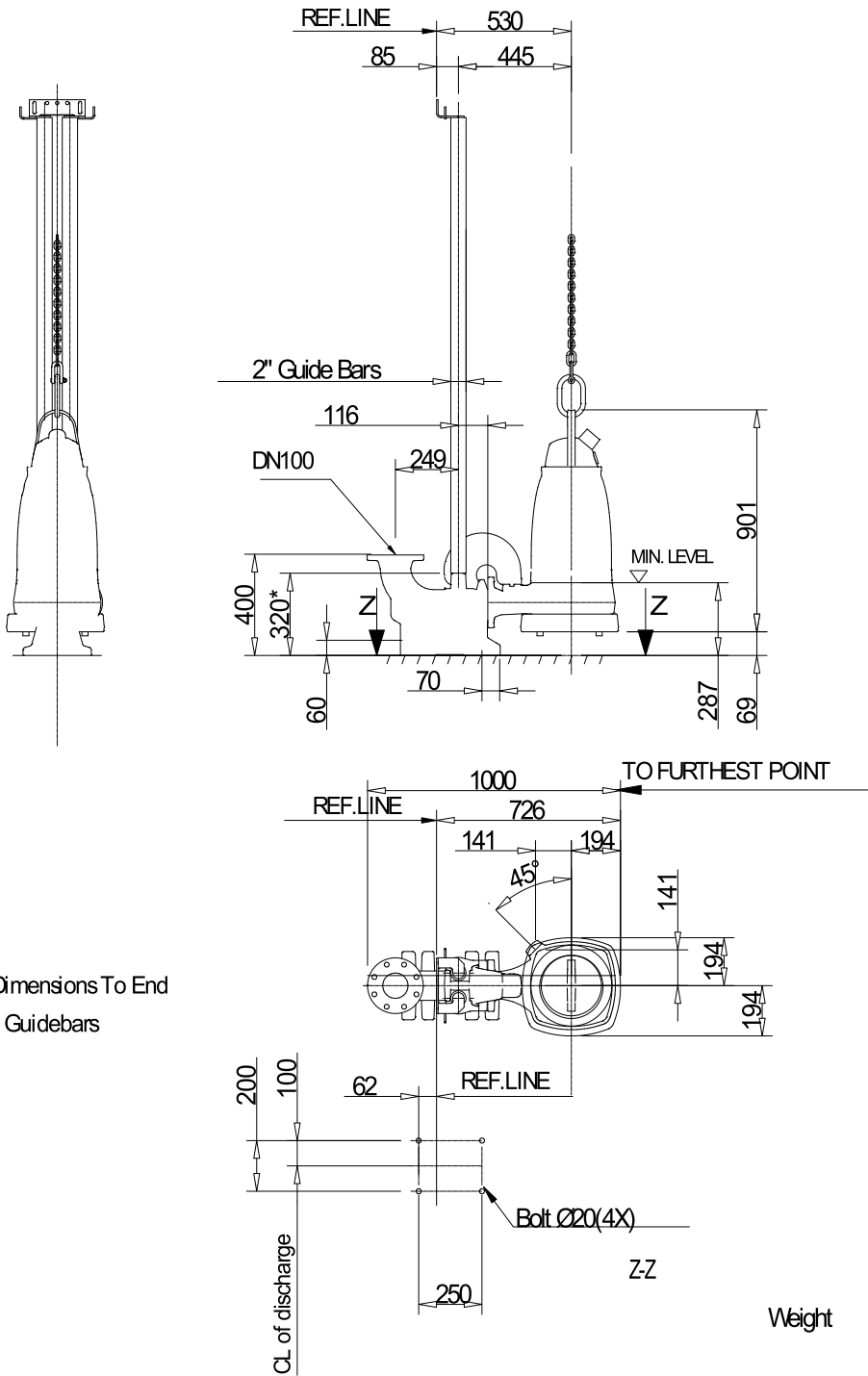

\* Dimensions To End Of Guidebars

Dimensional dwg  
FP, NP 3153 SH

Project	Project ID	Created by	Created on	Last update
			9/27/2018	