

NP 3153 SH 3~ 272

Technische specificaties

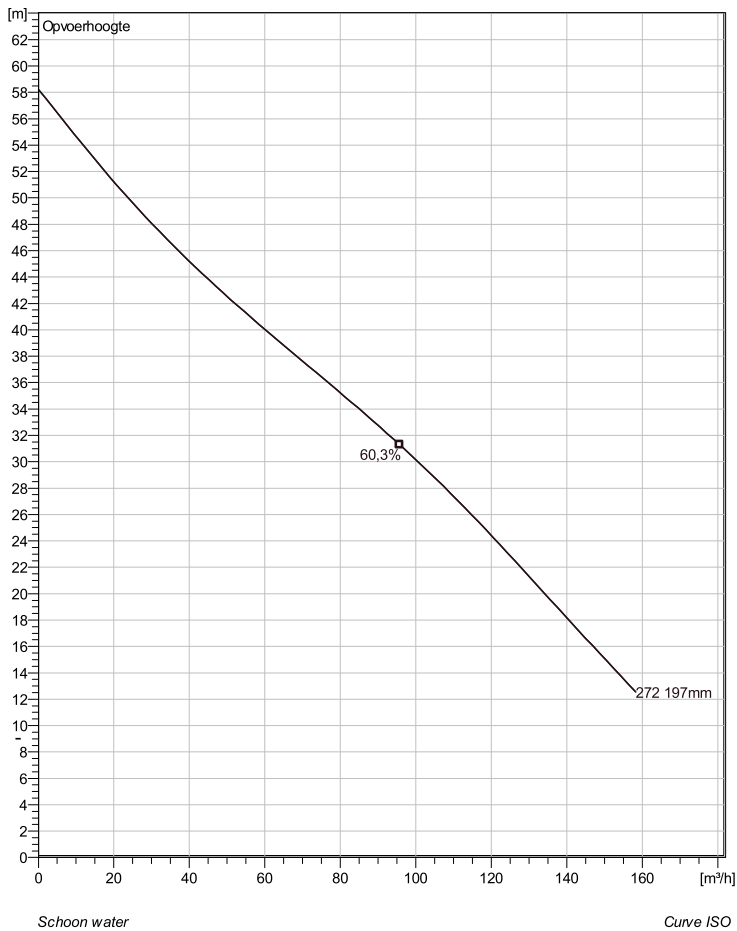

Note: Picture might not correspond to the current configuration.

General

Dompelbare pompen voorzien van verstopponsgevoelige N-waaiers. Geschikt voor afvalwater met grotere delen zoals rioolwater, regenwater en industriële afvalwater. Materiaal gietijzer.

Impeller

Impeller material	Grey cast iron
Persaansluiting	100 mm
Diameter aanzuigzijde	150 mm
Impeller diameter	197 mm
Aantal bladen	2

Motor

Motor #	N3153.181 21-18-2BB-W 15KW
Stator variant	2
Frequentie	50 Hz
Nominale spanning	230 V
Aantal polen	2
Fasen	3~
Nominaal vermogen	15 kW
Toegekende stroom	47 A
Aanloopstroom	370 A
Nominaal toerental	2915 rpm
Vermogensfactor	
1/1 Load	0,89
3/4 Load	0,84
1/2 Load	0,75
Rendement	
1/1 Load	90,0 %
3/4 Load	91,0 %
1/2 Load	91,0 %

Soort installatie: Semi Permanent, Nat

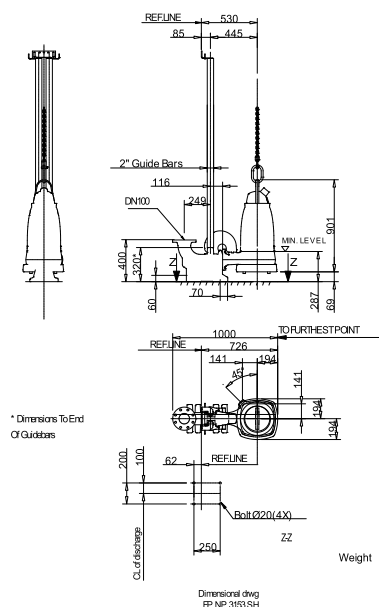

Project	Project ID	Created by	Created on 9/27/2018	Last update
---------	------------	------------	-------------------------	-------------

NP 3153 SH 3~ 272

Karakteristiek

Pomp

Persaansluiting	100 mm
Diameter aanzuigzijde	150 mm
Impeller diameter	197 mm
Aantal bladen	2

Motor

Motor #	N3153.181 21-18-2BB-W 15KW
Stator variant	2
Frequentie	50 Hz
Nominale spanning	230 V
Aantal polen	2
Fasen	3~
Nominaal vermogen	15 kW
Toegekende stroom	47 A
Aanloopstroom	370 A
Nominaal toerental	2915 rpm

Vermogensfactor	
1/1 Load	0,89
3/4 Load	0,84
1/2 Load	0,75
Rendement	
1/1 Load	90,0 %
3/4 Load	91,0 %
1/2 Load	91,0 %

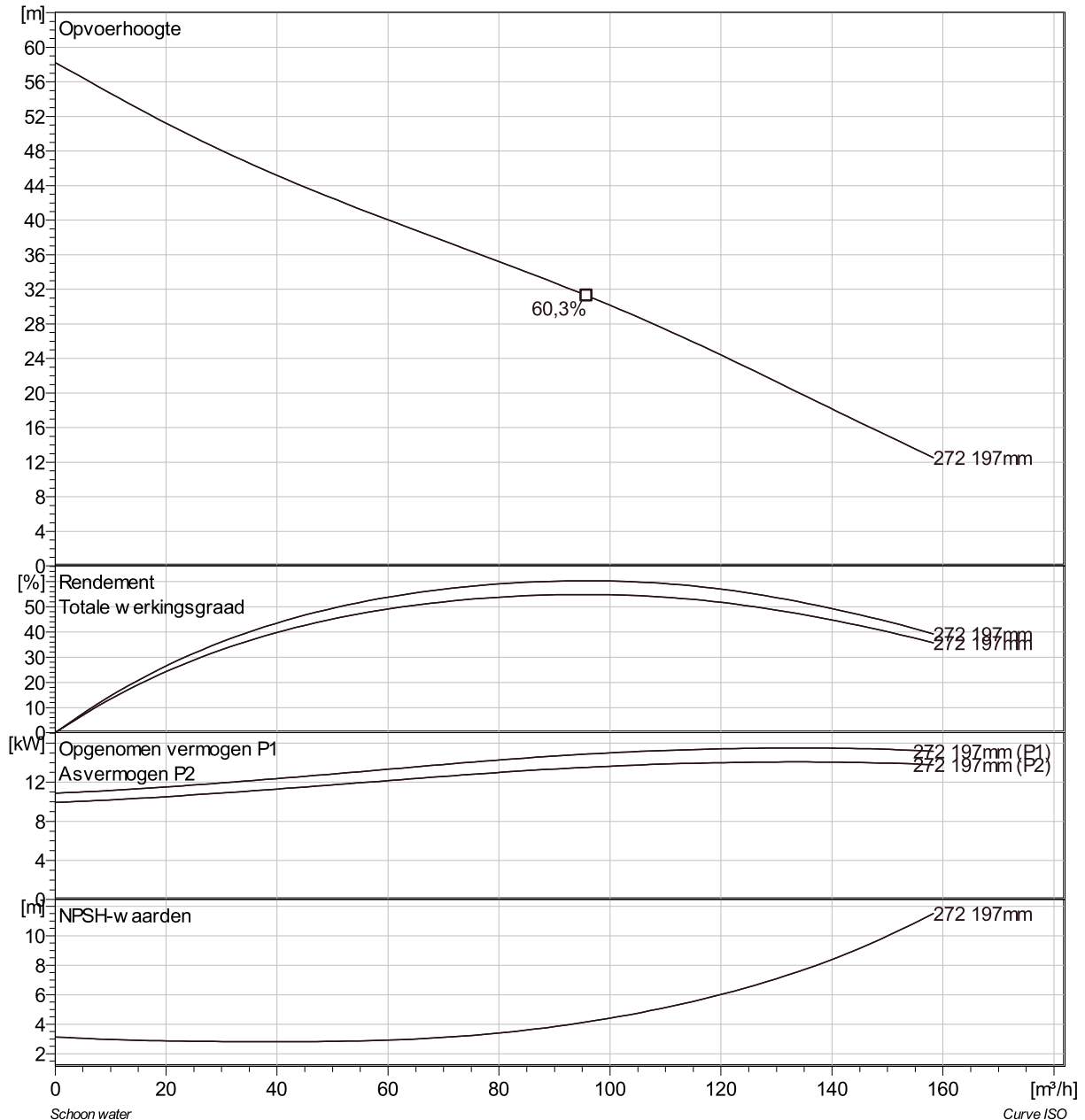

Project	Project ID	Created by	Created on 9/27/2018	Last update
---------	------------	------------	-------------------------	-------------

NP 3153 SH 3~ 272 VFD Analysis

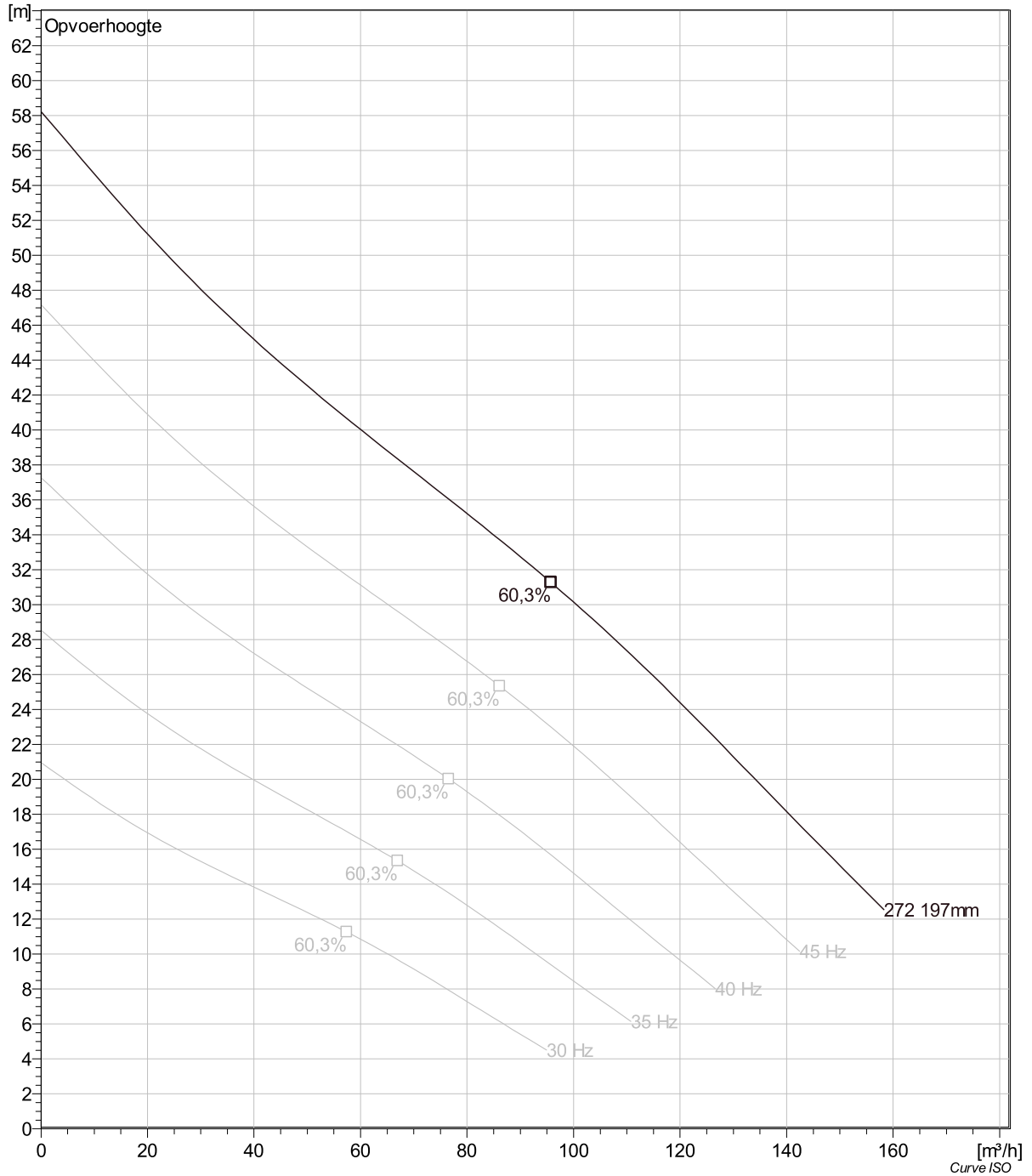

Project	Project ID	Created by	Created on	Last update
			9/27/2018	

NP 3153 SH 3~ 272 Dimensional drawing

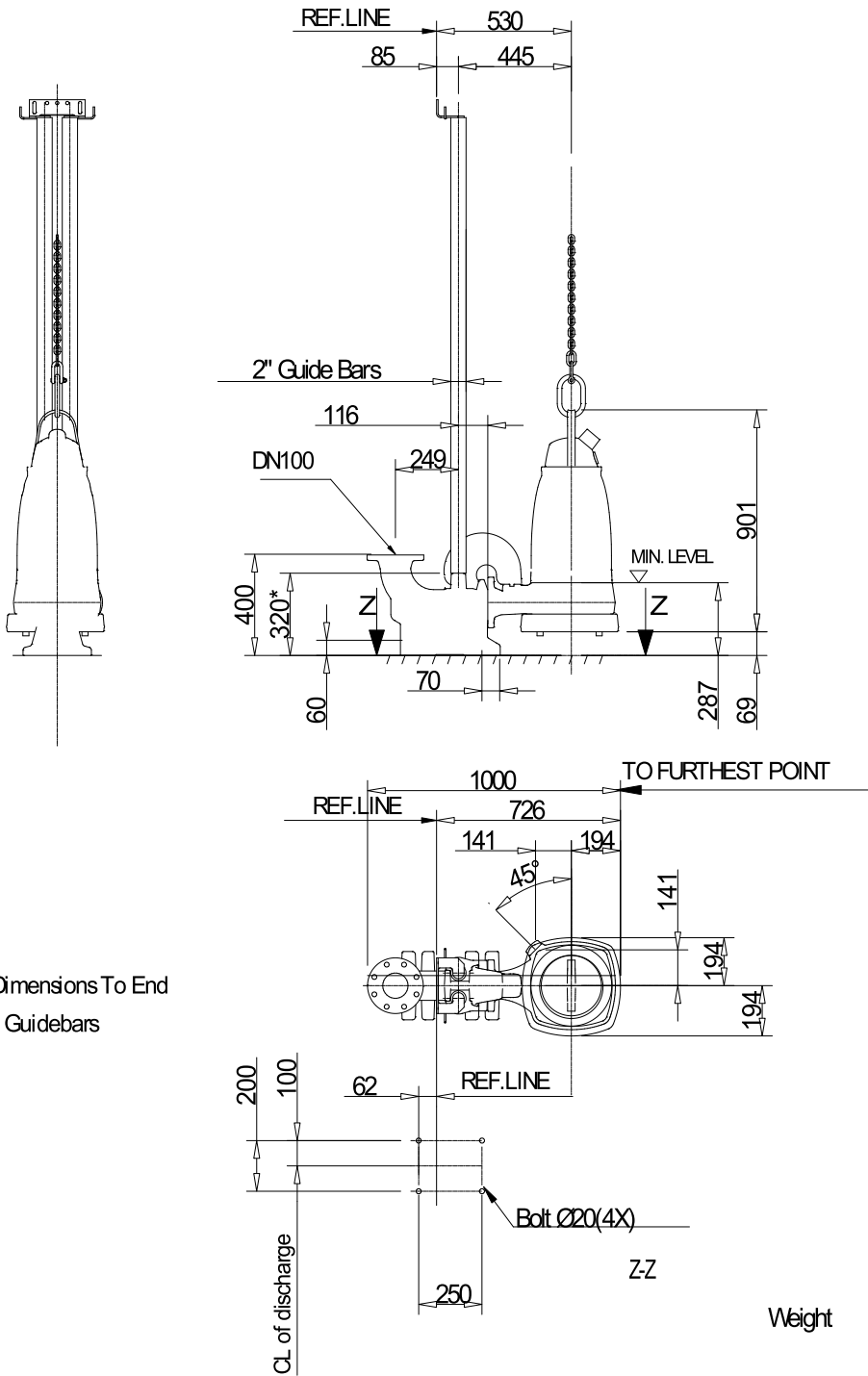

Dimensional dwg
FP, NP 3153 SH

Project	Project ID	Created by	Created on	Last update
			9/27/2018	