

NS 3153 HT 3~ 453 Technische specificaties

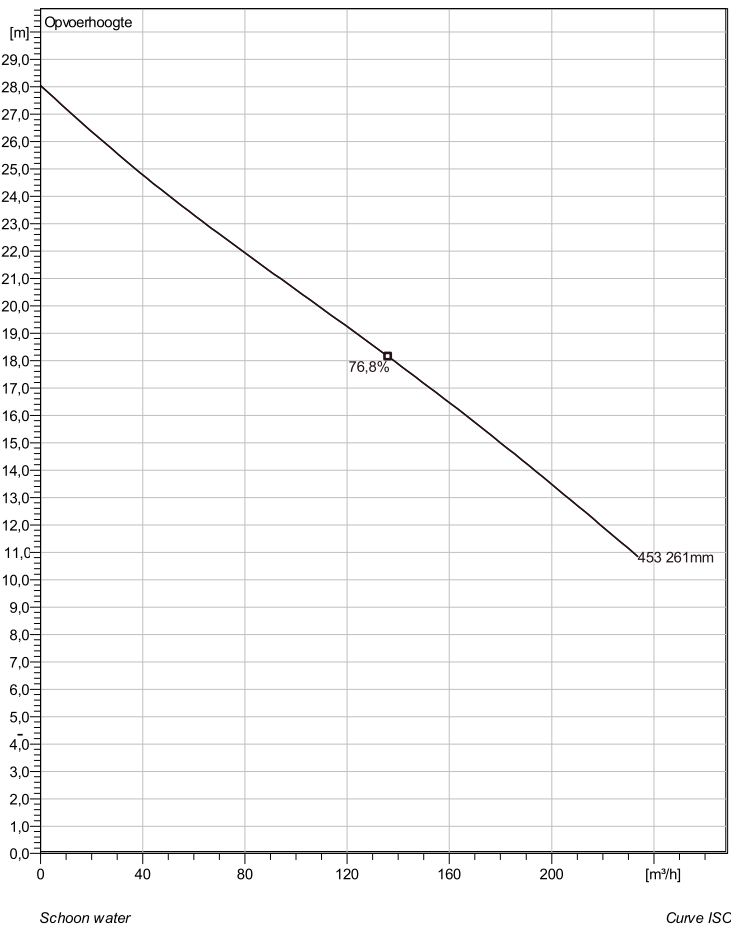

Note: Picture might not correspond to the current configuration.

General

Dompelbare pompen voorzien van een verstopponsgevoelige N-waaijer. Geschikt voor afvalwater met grotere delen zoals rioolwater, regenwater en industriële afvalwater. Materiaal gietijzer.

Impeller

Impeller materiaal	Grey cast iron
Persaansluiting	100 mm
Diameter aanzuigzijde	100 mm
Impeller diameter	261 mm
Aantal bladen	2

Motor

Motor #	N3153.181 21-18-4AA-W 13.5KW standaard
Stator variant	2
Frequentie	50 Hz
Nominale spanning	230 V
Aantal polen	4
Fasen	3~
Nominaal vermogen	13,5 kW
Toegekende stroom	47 A
Aanloopstroom	250 A
Nominaal toerental	1455 rpm
Vermogensfactor	
1/1 Load	0,84
3/4 Load	0,79
1/2 Load	0,68
Motor efficiency	
1/1 Load	86,5 %
3/4 Load	88,0 %
1/2 Load	88,5 %

Soort installatie: Semi permanent, Nat

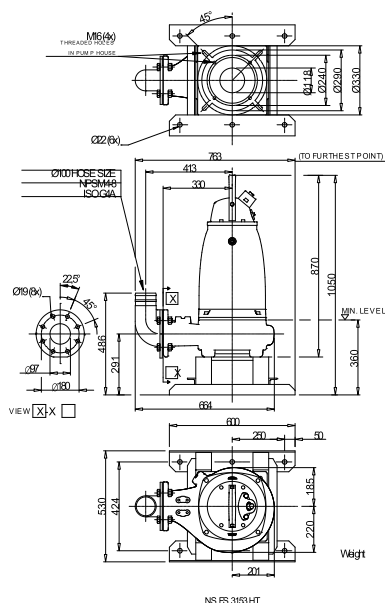

Project	Project ID	Created by	Created on 10/5/2018	Last update
---------	------------	------------	-------------------------	-------------

NS 3153 HT 3~ 453

Karakteristiek

Pomp

Persaansluiting	100 mm
Diameter aanzuigzijde	100 mm
Impeller diameter	261 mm
Aantal bladen	2

Motor

Motor #	N3153.181 21-18-4AA-W 13.5KW
Stator variant	2
Frequentie	50 Hz
Nominale spanning	230 V
Aantal polen	4
Fasen	3~
Nominaal vermogen	13,5 kW
Toegekende stroom	47 A
Aanloopstroom	250 A
Nominaal toerental	1455 rpm

Vermogensfactor	
1/1 Load	0,84
3/4 Load	0,79
1/2 Load	0,68
Motor efficiency	
1/1 Load	86,5 %
3/4 Load	88,0 %
1/2 Load	88,5 %

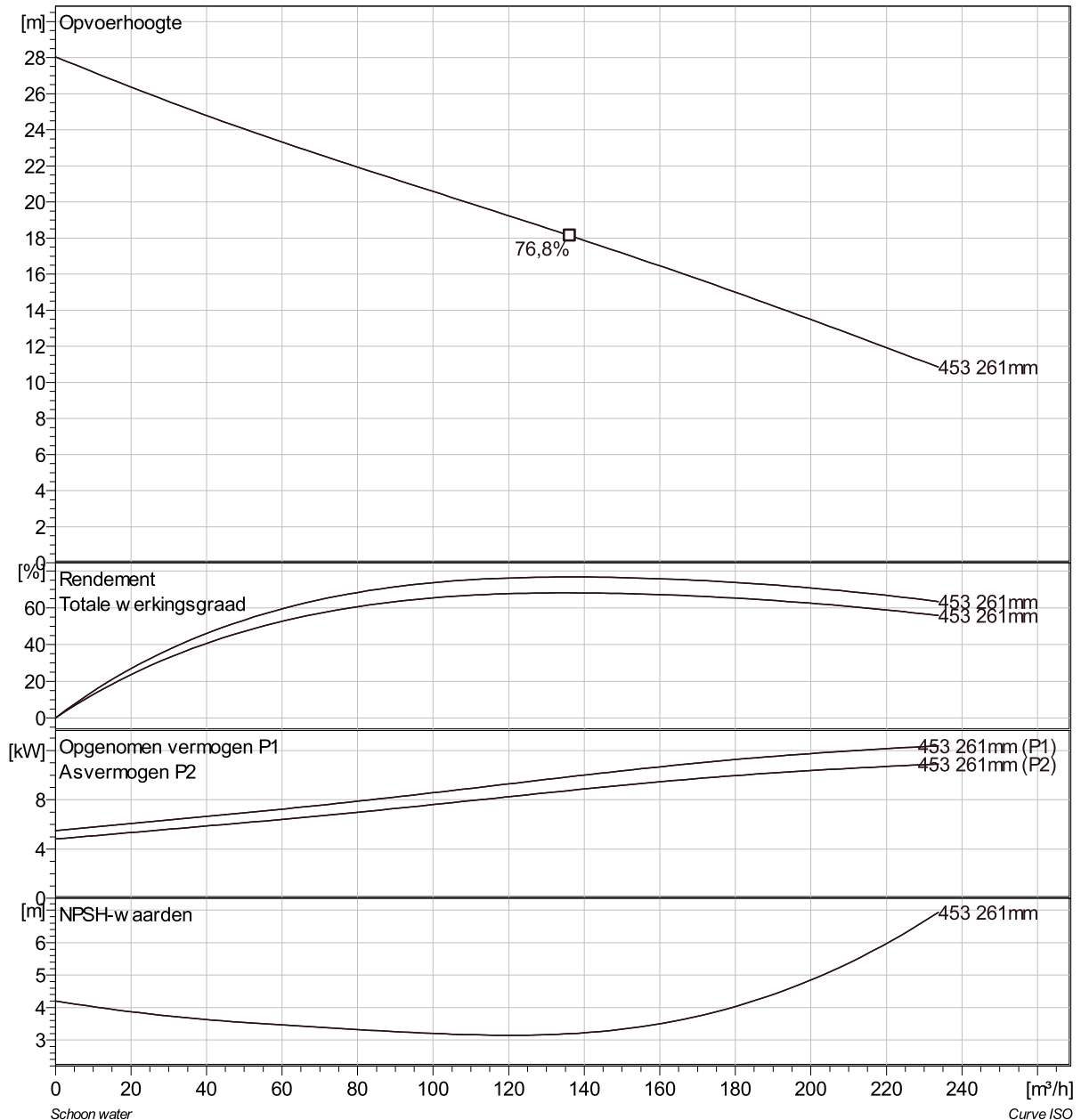

Project	Project ID	Created by	Created on 10/5/2018	Last update
---------	------------	------------	-------------------------	-------------

NS 3153 HT 3~ 453 VFD Analysis

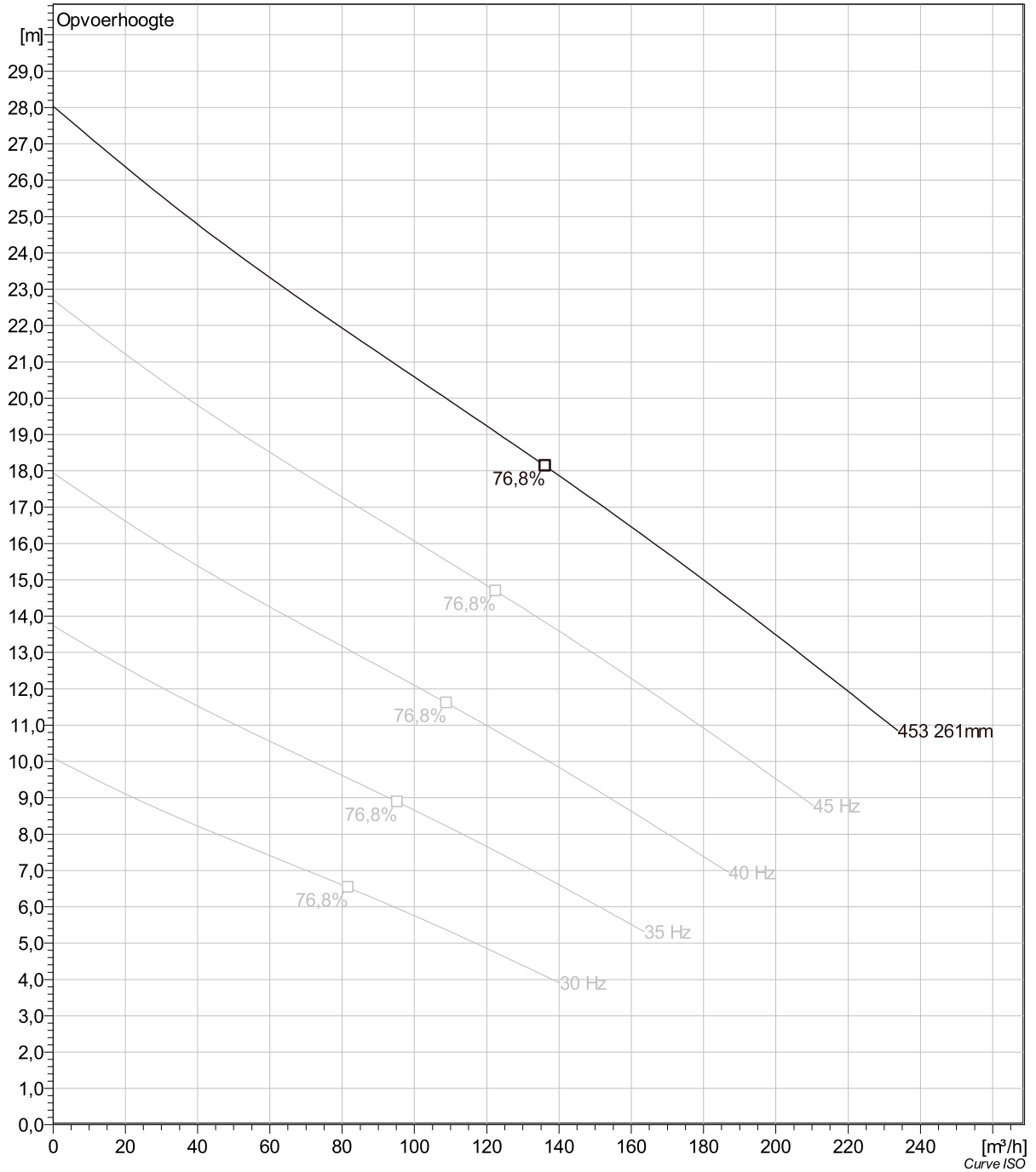

Project	Project ID	Created by	Created on	Last update
			10/5/2018	

NS 3153 HT 3~ 453 Dimensional drawing

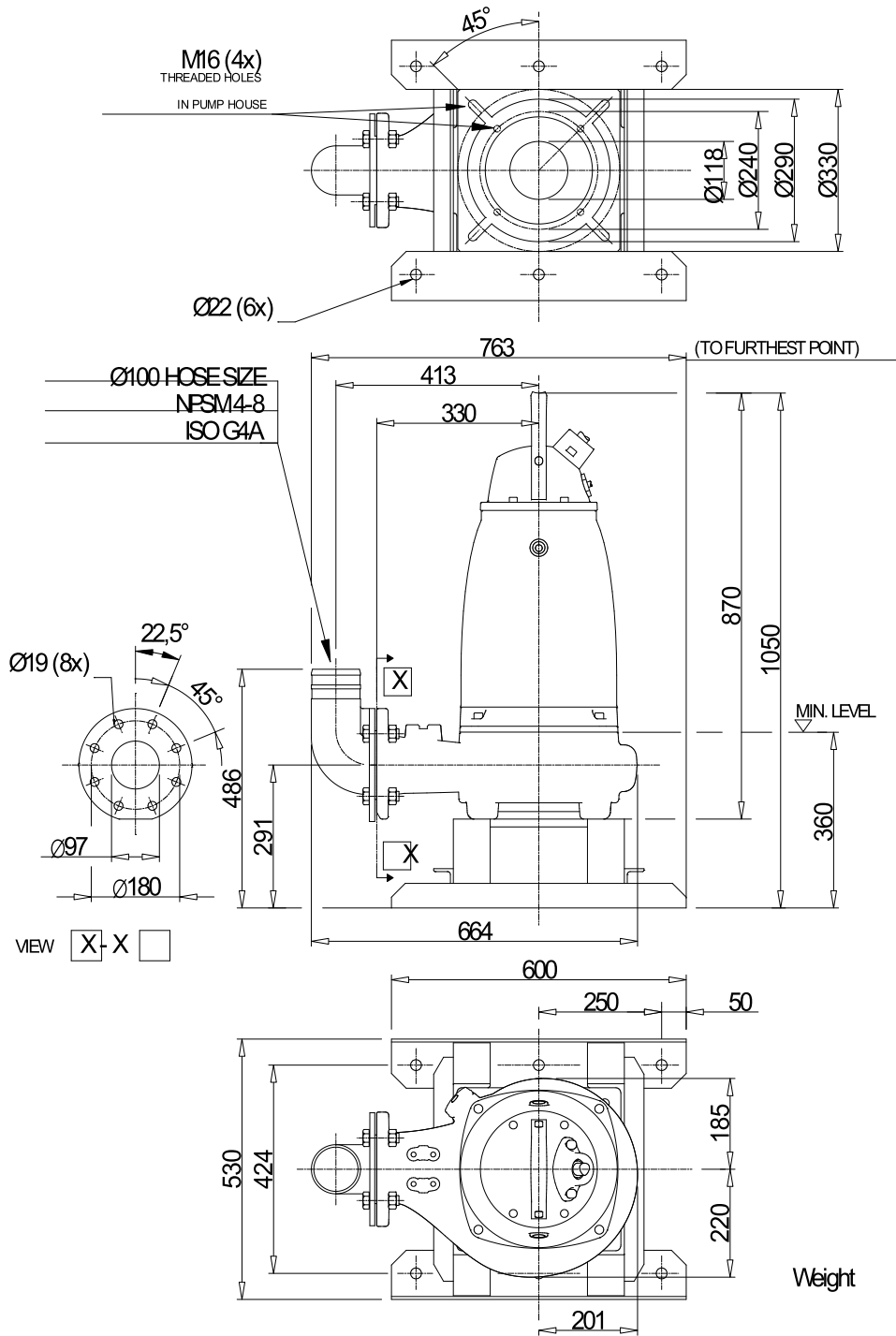

NS,FS 3153 HT

Project	Project ID	Created by	Created on	Last update
			10/5/2018	