

NS 3153 LT 3~ 412 Technische specificaties

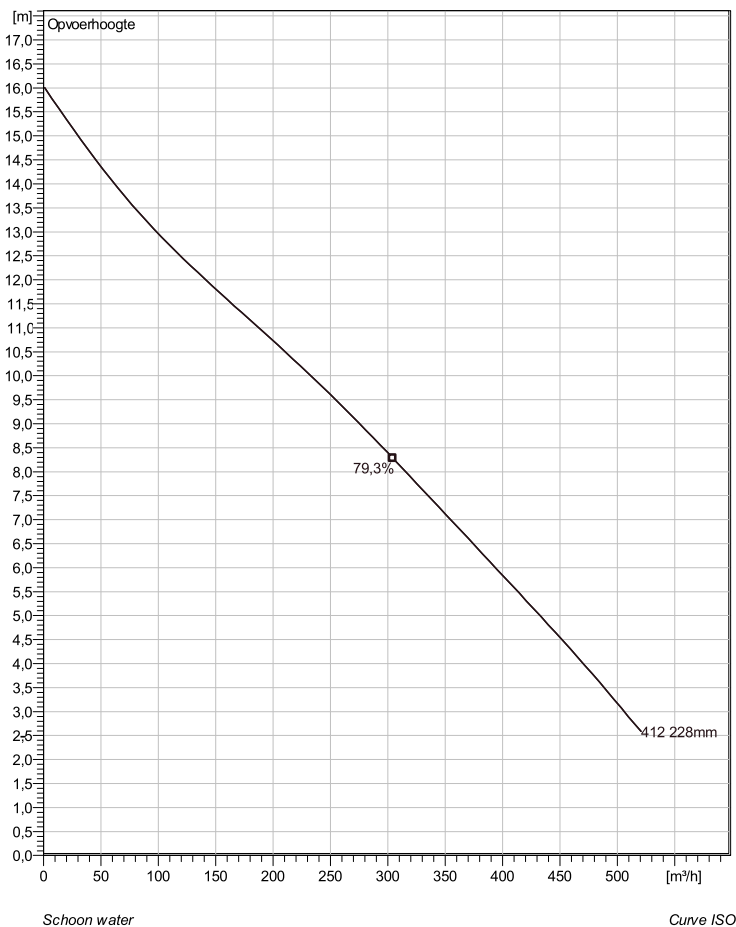

Note: Picture might not correspond to the current configuration.

General

Dompelbare pompen voorzien van een verstopingsongevoeilige N-waaiër. Geschikt voor afvalwater met grotere delen zoals rioolwater, regenwater en industriële afvalwater. Materiaal gietijzer.

Impeller

Impeller material	Grey cast iron
Persaansluiting	200 mm
Diameter aanzuigzijde	200 mm
Impeller diameter	228 mm
Aantal bladen	2

Motor

Motor #	N3153.181 21-15-4AA-W 9KW standaard
Stator variant	2
Frequentie	50 Hz
Nominale spanning	230 V
Aantal polen	4
Fasen	3~
Nominaal vermogen	9 kW
Toegekende stroom	32 A
Aanloopstroom	181 A
Nominaal toerental	1460 rpm
Vermogensfactor	
1/1 Load	0,82
3/4 Load	0,75
1/2 Load	0,63
Motor efficiency	
1/1 Load	86,0 %
3/4 Load	87,0 %
1/2 Load	87,0 %

Soort installatie: Semi permanent, Nat

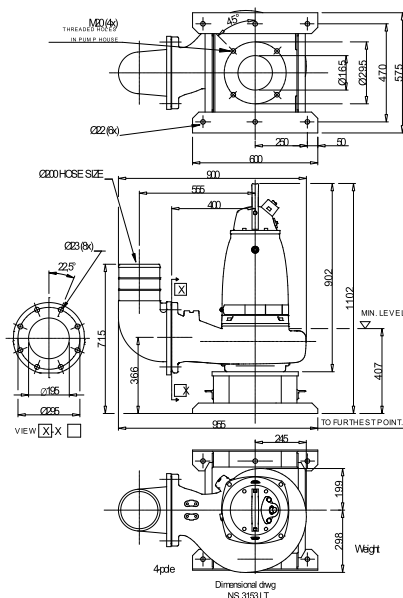

Project	Project ID	Created by	Created on 10/5/2018	Last update
---------	------------	------------	-------------------------	-------------

NS 3153 LT 3~ 412

Karakteristiek

Pomp

Persaansluiting	200 mm
Diameter aanzuigzijde	200 mm
Impeller diameter	228 mm
Aantal bladen	2

Motor

Motor #	N3153.181 21-15-4AA-W 9KW
Stator variant	2
Frequentie	50 Hz
Nominale spanning	230 V
Aantal polen	4
Fasen	3~
Nominaal vermogen	9 kW
Toegekende stroom	32 A
Aanloopstroom	181 A
Nominaal toerental	1460 rpm

Vermogensfactor	
1/1 Load	0,82
3/4 Load	0,75
1/2 Load	0,63
Motor efficiency	
1/1 Load	86,0 %
3/4 Load	87,0 %
1/2 Load	87,0 %

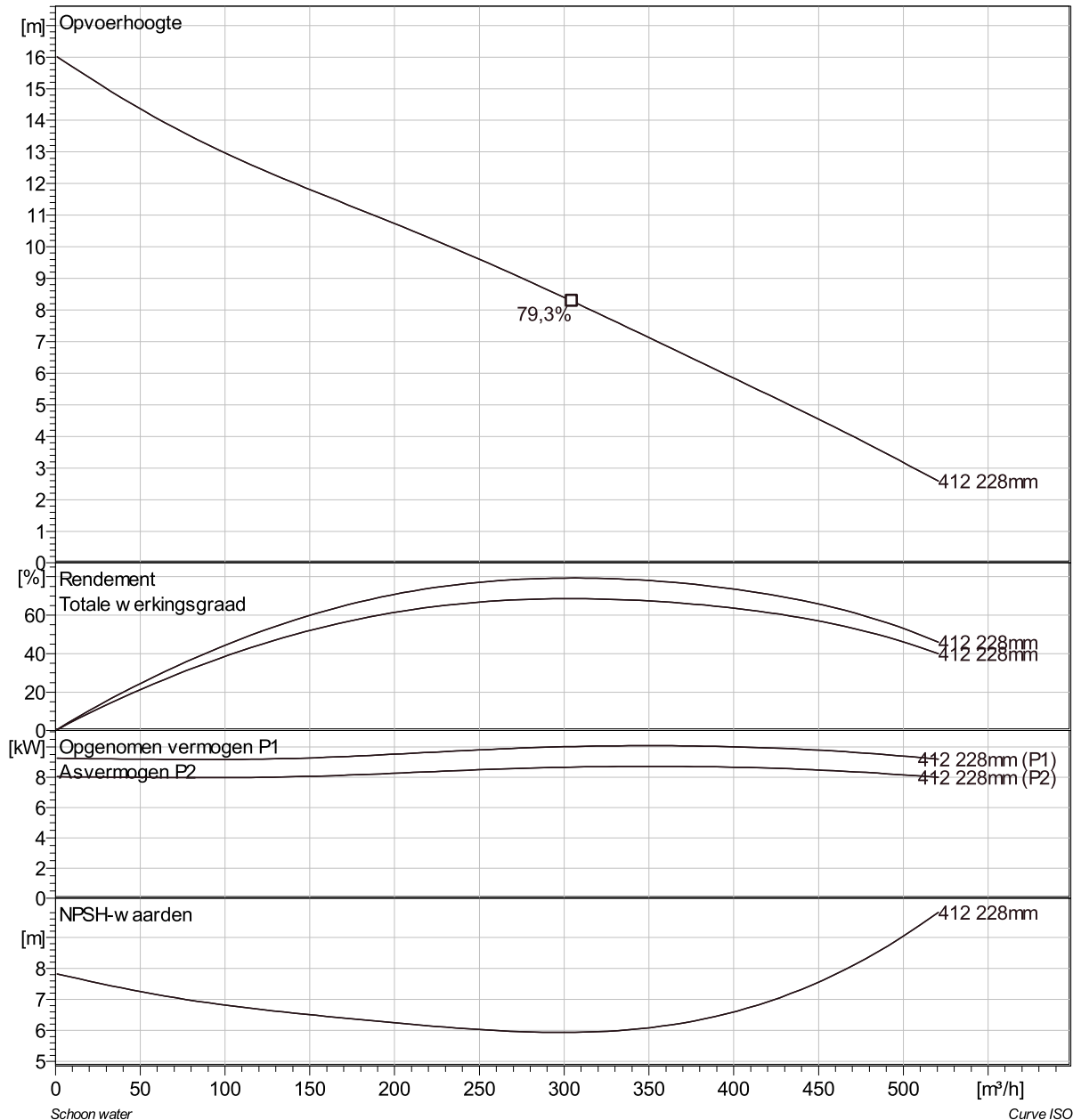

Project	Project ID	Created by	Created on 10/5/2018	Last update
---------	------------	------------	-------------------------	-------------

NS 3153 LT 3~ 412 VFD Analysis

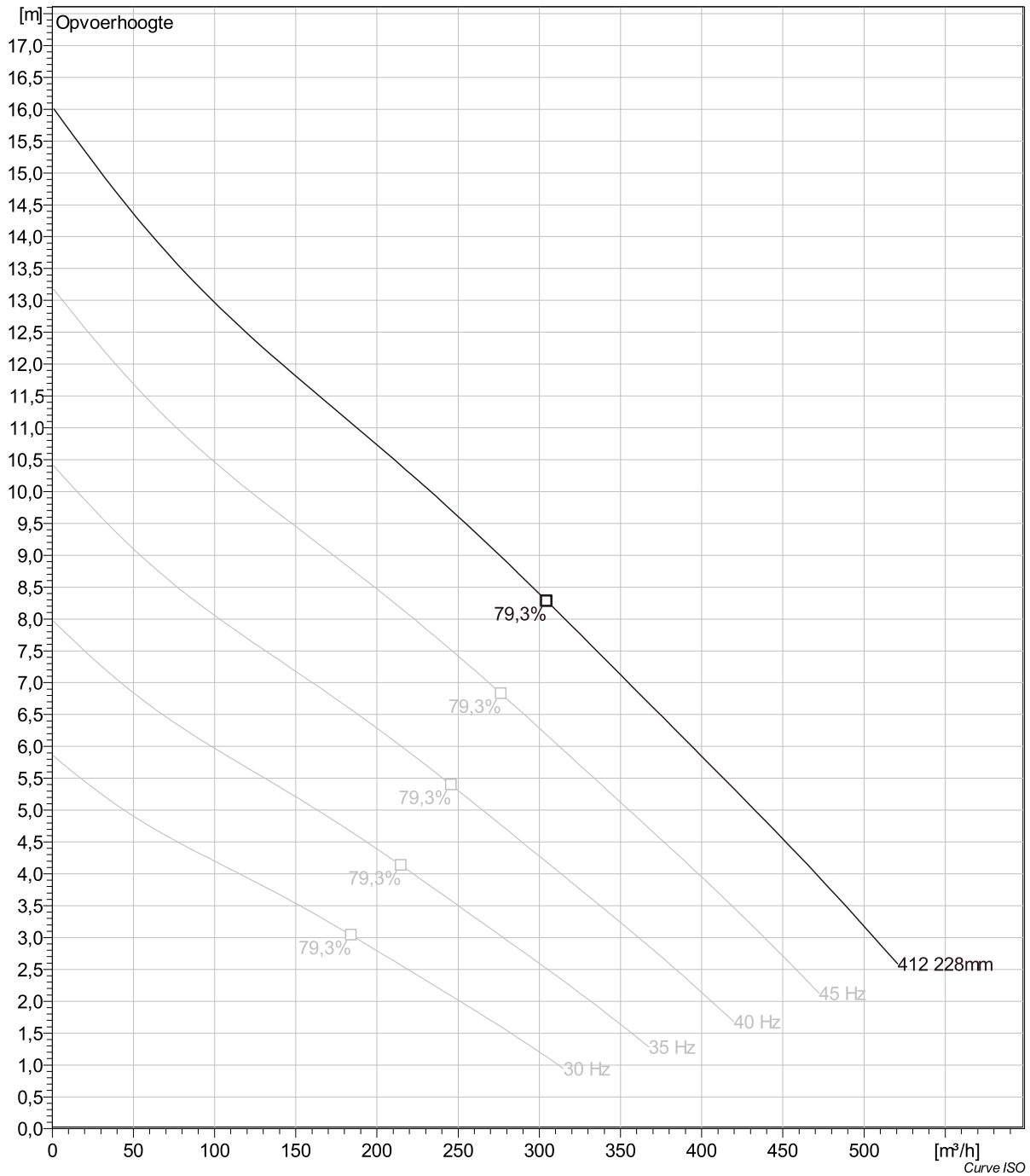

Project	Project ID	Created by	Created on	Last update
			10/5/2018	

NS 3153 LT 3~ 412
Dimensional drawing

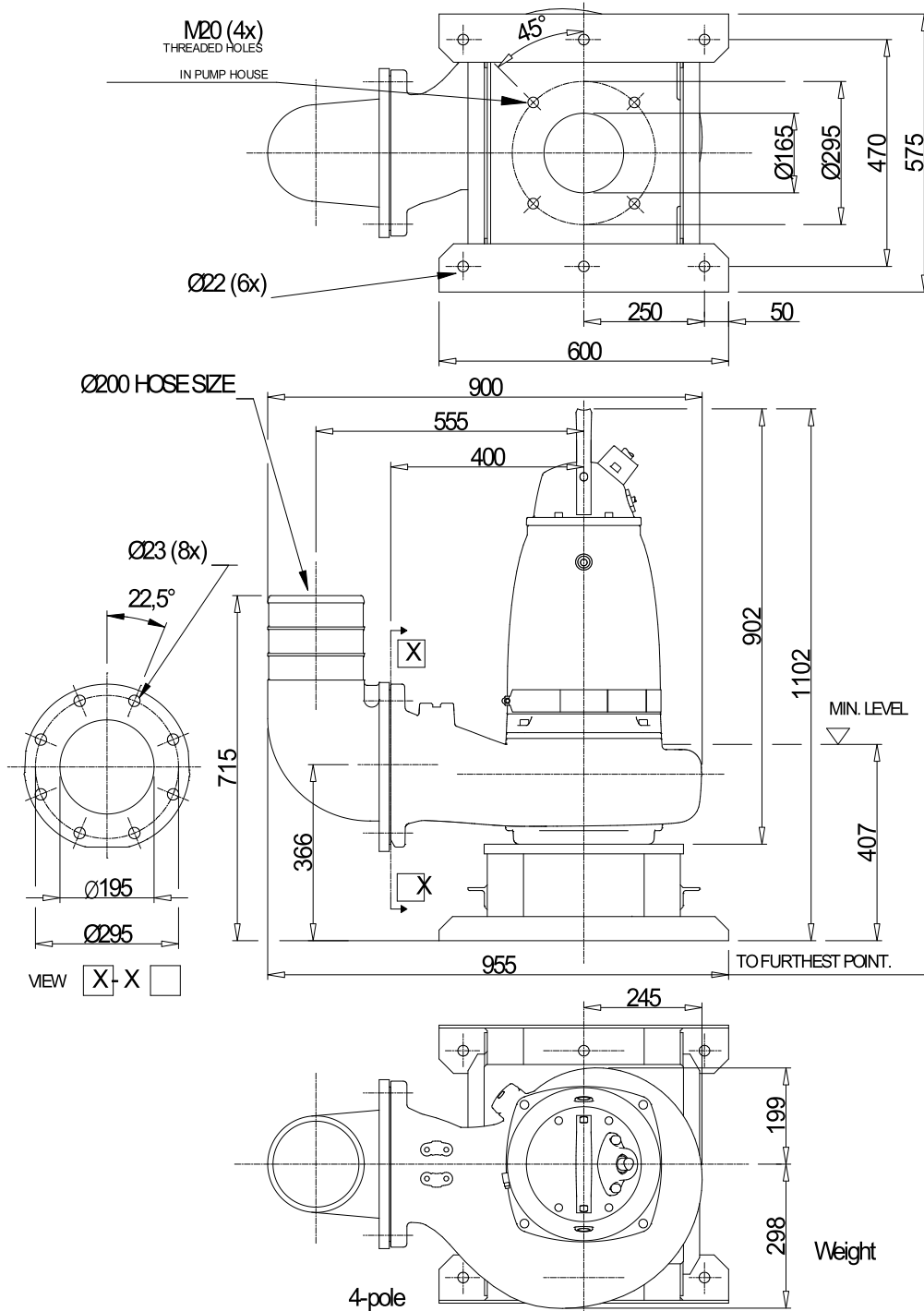

Dimensional dwg
NS 3153 LT

Project	Project ID	Created by	Created on	Last update
			10/5/2018	