

NS 3153 LT 3~ 620 Technische specificaties

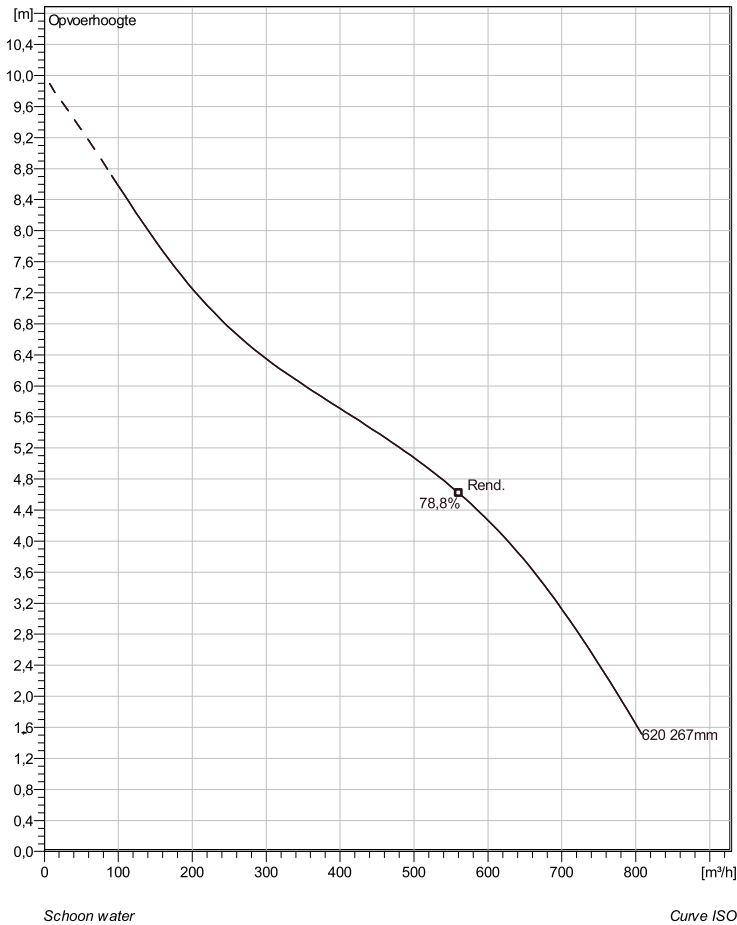

Note: Picture might not correspond to the current configuration.

General

Dompelbare pompen voorzien van een verstopingsgevoelige N-waaiër. Geschikt voor afvalwater met grotere delen zoals rioolwater, regenwater en industriële afvalwater. Materiaal gietijzer.

Impeller

Impeller material	Stainless steel
Persaansluiting	250 mm
Diameter aanzuigzijde	250 mm
Impeller diameter	267 mm
Aantal bladen	2

Motor

Motor #	N3153.660 21-18-6AA-W 9KW standaard
Stator variant	2
Frequentie	50 Hz
Nominale spanning	230 V
Aantal polen	6
Fasen	3~
Nominaal vermogen	9 kW
Toegekende stroom	36 A
Aanloopstroom	151 A
Nominaal toerental	955 rpm
Vermogensfactor	
1/1 Load	0,73
3/4 Load	0,67
1/2 Load	0,55
Motor efficiency	
1/1 Load	85,8 %
3/4 Load	87,2 %
1/2 Load	87,0 %

Soort installatie: Semi permanent, Nat

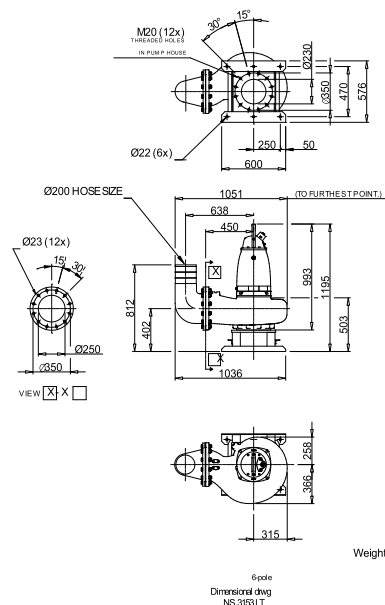

Project	Project ID	Created by	Created on 10/5/2018	Last update
---------	------------	------------	-------------------------	-------------

NS 3153 LT 3~ 620

Karakteristiek

Pomp

Persaansluiting	250 mm
Diameter aanzuigzijde	250 mm
Impeller diameter	267 mm
Aantal bladen	2

Motor

Motor #	N3153.660 21-18-6AA-W 9KW
Stator variant	2
Frequentie	50 Hz
Nominale spanning	230 V
Aantal polen	6
Fasen	3~
Nominaal vermogen	9 kW
Toegekende stroom	36 A
Aanloopstroom	151 A
Nominaal toerental	955 rpm

Vermogensfactor	
1/1 Load	0,73
3/4 Load	0,67
1/2 Load	0,55
Motor efficiency	
1/1 Load	85,8 %
3/4 Load	87,2 %
1/2 Load	87,0 %

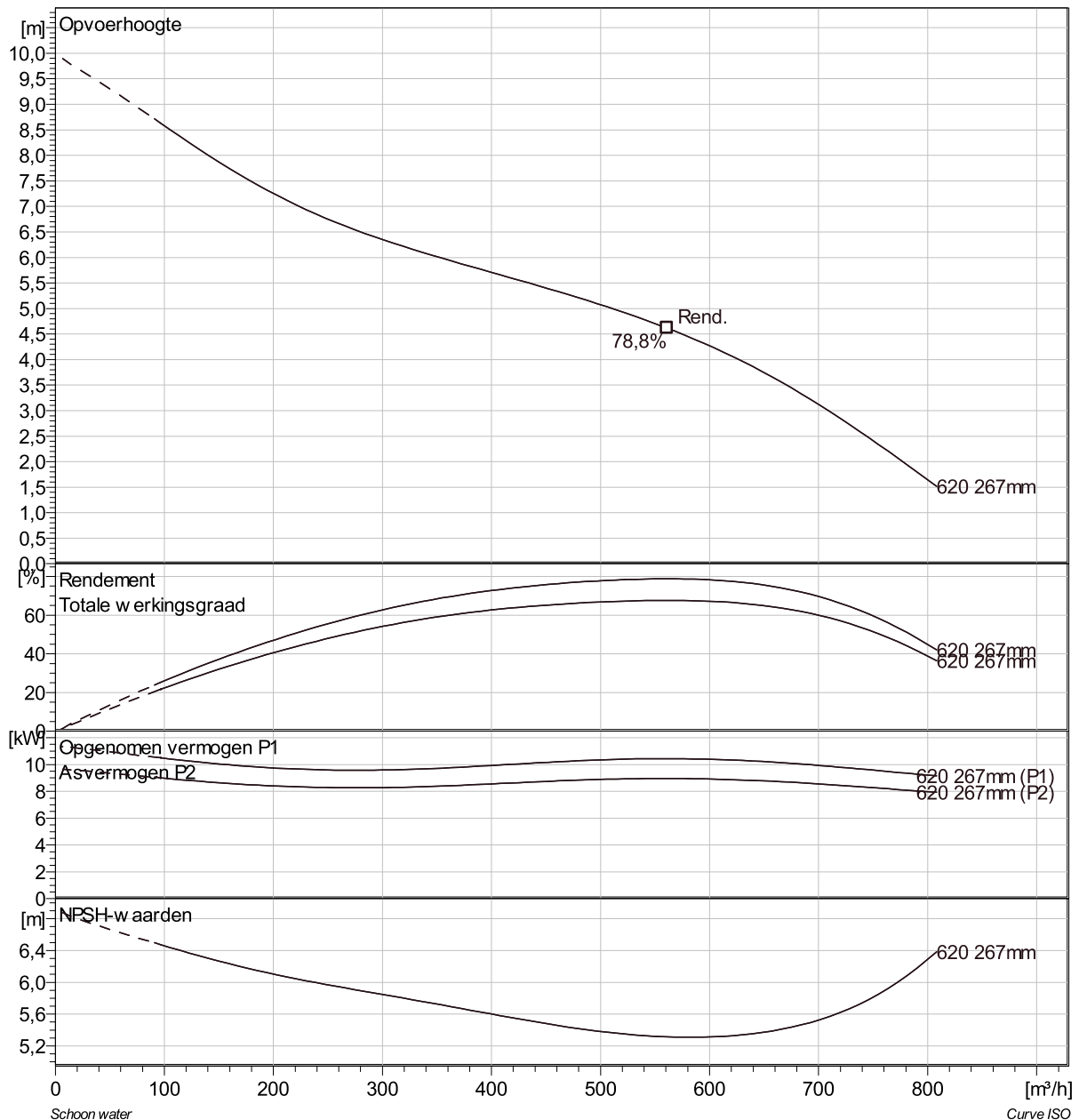

Project	Project ID	Created by	Created on 10/5/2018	Last update
---------	------------	------------	-------------------------	-------------

NS 3153 LT 3~ 620 VFD Analysis

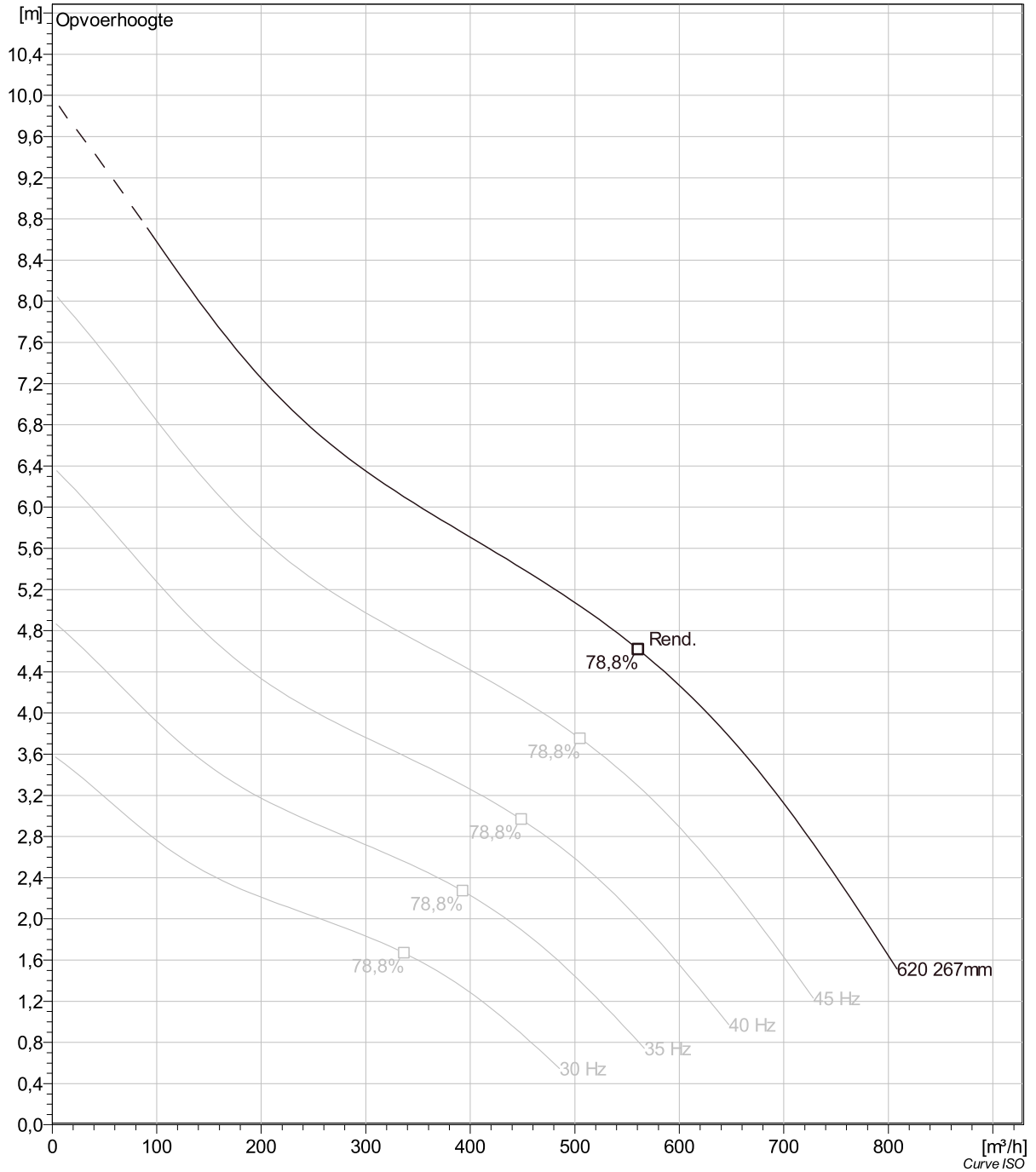

Project	Project ID	Created by	Created on	Last update
			10/5/2018	

NS 3153 LT 3~ 620 Dimensional drawing

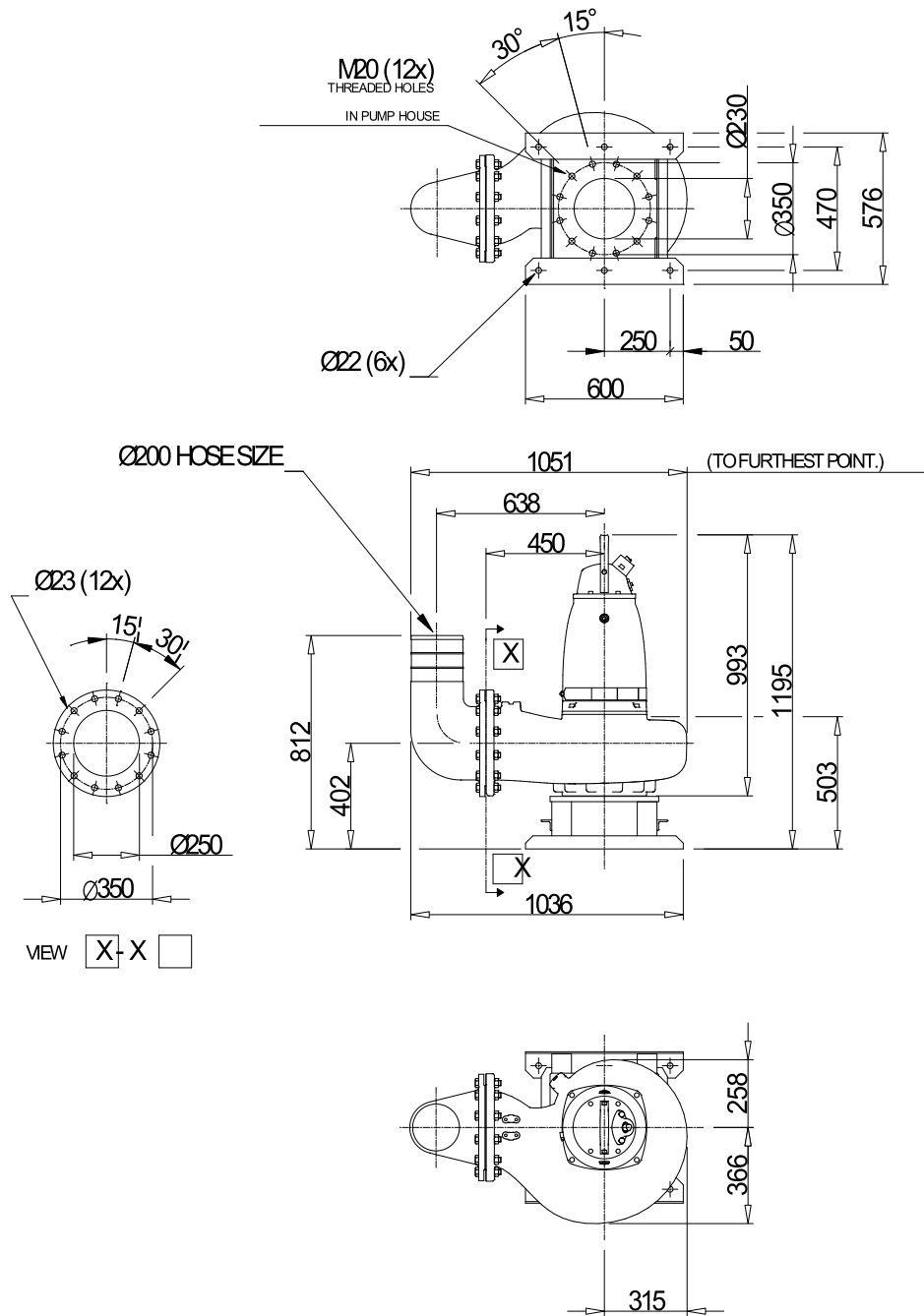

VIEW X X

Weight

6-pde
Dimensional dwg
NS3153LT

Project	Project ID	Created by	Created on	Last update
			10/5/2018	