

## NS 3153 LT 3~ 623 Technische specificaties

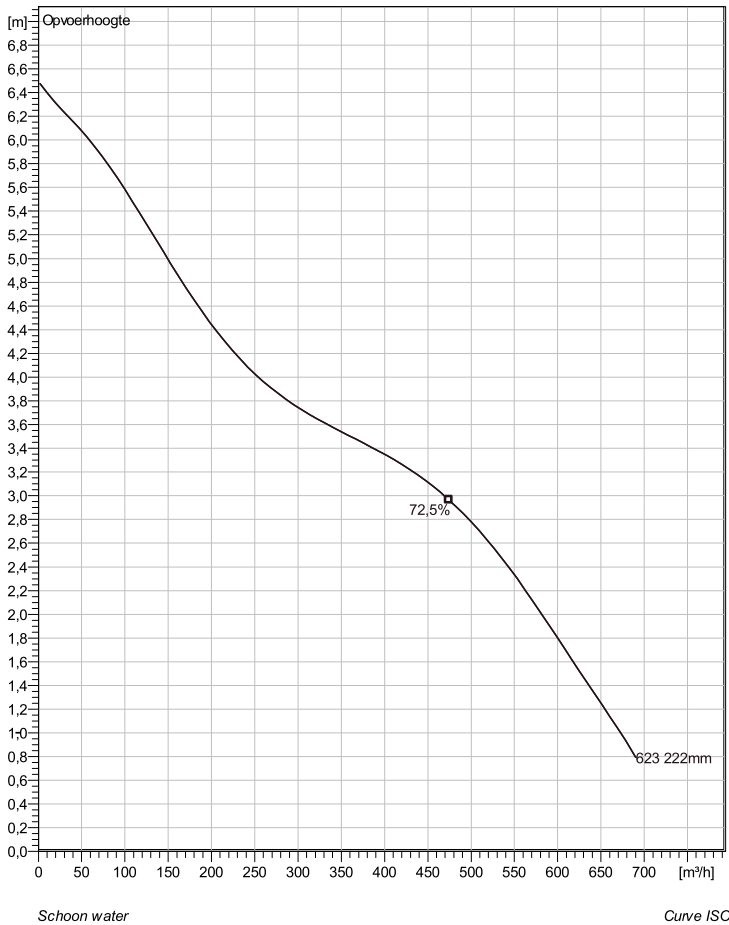

Note: Picture might not correspond to the current configuration.

### General

Dompelbare pompen voorzien van een verstopingsgevoelige N-waaiër. Geschikt voor afvalwater met grotere delen zoals rioolwater, regenwater en industriële afvalwater. Materiaal gietijzer.

### Impeller

Impeller material	Stainless steel
Persaansluiting	250 mm
Diameter aanzuigzijde	250 mm
Impeller diameter	222 mm
Aantal bladen	2

### Motor

Motor #	N3153.660 21-18-6AA-W 9KW standaard
Stator variant	2
Frequentie	50 Hz
Nominale spanning	230 V
Aantal polen	6
Fasen	3~
Nominaal vermogen	9 kW
Toegekende stroom	36 A
Aanloopstroom	151 A
Nominaal toerental	955 rpm
Vermogensfactor	
1/1 Load	0,73
3/4 Load	0,67
1/2 Load	0,55
Motor efficiency	
1/1 Load	85,8 %
3/4 Load	87,2 %
1/2 Load	87,0 %

### Soort installatie: Semi permanent, Nat

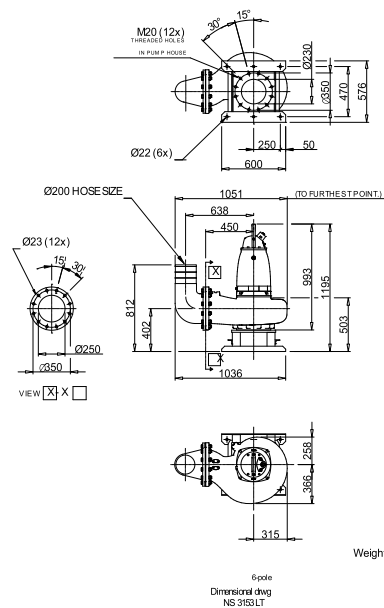

Project	Project ID	Created by	Created on 10/5/2018	Last update
---------	------------	------------	-------------------------	-------------

## NS 3153 LT 3~ 623

### Karakteristiek

#### Pomp

Persaansluiting	250 mm
Diameter aanzuigzijde	250 mm
Impeller diameter	222 mm
Aantal bladen	2

#### Motor

Motor #	N3153.660 21-18-6AA-W 9KW
Stator variant	2
Frequentie	50 Hz
Nominale spanning	230 V
Aantal polen	6
Fasen	3~
Nominaal vermogen	9 kW
Toegekende stroom	36 A
Aanloopstroom	151 A
Nominaal toerental	955 rpm

Vermogensfactor	
1/1 Load	0,73
3/4 Load	0,67
1/2 Load	0,55
Motor efficiency	
1/1 Load	85,8 %
3/4 Load	87,2 %
1/2 Load	87,0 %

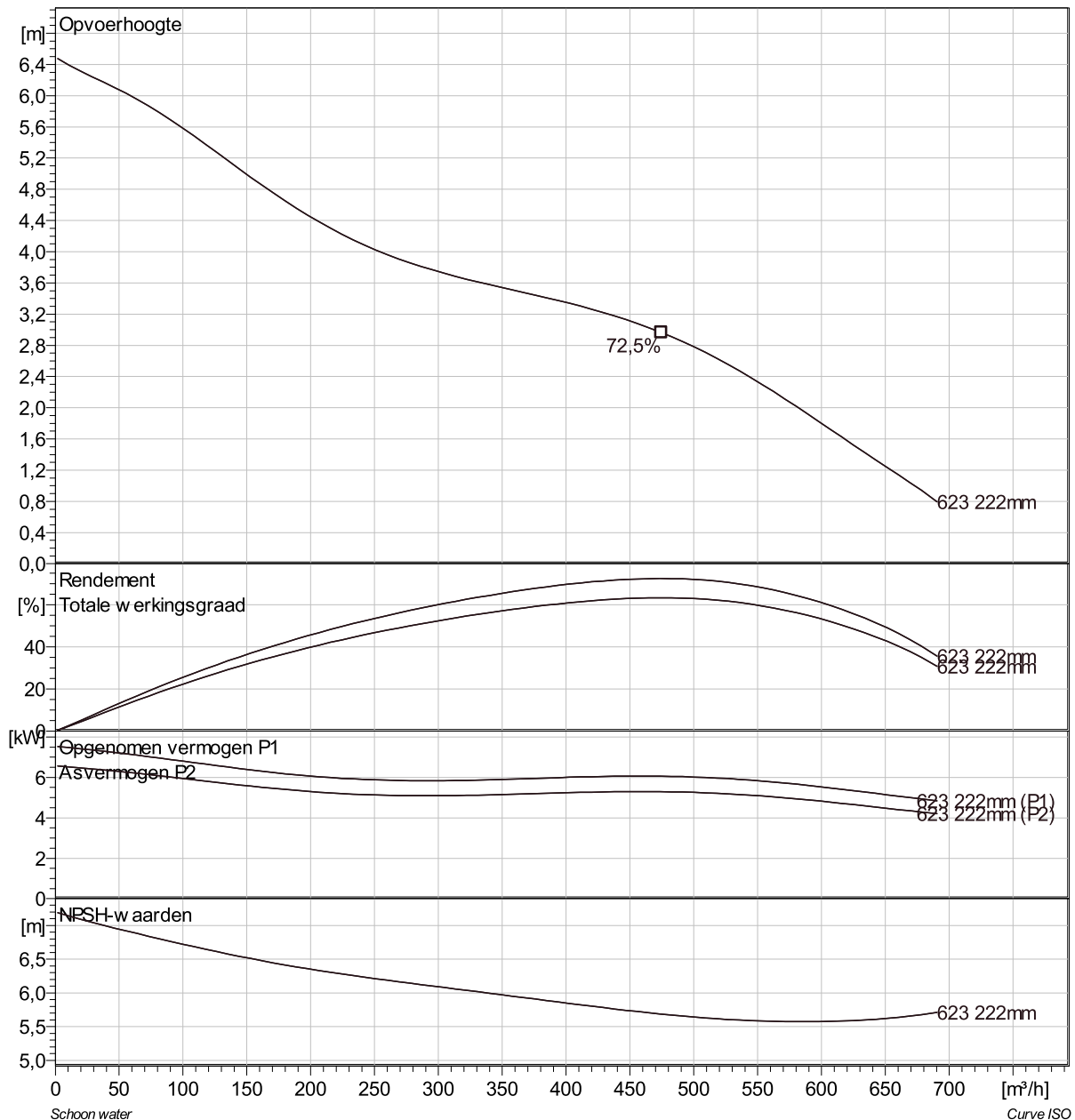

Project	Project ID	Created by	Created on 10/5/2018	Last update
---------	------------	------------	-------------------------	-------------

## NS 3153 LT 3~ 623 VFD Analysis

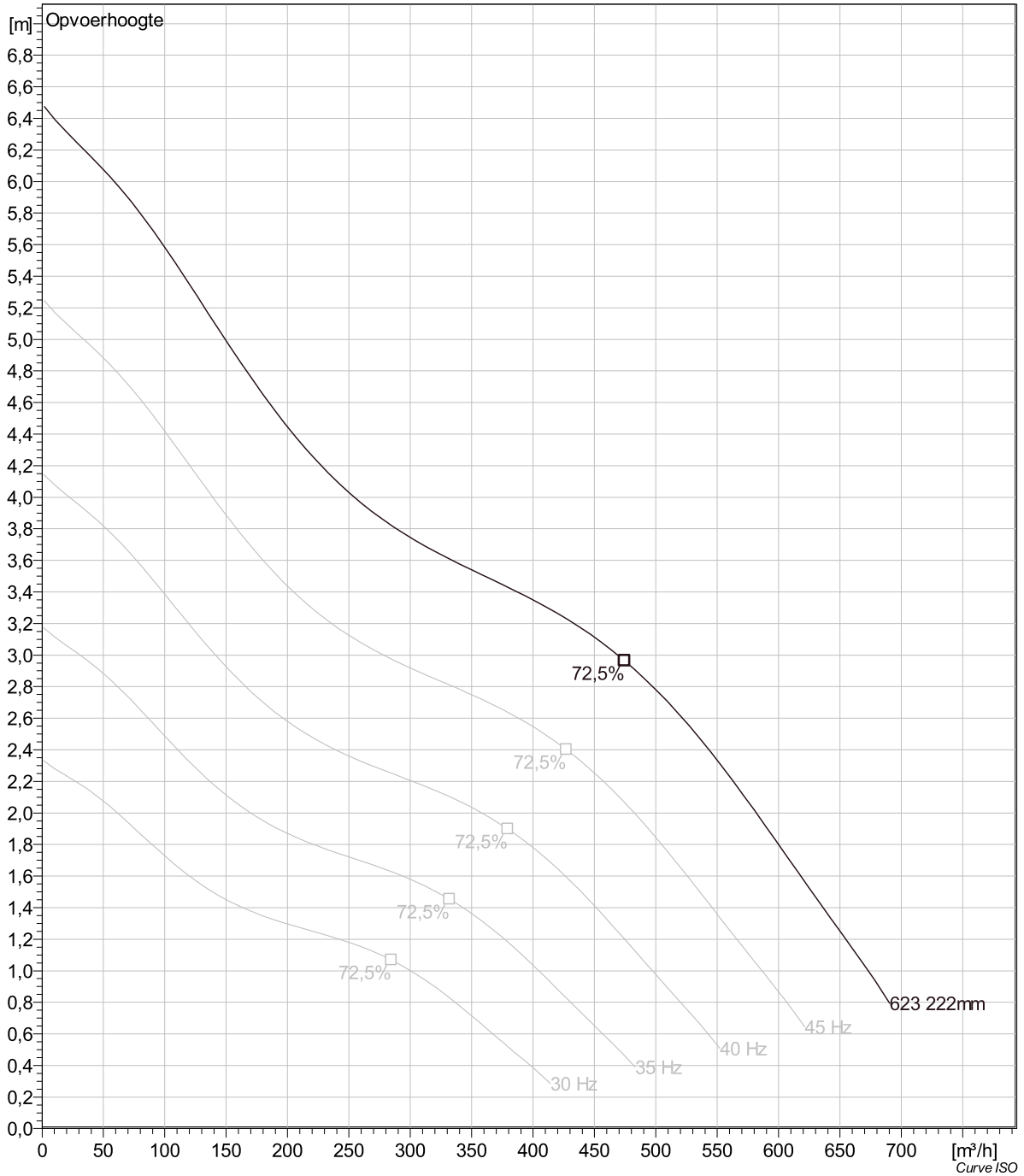

Project	Project ID	Created by	Created on	Last update
			10/5/2018	

## NS 3153 LT 3~ 623 Dimensional drawing

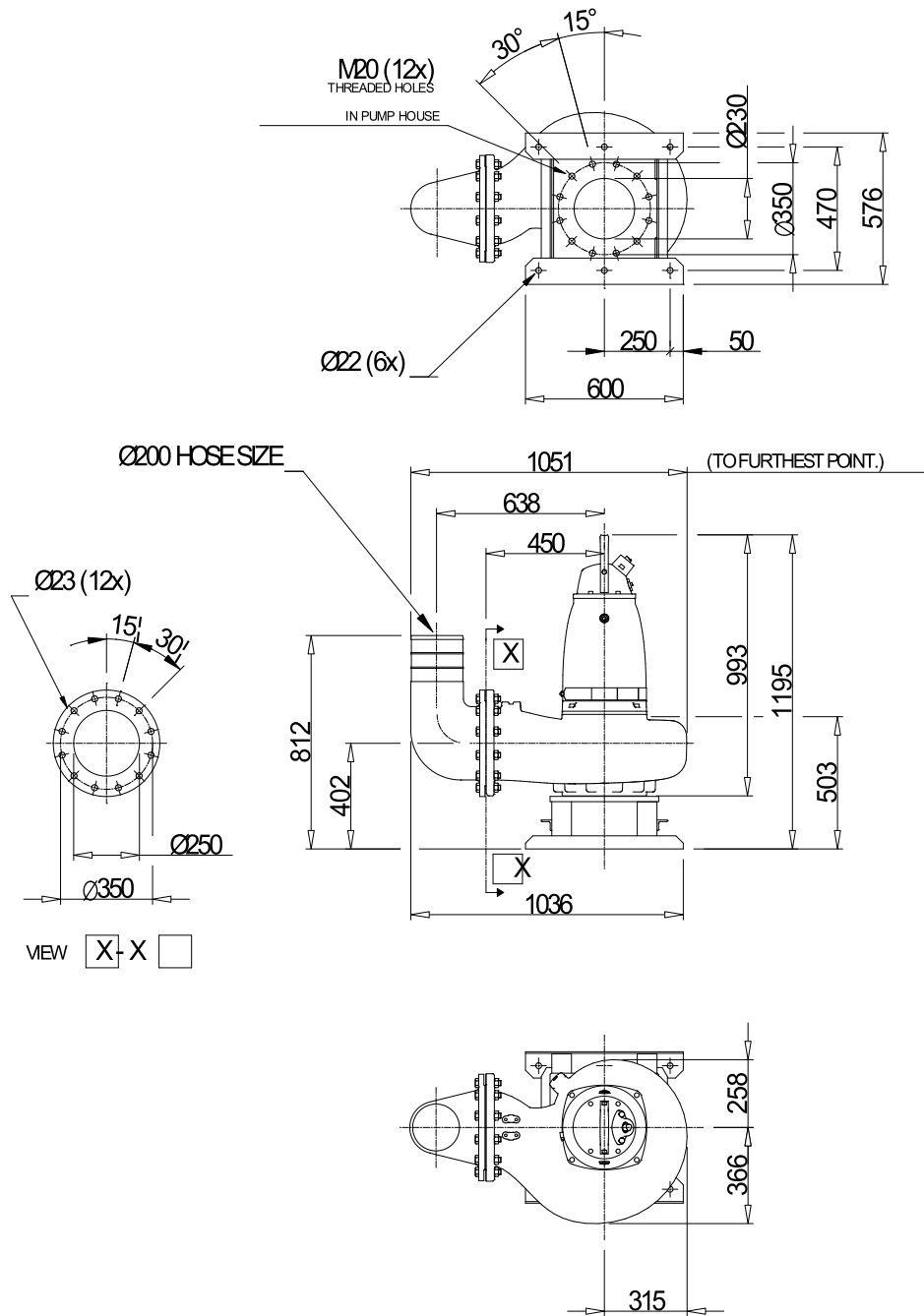

VIEW  X  X

Weight

6-pde  
Dimensional dwg  
NS3153LT

Project	Project ID	Created by	Created on	Last update
			10/5/2018	