

NS 3153 SH 3~ 270 Technische specificaties

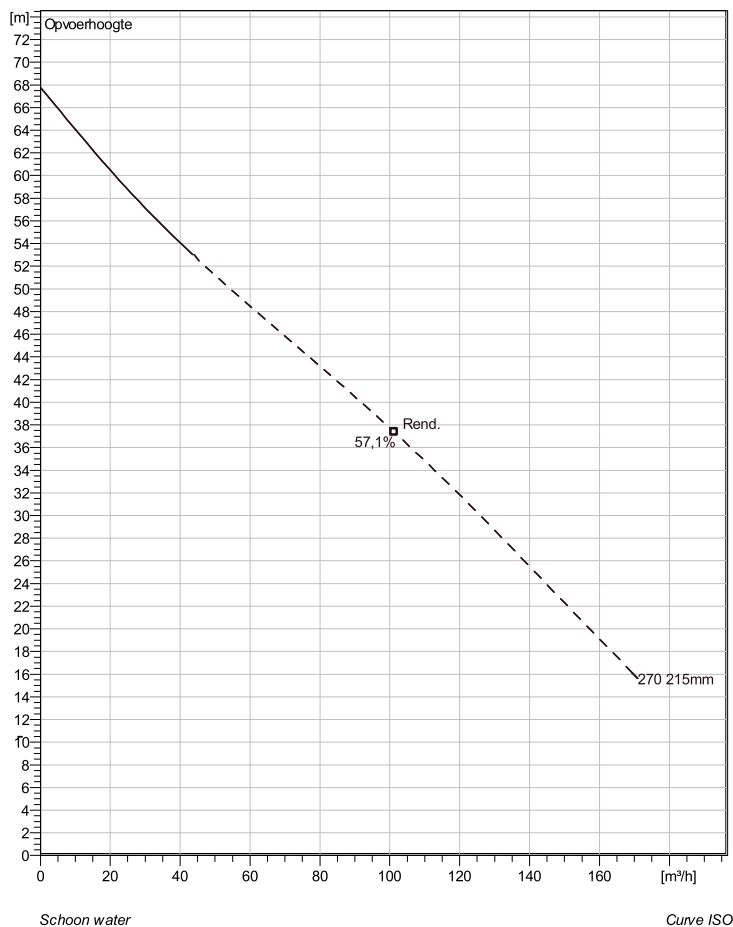

Note: Picture might not correspond to the current configuration.

General

Dompelbare pompen voorzien van een verstopingsgevoelige N-waaiër. Geschikt voor afvalwater met grotere delen zoals rioolwater, regenwater en industriële afvalwater. Materiaal gietijzer.

Impeller

Impeller materiaal	Grey cast iron
Persaansluiting	80 mm
Diameter aanzuigzijde	150 mm
Impeller diameter	215 mm
Aantal bladen	2

Motor

Motor #	N3153.181 21-18-2BB-W 15KW
Stator variant	2
Frequentie	50 Hz
Nominale spanning	230 V
Aantal polen	2
Fasen	3~
Nominaal vermogen	15 kW
Toegekende stroom	47 A
Aanloopstroom	370 A
Nominaal toerental	2915 rpm
Vermogensfactor	
1/1 Load	0,89
3/4 Load	0,84
1/2 Load	0,75
Rendement	
1/1 Load	90,0 %
3/4 Load	91,0 %
1/2 Load	91,0 %

Soort installatie: Semi permanent, Nat

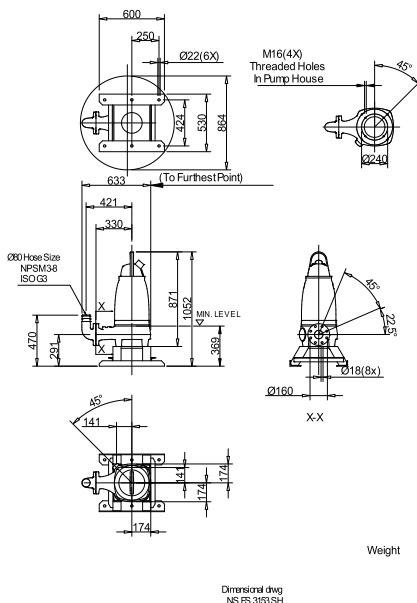

Project	Project ID	Created by	Created on 10/5/2018	Last update
---------	------------	------------	-------------------------	-------------

NS 3153 SH 3~ 270

Karakteristiek

Pomp

Persaansluiting	80 mm
Diameter aanzuigzijde	150 mm
Impeller diameter	215 mm
Aantal bladen	2

Motor

Motor #	N3153.181 21-18-2BB-W 15KW
Stator variant	2
Frequentie	50 Hz
Nominale spanning	230 V
Aantal polen	2
Fasen	3~
Nominaal vermogen	15 kW
Toegekende stroom	47 A
Aanloopstroom	370 A
Nominaal toerental	2915 rpm

Vermogensfactor	
1/1 Load	0,89
3/4 Load	0,84
1/2 Load	0,75
Rendement	
1/1 Load	90,0 %
3/4 Load	91,0 %
1/2 Load	91,0 %

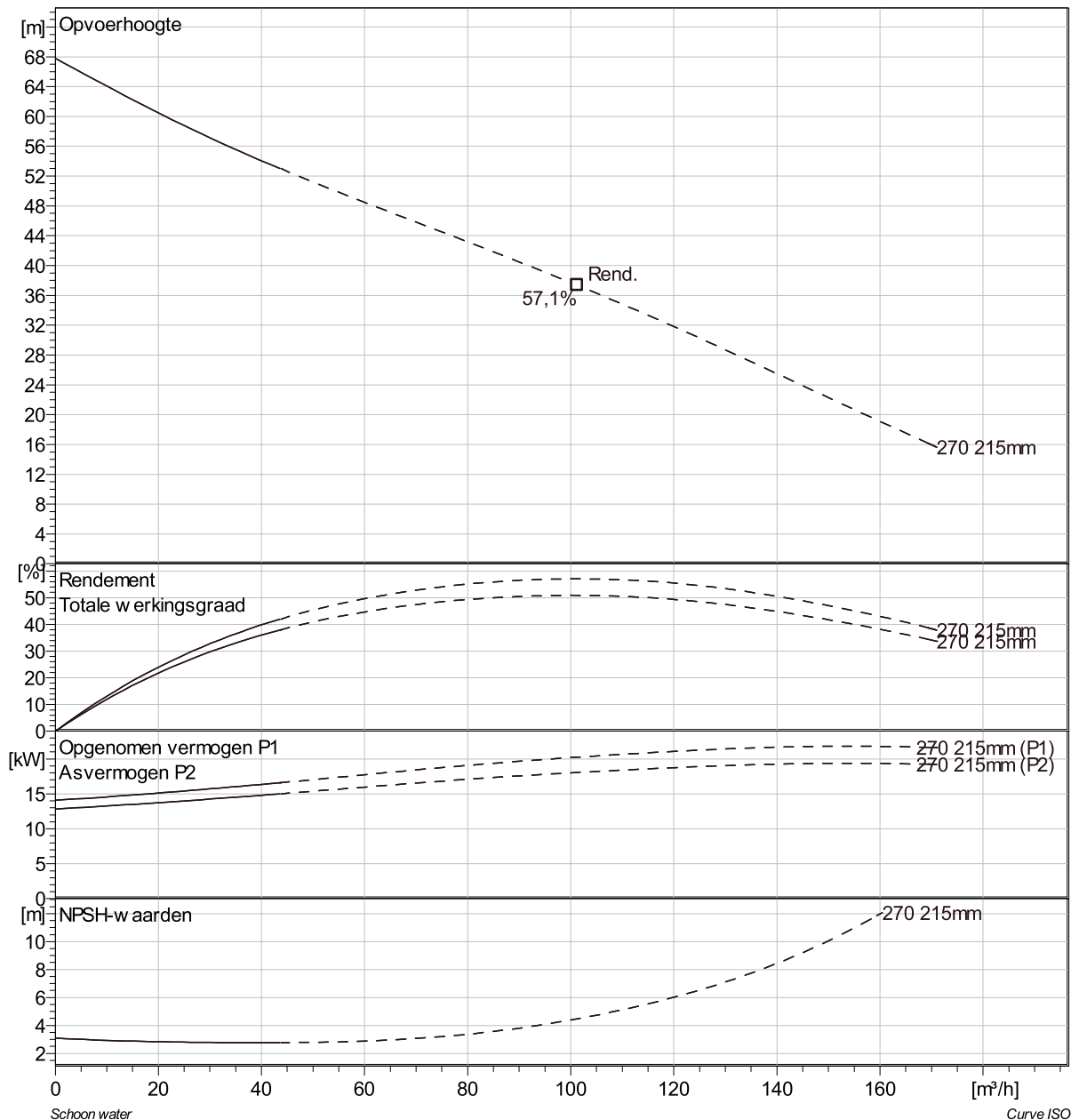

Project	Project ID	Created by	Created on 10/5/2018	Last update
---------	------------	------------	-------------------------	-------------

NS 3153 SH 3~ 270 VFD Analysis

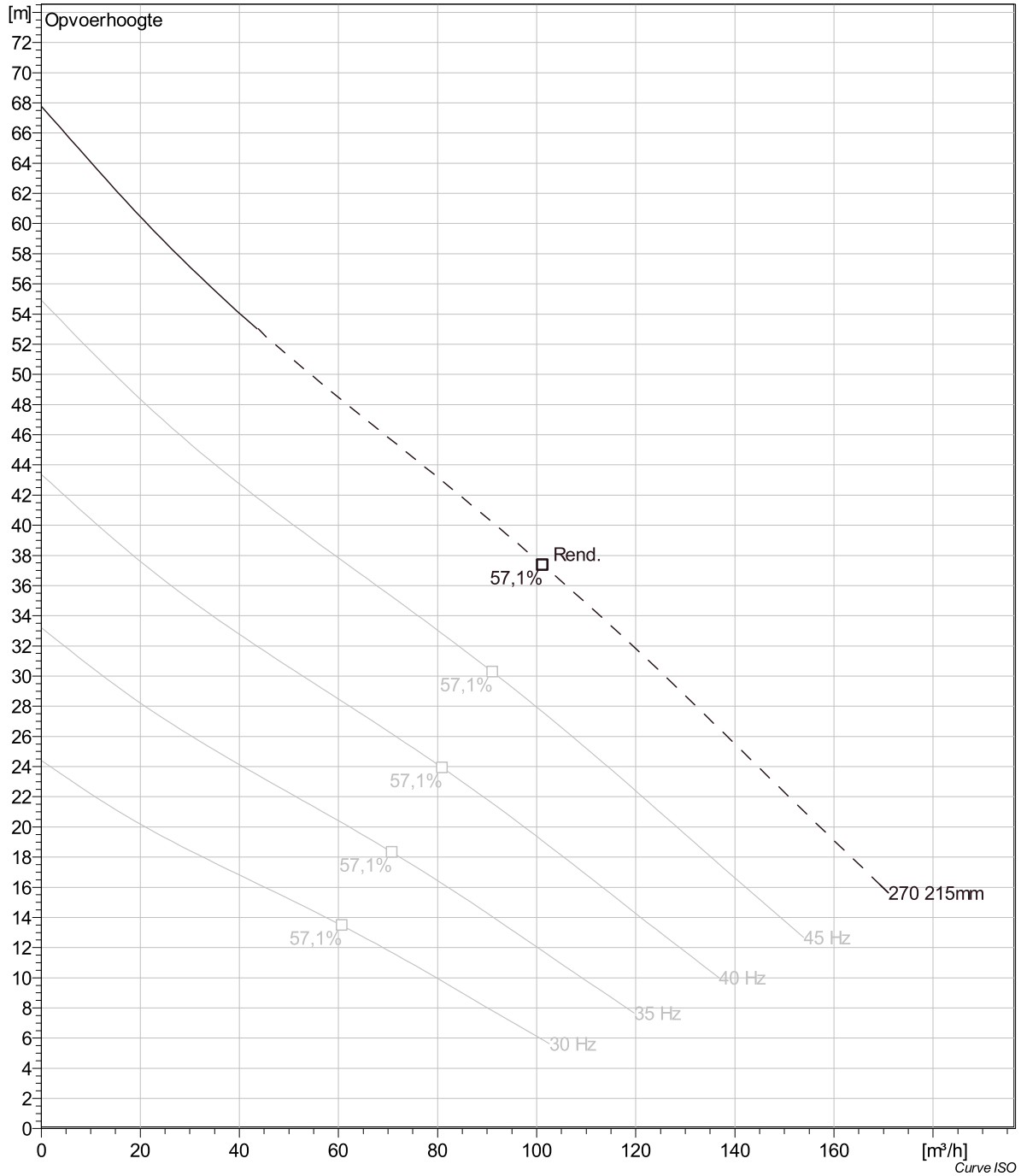

Project	Project ID	Created by	Created on	Last update
			10/5/2018	

NS 3153 SH 3~ 270 Dimensional drawing

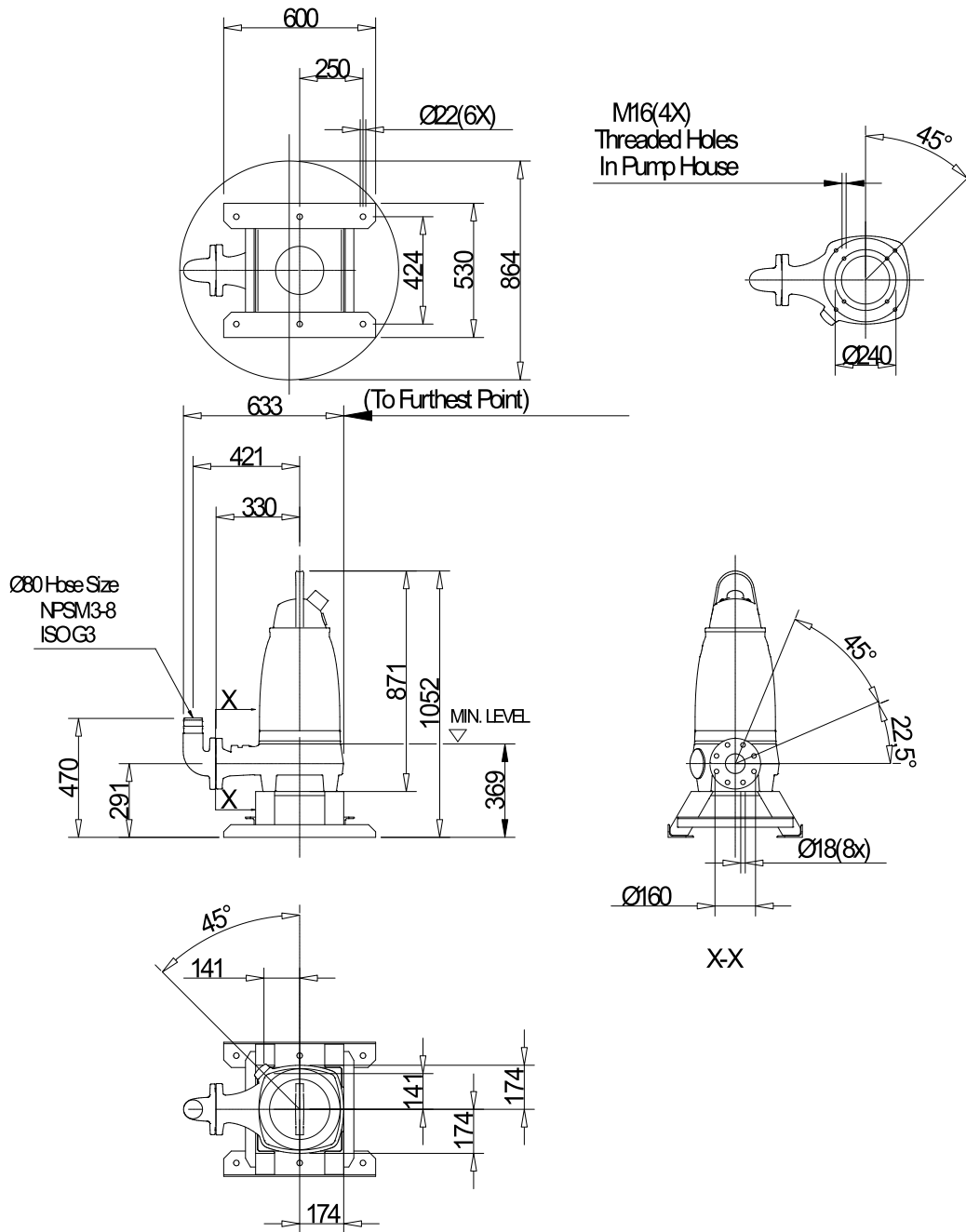

Weight

Dimensional dwg
NS,FS3153SH

Project	Project ID	Created by	Created on	Last update
			10/5/2018	