

## NP 3171 HT 3~ 451 Technische specificaties

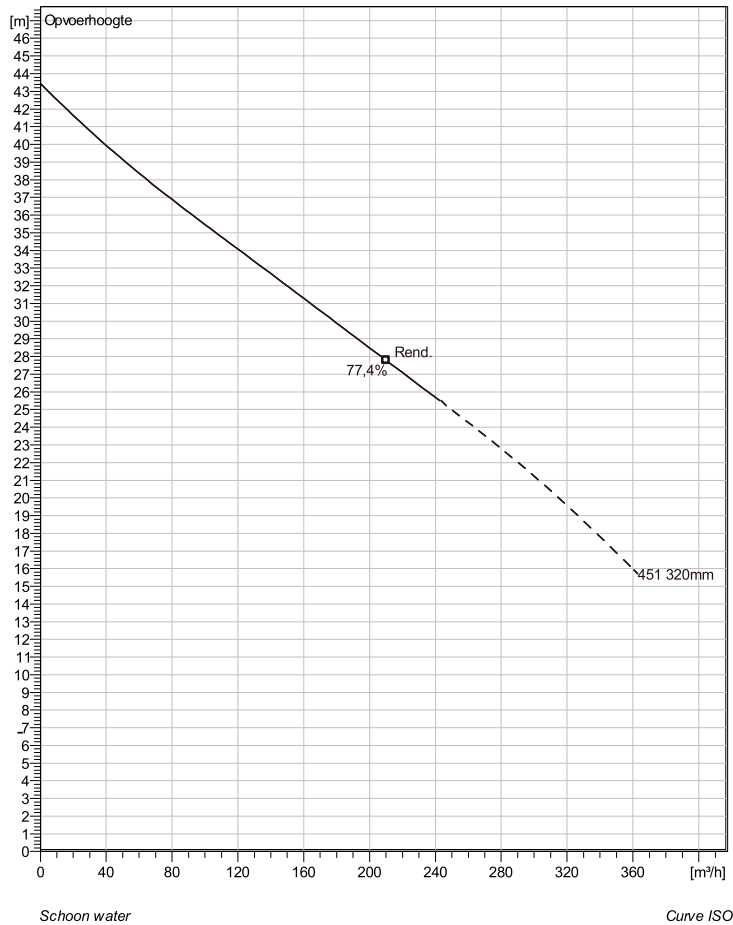

Note: Picture might not correspond to the current configuration.

### General

Dompelbare pompen voorzien van een verstoppingsgevoelige N-waaiër. Geschikt voor afvalwater met grotere delen zoals rioolwater, regenwater en industriële afvalwater. Materiaal gietijzer.

### Impeller

Impeller material	Grey cast iron
Persaansluiting	100 mm
Diameter aanzuigzijde	100 mm
Impeller diameter	320 mm
Aantal bladen	2

### Motor

Motor #	N3171.181 25-19-4AA-W 22KW standaard
Stator variant	2
Frequentie	50 Hz
Nominale spanning	230 V
Aantal polen	4
Fasen	3~
Nominaal vermogen	22 kW
Toegekende stroom	73 A
Aanloopstroom	470 A
Nominaal toerental	1460 rpm
Vermogensfactor	
1/1 Load	0,86
3/4 Load	0,80
1/2 Load	0,70
Motor efficiency	
1/1 Load	88,5 %
3/4 Load	89,5 %
1/2 Load	90,0 %

### Soort installatie: Semi Permanent, Nat

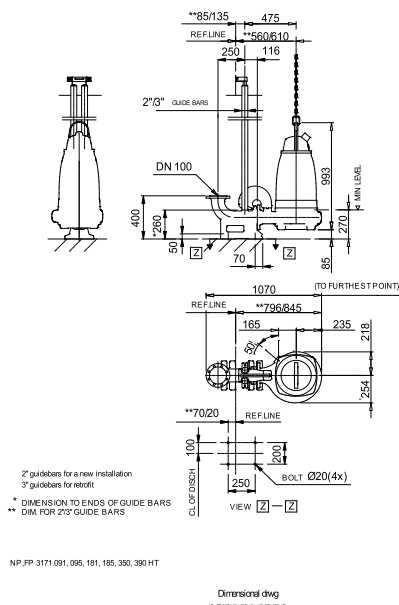

Project	Project ID	Created by	Created on 9/27/2018	Last update
---------	------------	------------	-------------------------	-------------

## NP 3171 HT 3~ 451

### Karakteristiek

#### Pomp

Persaansluiting	100 mm
Diameter aanzuigzijde	100 mm
Impeller diameter	320 mm
Aantal bladen	2

#### Motor

Motor #	N3171.181 25-19-4AA-W 22KW
Stator variant	2
Frequentie	50 Hz
Nominale spanning	230 V
Aantal polen	4
Fasen	3~
Nominaal vermogen	22 kW
Toegekende stroom	73 A
Aanloopstroom	470 A
Nominaal toerental	1460 rpm

Vermogensfactor	
1/1 Load	0,86
3/4 Load	0,80
1/2 Load	0,70
Motor efficiency	
1/1 Load	88,5 %
3/4 Load	89,5 %
1/2 Load	90,0 %

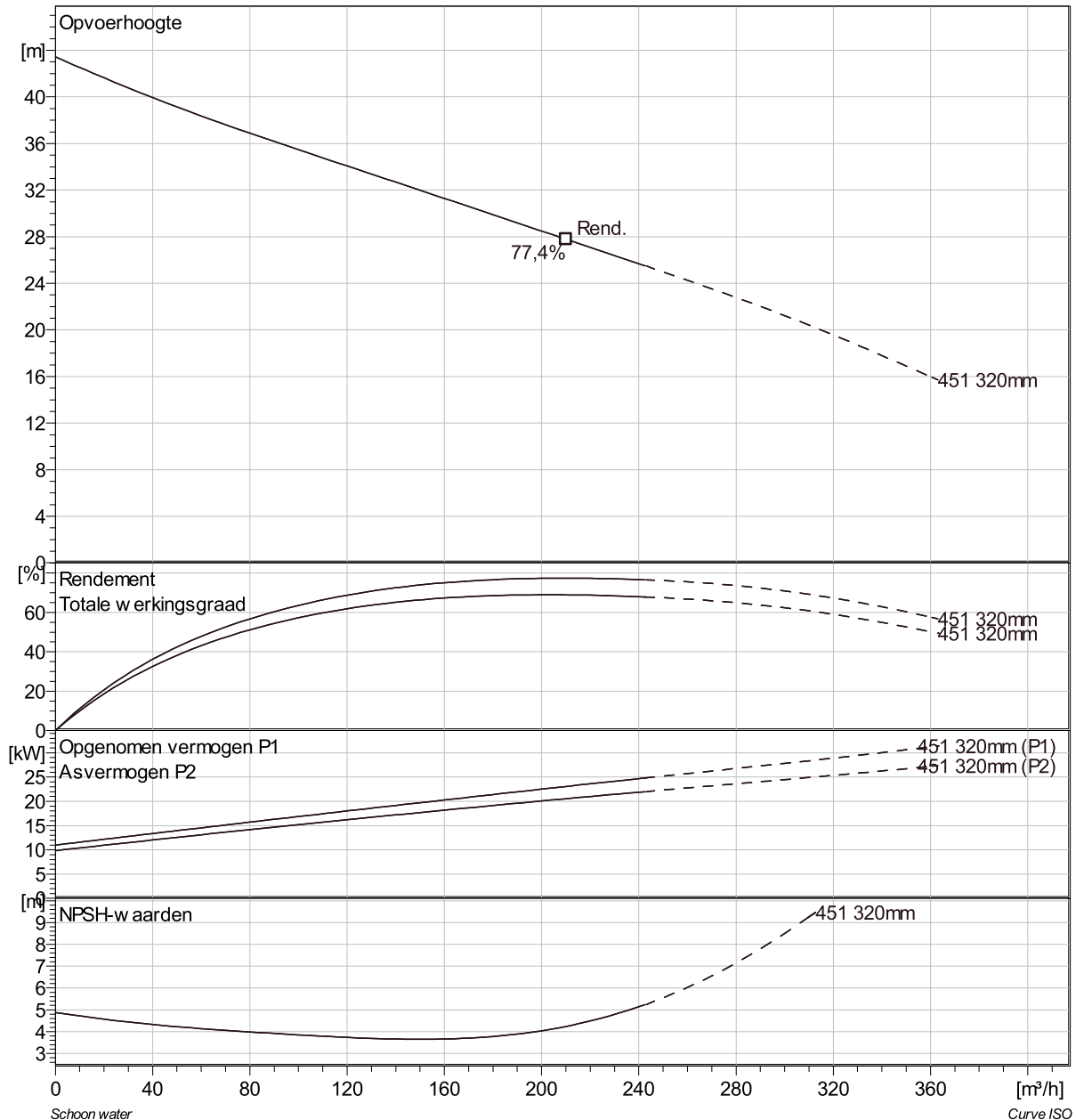

Project	Project ID	Created by	Created on 9/27/2018	Last update
---------	------------	------------	-------------------------	-------------

## NP 3171 HT 3~ 451 VFD Analysis

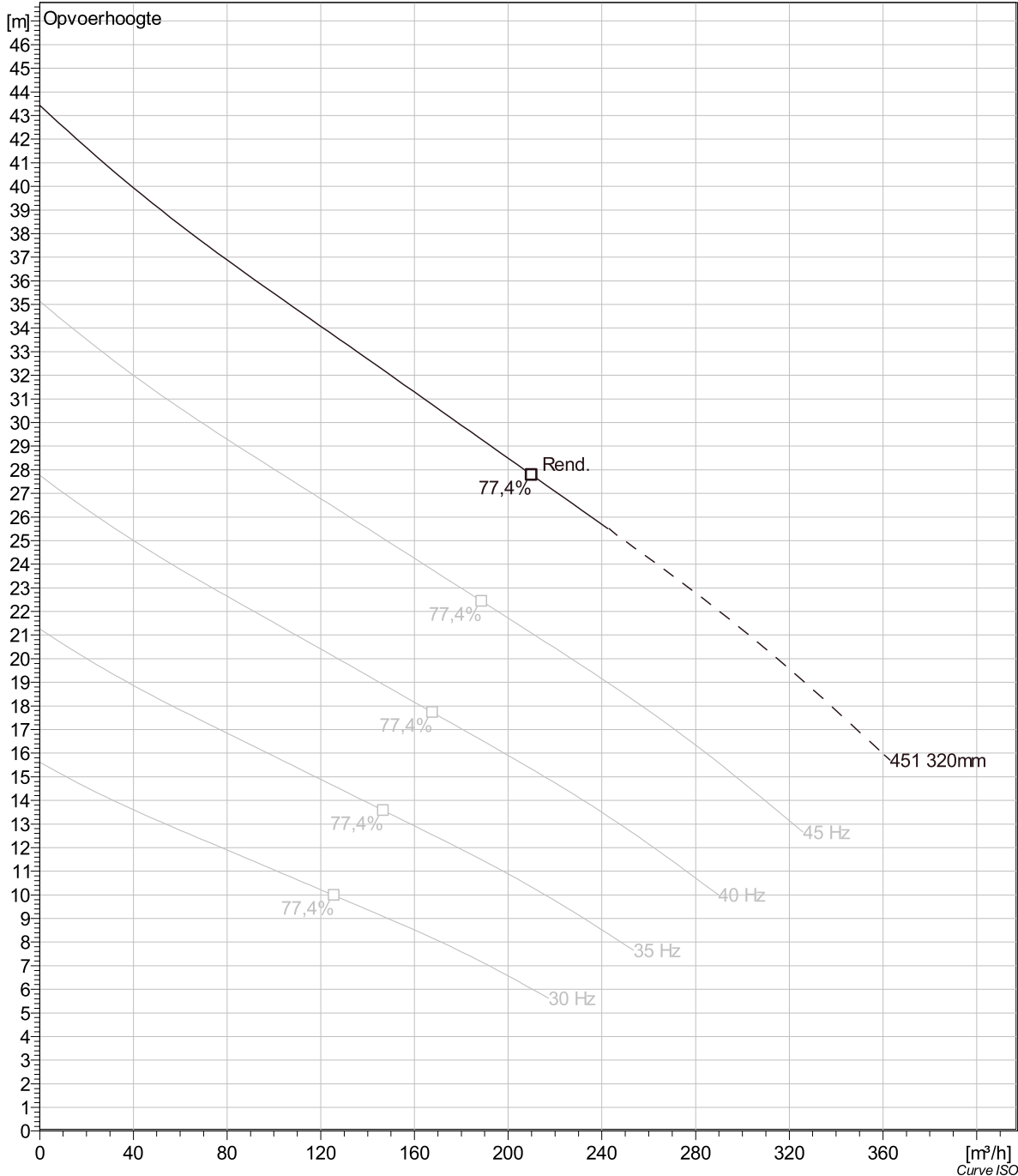

Project	Project ID	Created by	Created on	Last update
			9/27/2018	

## NP 3171 HT 3~ 451 Dimensional drawing

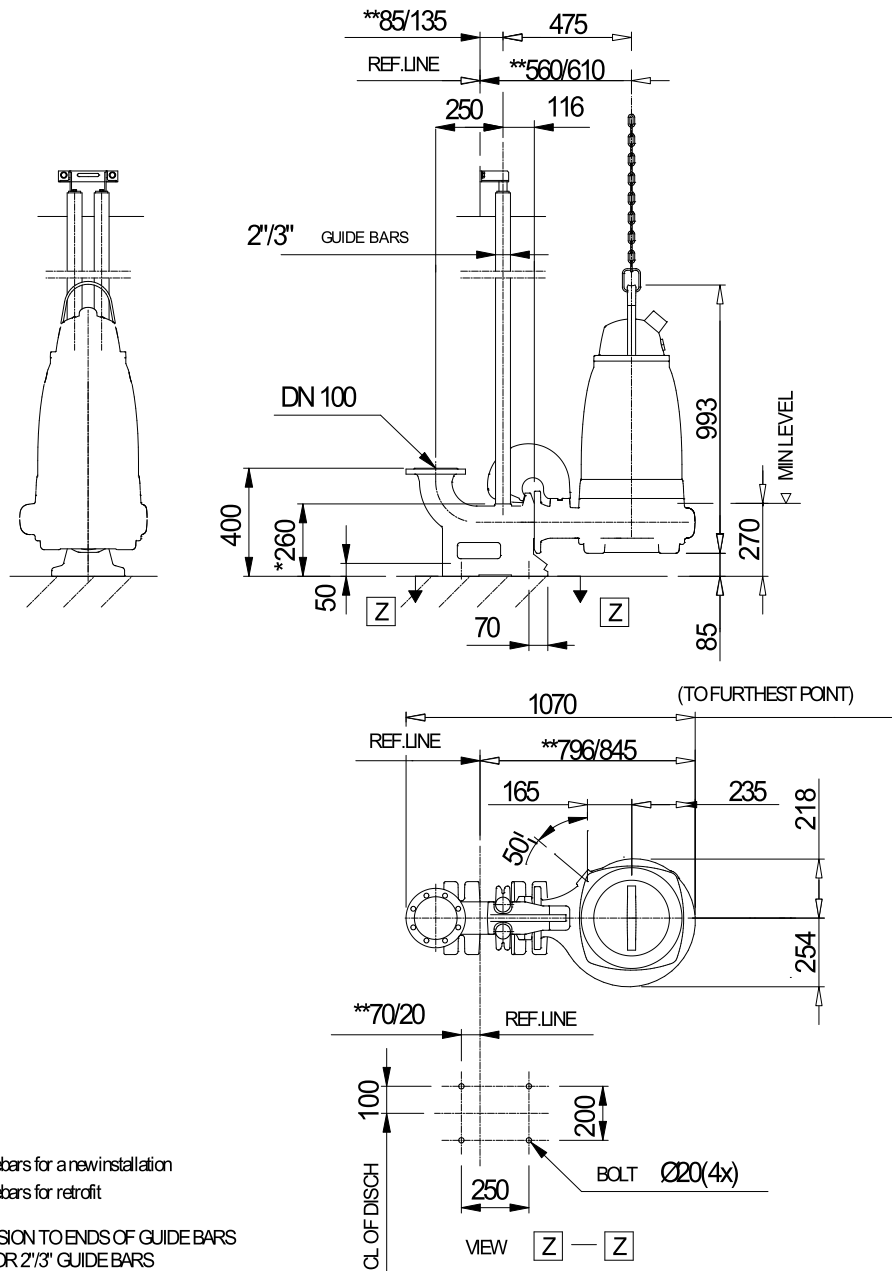

2' guidebars for a new installation  
3' guidebars for retrofit

\* DIMENSION TO ENDS OF GUIDE BARS  
\*\* DIM. FOR 2' 3/4" GUIDE BARS

NP,FP 3171.091, 095, 181, 185, 350, 390 HT

Dimensional dwg

NP,FP 3171.091,095,181,185,350,390 HT

Project	Project ID	Created by	Created on	Last update
			9/27/2018	