

NP 3171 LT 3~ 615

Technische specificaties

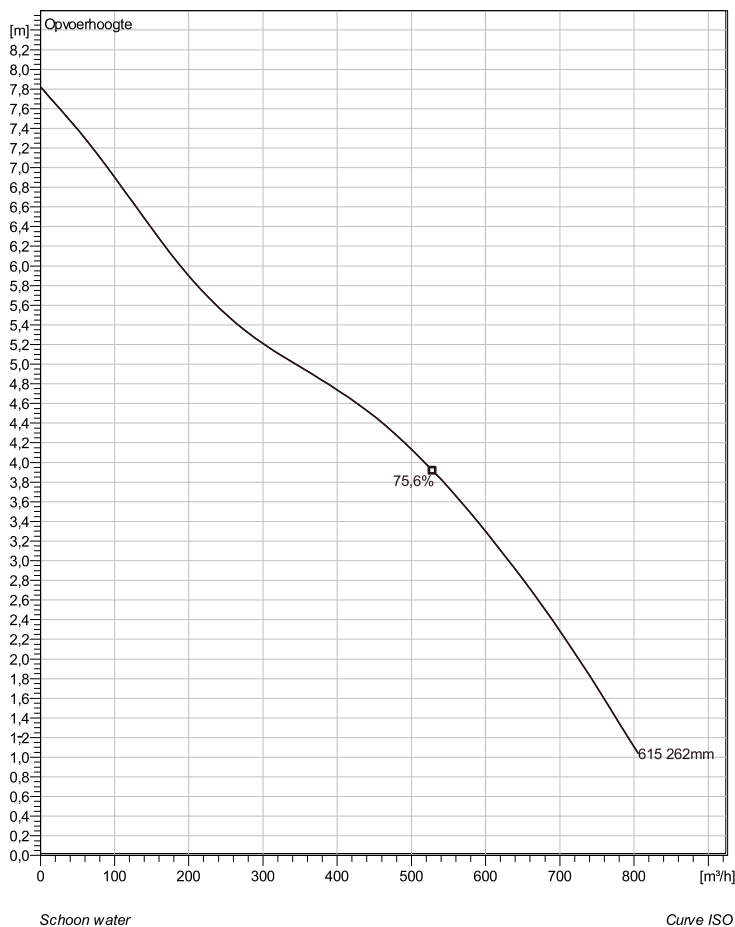

Note: Picture might not correspond to the current configuration.

General

Dompelpompen voorzien van een verstopingsongevoeilige N-waaijer. Geschikt voor afvalwater met grotere delen zoals rioolwater, regenwater en industriële afvalwater. Materiaal gietijzer.

Impeller

Impeller material	Grey cast iron
Persaansluiting	250 mm
Diameter aanzuigzijde	250 mm
Impeller diameter	262 mm
Aantal bladen	2

Motor

Motor #	N3171.800 25-32-6KE-W IE3 10KW standaard
Stator variant	2
Frequentie	50 Hz
Nominale spanning	230 V
Aantal polen	6
Fasen	3~
Nominaal vermogen	10 kW
Toegekende stroom	32 A
Aanloopstroom	251 A
Nominaal toerental	980 rpm
Vermogensfactor	
1/1 Load	0,84
3/4 Load	0,79
1/2 Load	0,67
Motor efficiency	
1/1 Load	92,1 %
3/4 Load	92,3 %
1/2 Load	91,5 %

Soort installatie: Semi Permanent, Nat

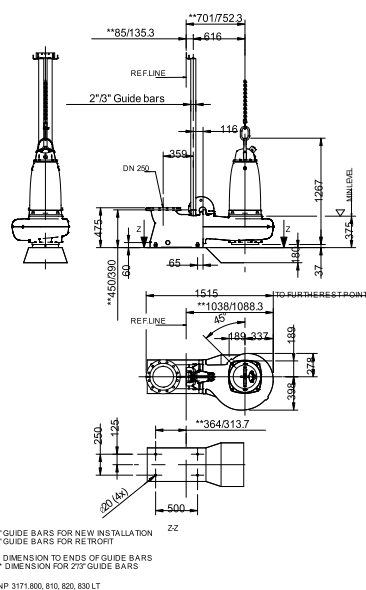

Project	Project ID	Created by	Created on	Last update
			9/27/2018	

NP 3171 LT 3~ 615

Karakteristiek

Pomp

Persaansluiting	250 mm
Diameter aanzuigzijde	250 mm
Impeller diameter	262 mm
Aantal bladen	2

Motor

Motor #	N3171.800 25-32-6KE-W IE3 10KW
Stator variant	2
Frequentie	50 Hz
Nominale spanning	230 V
Aantal polen	6
Fasen	3~
Nominaal vermogen	10 kW
Toegekende stroom	32 A
Aanloopstroom	251 A
Nominaal toerental	980 rpm

Vermogensfactor	
1/1 Load	0,84
3/4 Load	0,79
1/2 Load	0,67
Motor efficiency	
1/1 Load	92,1 %
3/4 Load	92,3 %
1/2 Load	91,5 %

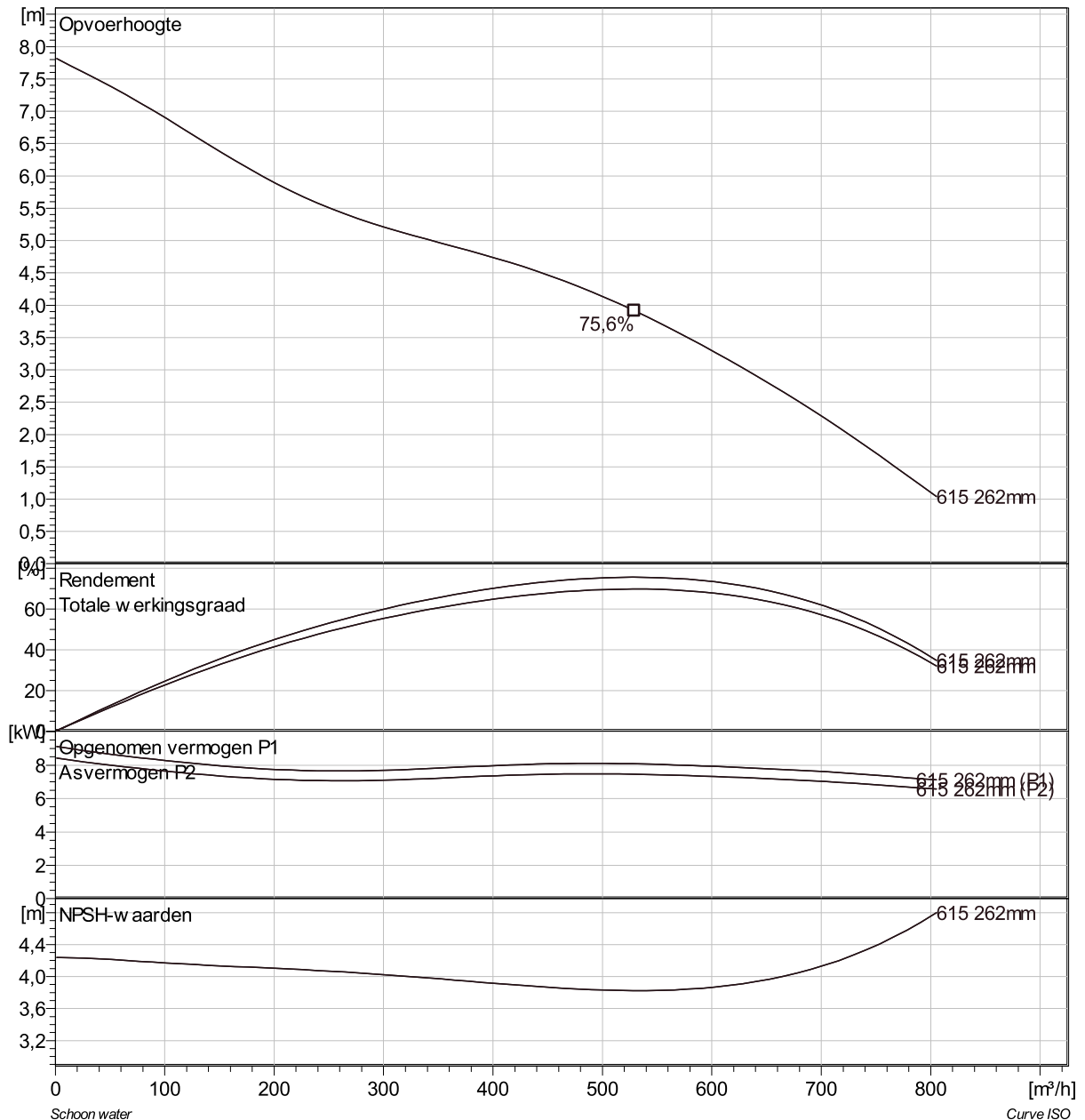

Project	Project ID	Created by	Created on 9/27/2018	Last update
---------	------------	------------	-------------------------	-------------

NP 3171 LT 3~ 615 VFD Analysis

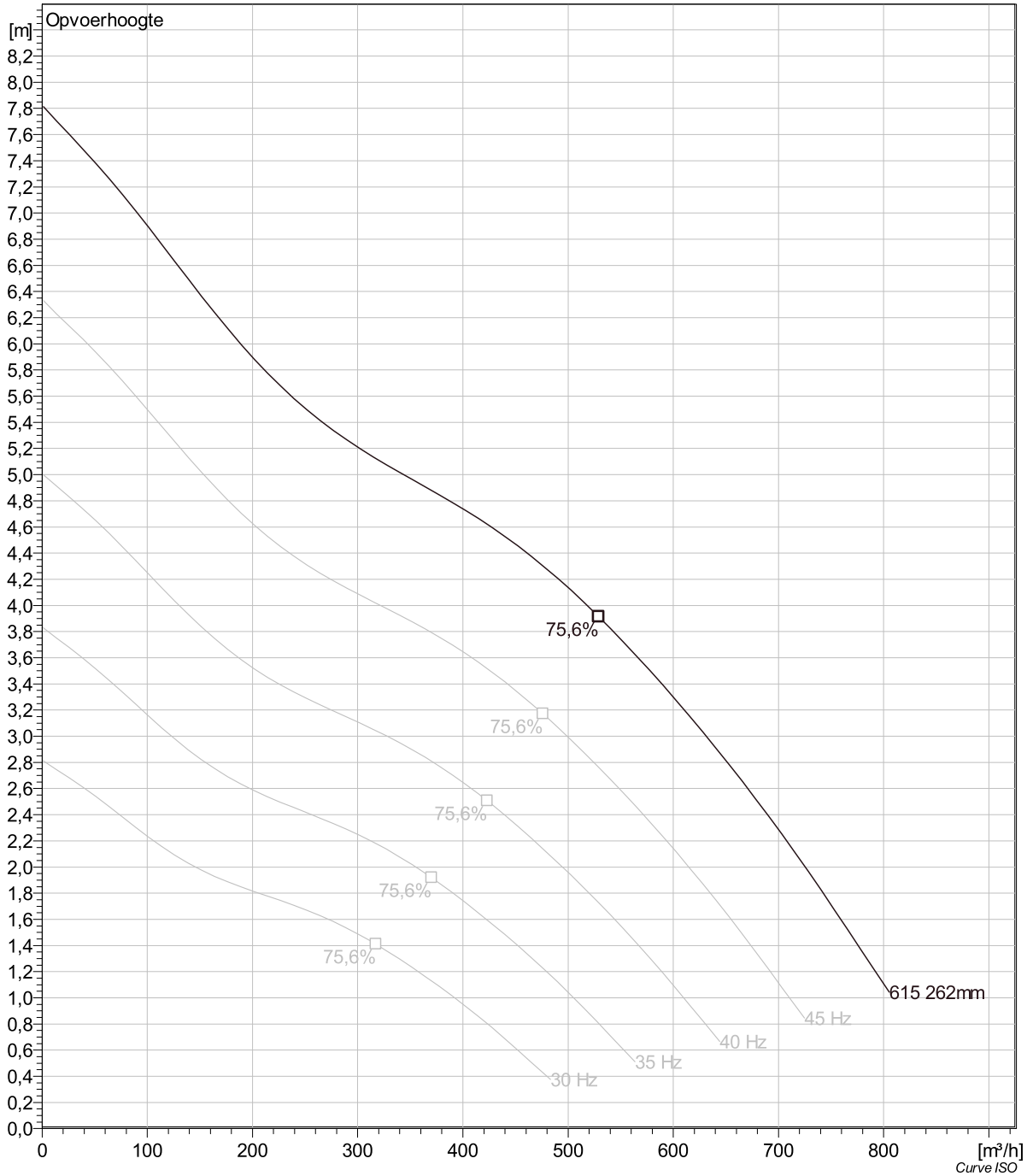

Project	Project ID	Created by	Created on	Last update
			9/27/2018	

NP 3171 LT 3~ 615 Dimensional drawing

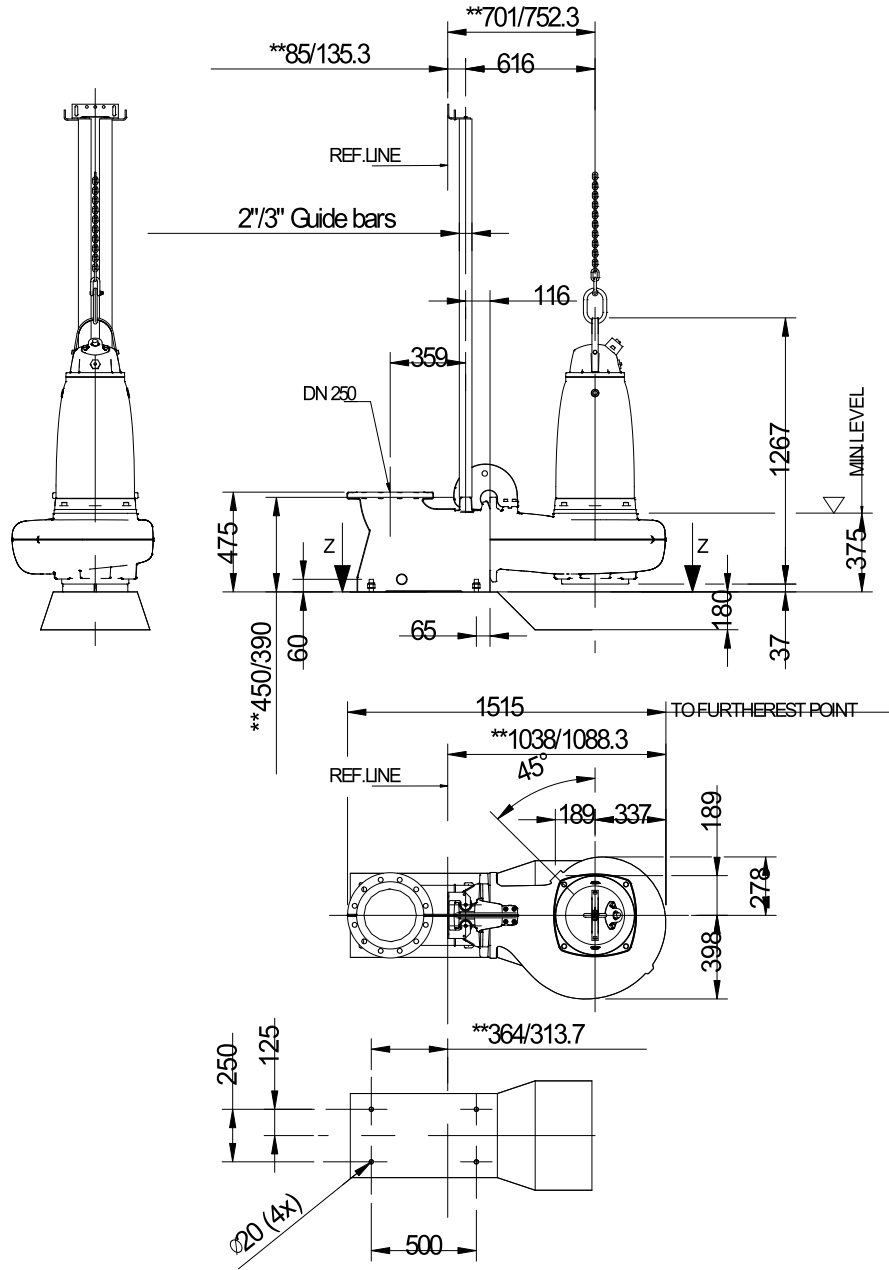

2" GUIDE BARS FOR NEW INSTALLATION
3" GUIDE BARS FOR RETROFIT

* DIMENSION TO ENDS OF GUIDE BARS
** DIMENSION FOR 2"/3" GUIDE BARS

NP 3171.800, 810, 820, 830 LT

NP3171.800,810,820,830 LT

Project	Project ID	Created by	Created on	Last update
			9/27/2018	