



## NP 3171 MT 3~ 430

### Karakteristiek

#### Pomp

Persaansluiting	150 mm
Diameter aanzuigzijde	150 mm
Impeller diameter	302 mm
Aantal bladen	2

#### Motor

Motor #	N3171.860 25-32-4IE-W IE3 22KW
Stator variant	2
Frequentie	50 Hz
Nominale spanning	400 V
Aantal polen	4
Fasen	3~
Nominaal vermogen	22 kW
Toegekende stroom	39 A
Aanloopstroom	288 A
Nominaal toerental	1475 rpm

Vermogensfactor	
1/1 Load	0,88
3/4 Load	0,84
1/2 Load	0,74
Motor efficiency	
1/1 Load	93,2 %
3/4 Load	93,9 %
1/2 Load	93,9 %

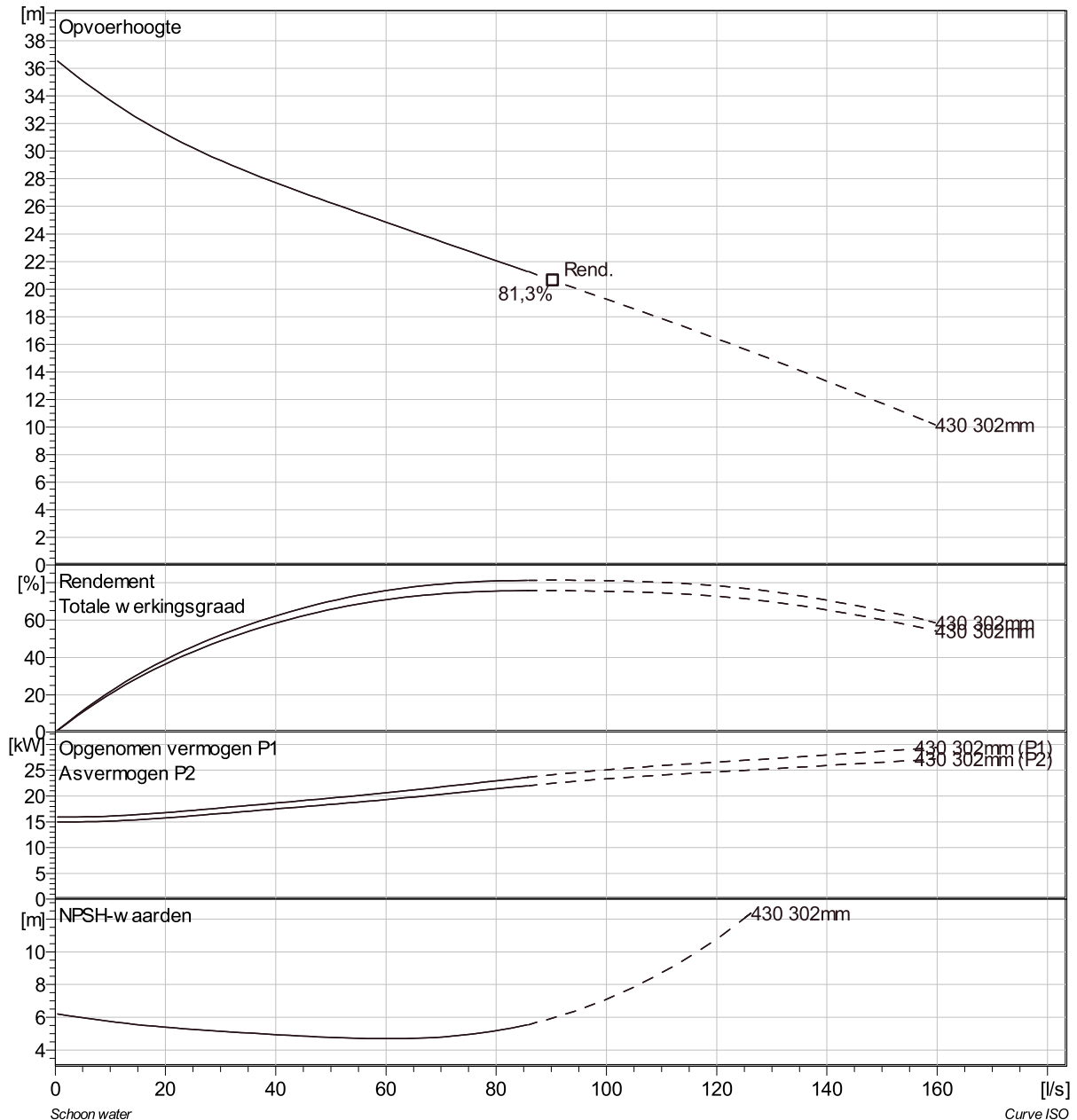

Project omschrijving	Projectnummer	Aangemaakt door:	Aangemaakt op 9/27/2018	Laatste wijziging
----------------------	---------------	------------------	----------------------------	-------------------

## NP 3171 MT 3~ 430 VFD Analysis

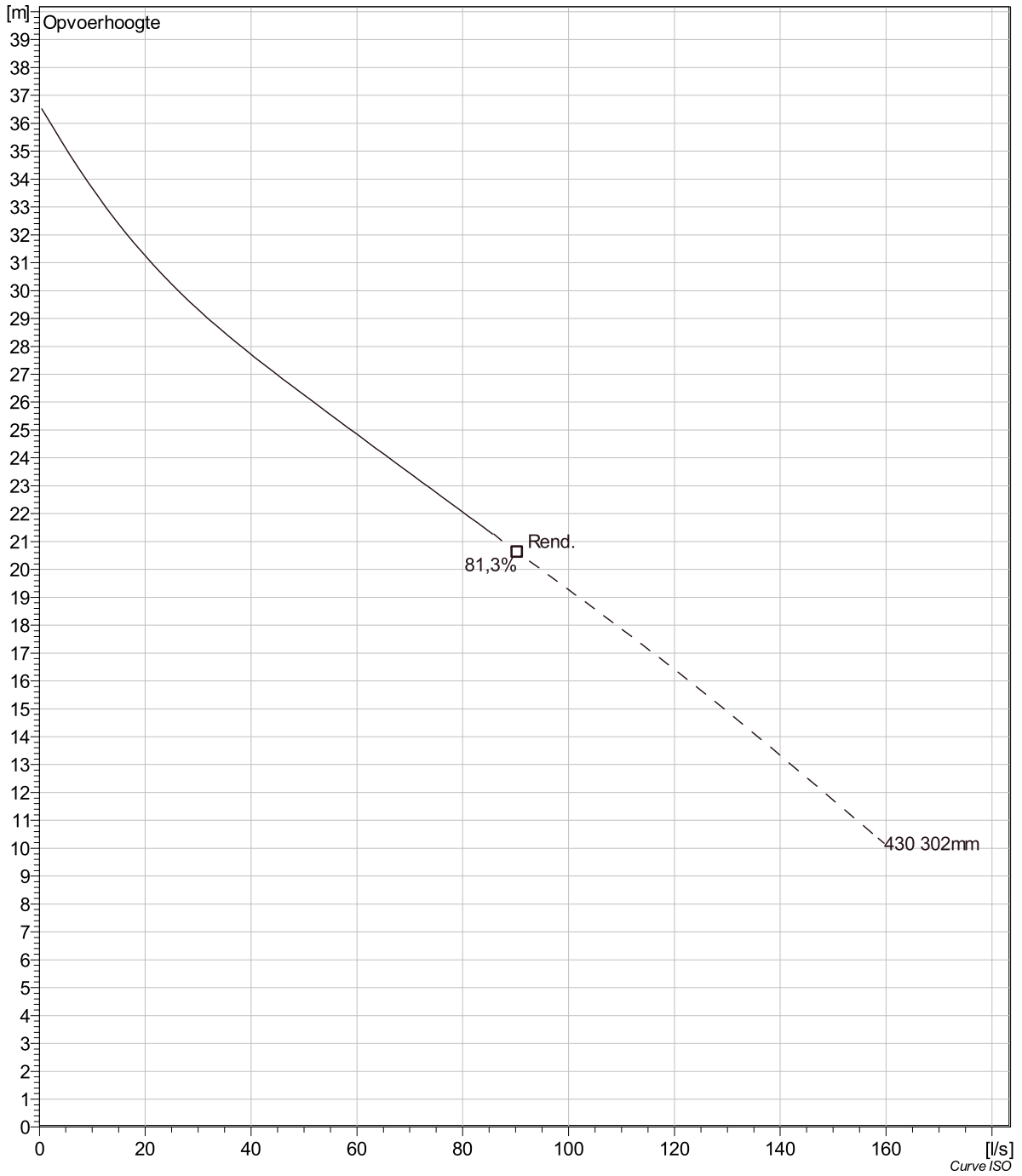

Project omschrijving	Projectnummer	Aangemaakt door:	Aangemaakt op 9/27/2018	Laatste wijziging
----------------------	---------------	------------------	----------------------------	-------------------

## NP 3171 MT 3~ 430 Dimensional drawing

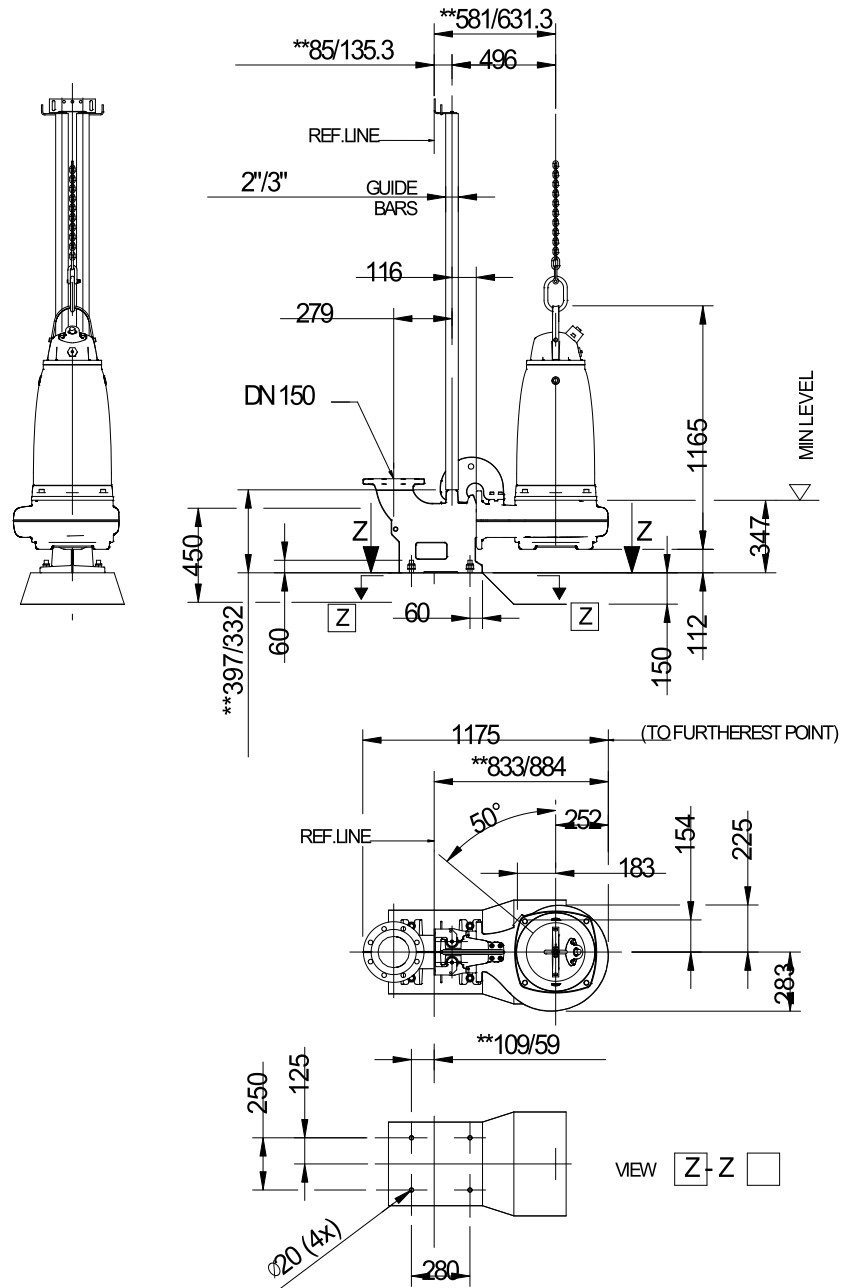

2' GUIDE BARS FOR NEW INSTALLATION  
3' GUIDE BARS FOR RETROFIT

\* DIMENSION TO ENDS OF GUIDE BARS  
\*\* DIMENSION FOR 2' / 3' GUIDE BARS

NP, FP 3171.800, 810, 820, 830, 840, 850, 860, 870  
MT

NP, FP 3171.800, 810, 820, 830, 840, 850, 860, 870 MT

Project omschrijving	Projectnummer	Aangemaakt door:	Aangemaakt op 9/27/2018	Laatste wijziging
----------------------	---------------	------------------	----------------------------	-------------------