

NS 3171 LT 3~ 613 Technische specificaties

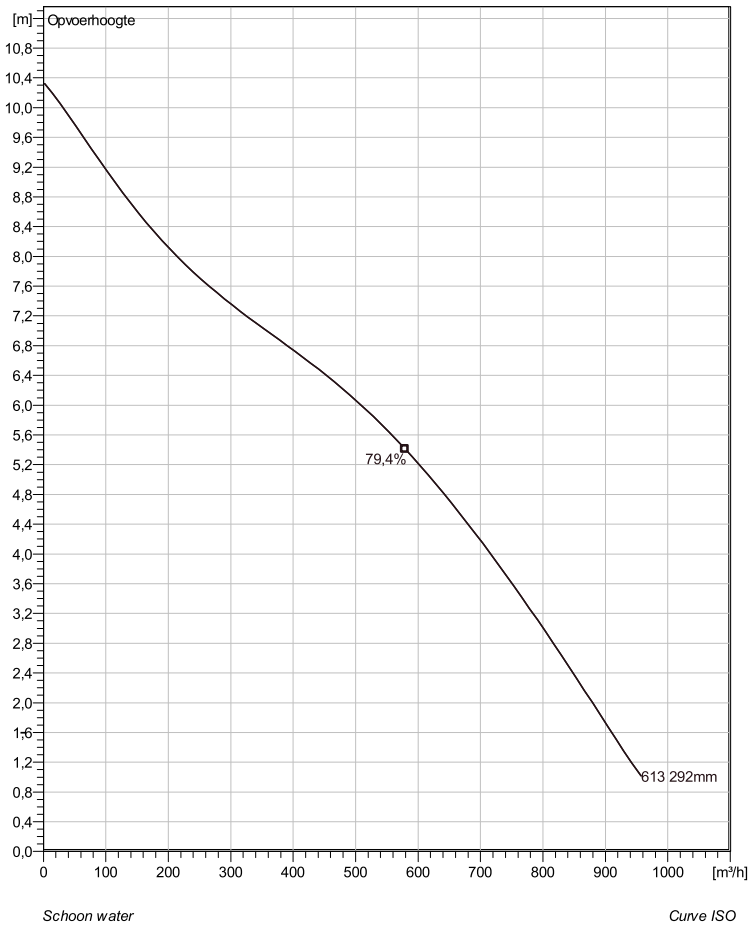

Note: Picture might not correspond to the current configuration.

General

Dompelbare pompen voorzien van een verstopingsongevoeilige N-waaiër. Geschikt voor afvalwater met grotere delen zoals rioolwater, regenwater en industriële afvalwater. Materiaal gietijzer.

Impeller

Impeller material	Grey cast iron
Persaansluiting	250 mm
Diameter aanzuigzijde	250 mm
Impeller diameter	292 mm
Aantal bladen	2

Motor

Motor #	N3171.181 25-18-6BB-W 15KW standaard
Stator variant	2
Frequentie	50 Hz
Nominale spanning	230 V
Aantal polen	6
Fasen	3~
Nominaal vermogen	15 kW
Toegekende stroom	52 A
Aanloopstroom	278 A
Nominaal toerental	965 rpm
Vermogensfactor	
1/1 Load	0,85
3/4 Load	0,80
1/2 Load	0,69
Motor efficiency	
1/1 Load	85,0 %
3/4 Load	87,0 %
1/2 Load	87,0 %

Soort installatie: Semi permanent, Nat

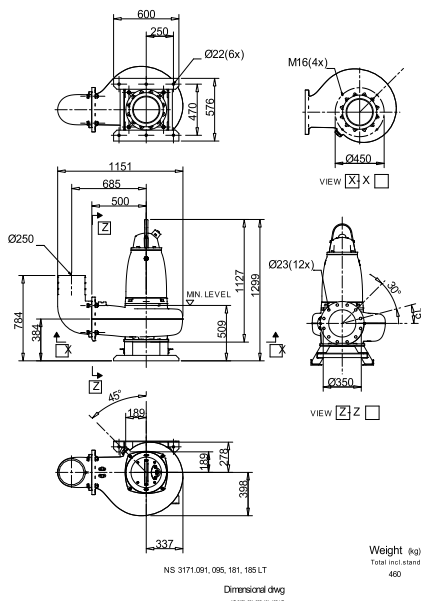

Project	Project ID	Created by	Created on 10/5/2018	Last update
---------	------------	------------	-------------------------	-------------

NS 3171 LT 3~ 613

Karakteristiek

Pomp

Persaansluiting	250 mm
Diameter aanzuigzijde	250 mm
Impeller diameter	292 mm
Aantal bladen	2

Motor

Motor #	N3171.181 25-18-6BB-W 15KW
Stator variant	2
Frequentie	50 Hz
Nominale spanning	230 V
Aantal polen	6
Fasen	3~
Nominaal vermogen	15 kW
Toegekende stroom	52 A
Aanloopstroom	278 A
Nominaal toerental	965 rpm

Vermogensfactor	
1/1 Load	0,85
3/4 Load	0,80
1/2 Load	0,69
Motor efficiency	
1/1 Load	85,0 %
3/4 Load	87,0 %
1/2 Load	87,0 %

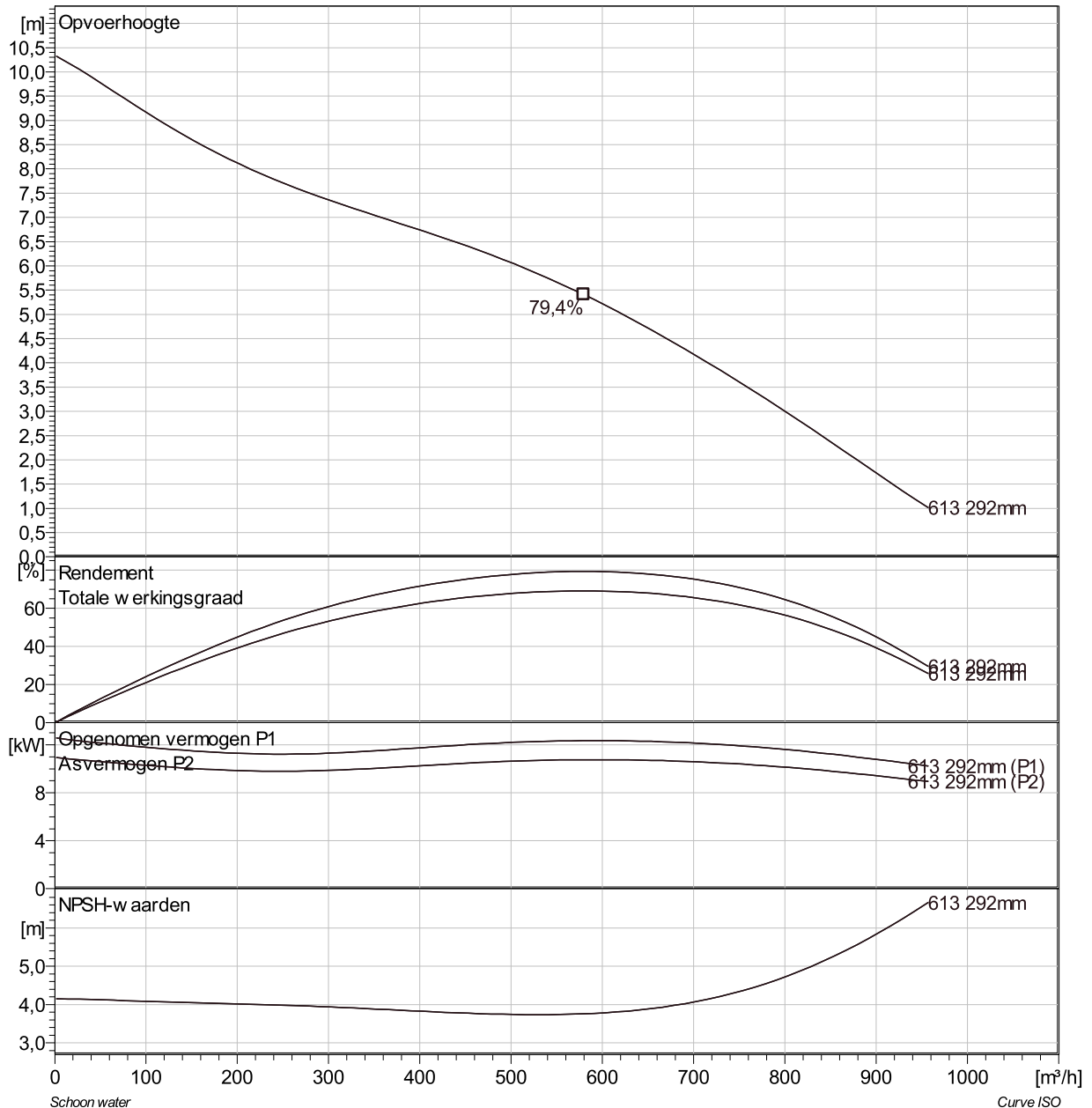

Project	Project ID	Created by	Created on 10/5/2018	Last update
---------	------------	------------	-------------------------	-------------

NS 3171 LT 3~ 613 VFD Analysis

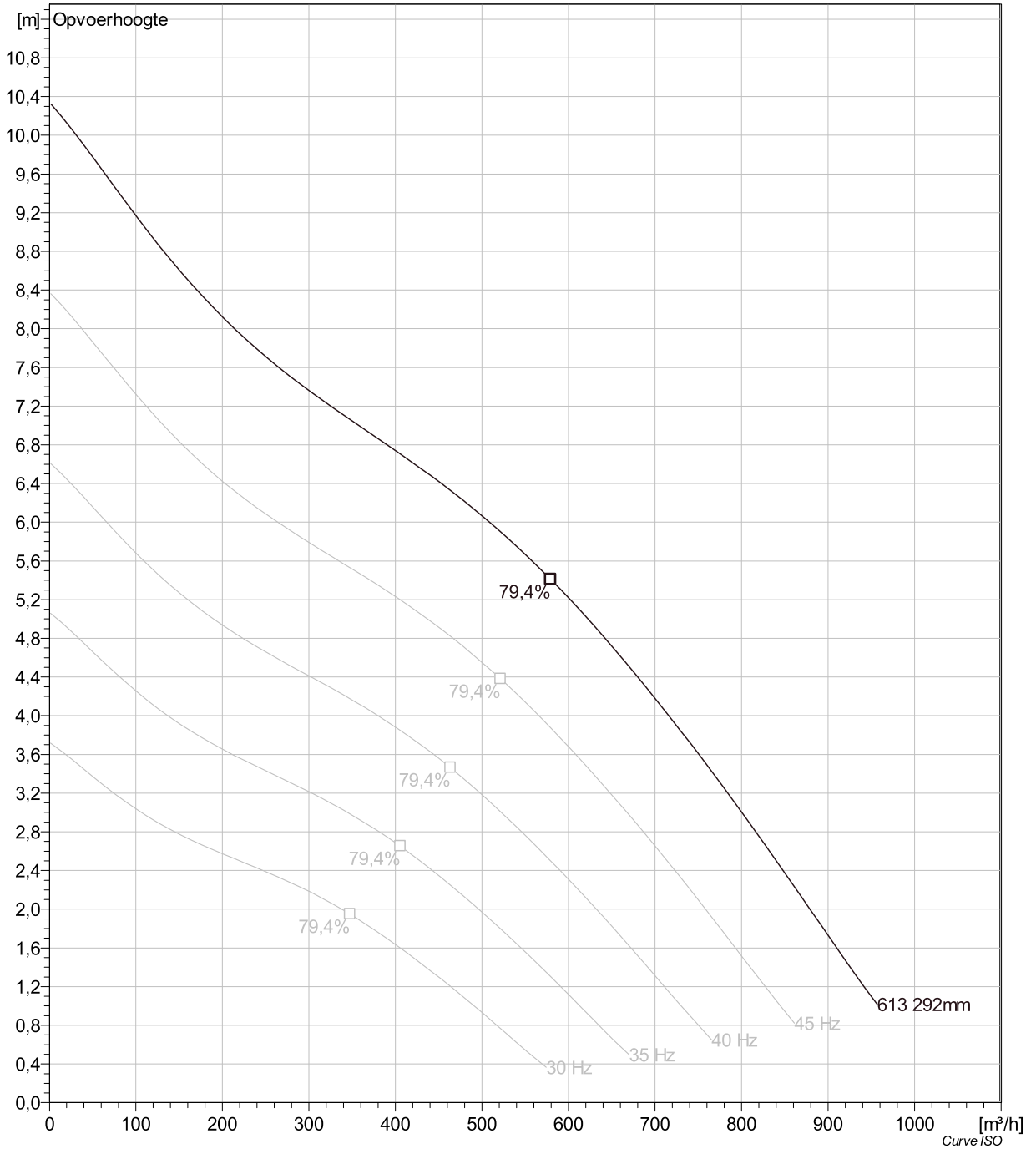

Project	Project ID	Created by	Created on	Last update
			10/5/2018	

NS 3171 LT 3~ 613 Dimensional drawing

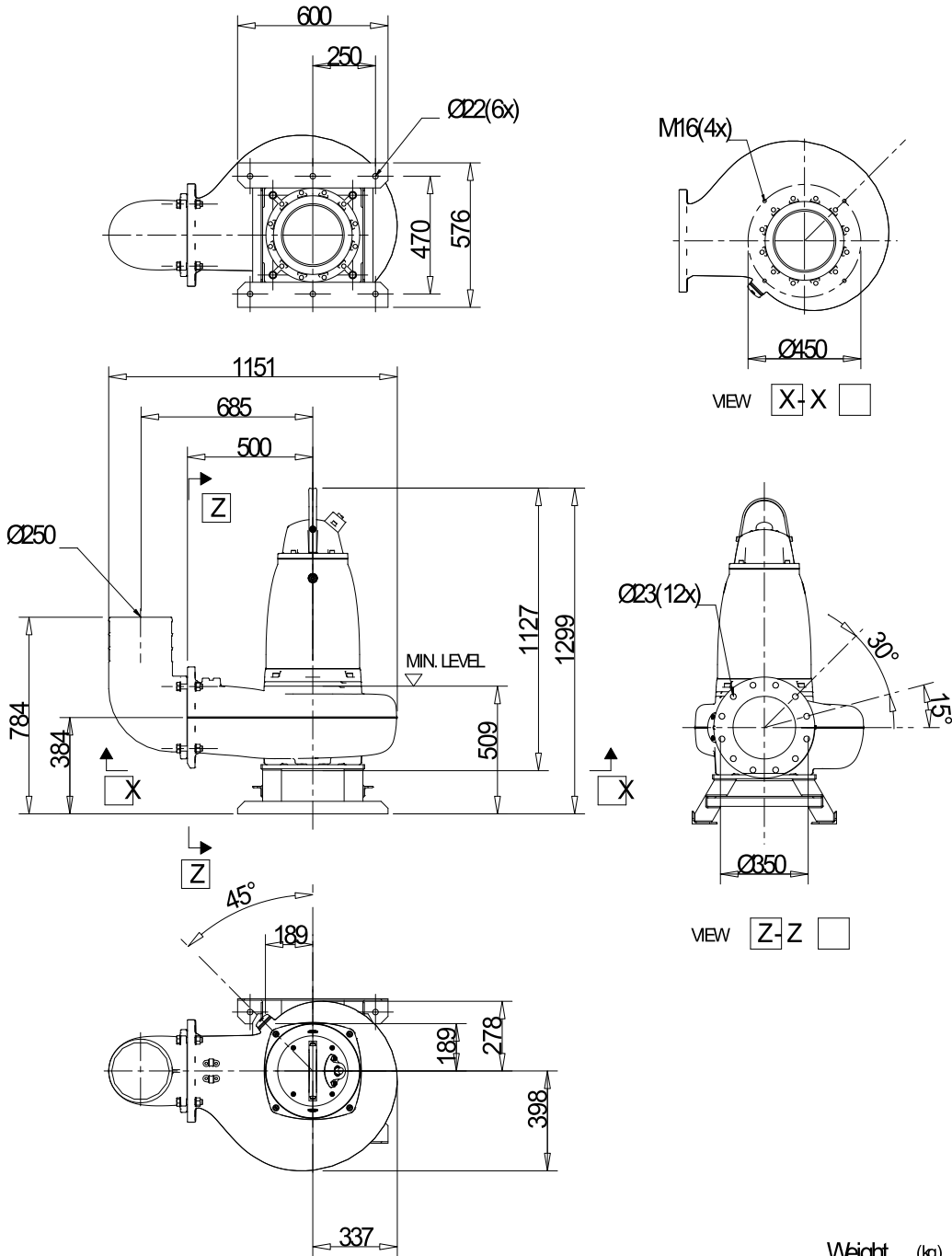

NS3171.091, 095, 181, 185LT

Weight (kg)
Total incl. stand
460

Dimensional dwg

NS3171.091,095,181,185LT

Project	Project ID	Created by	Created on	Last update
			10/5/2018	