

NS 3171 MT 3~ 432 Technische specificaties

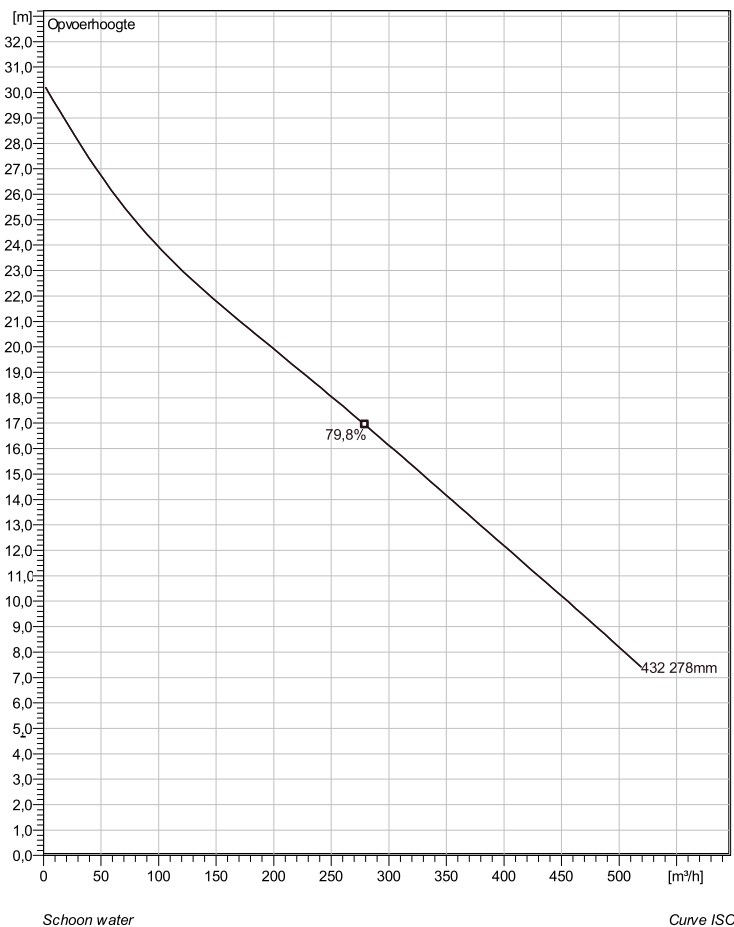

Note: Picture might not correspond to the current configuration.

General

Dompelbare pompen voorzien van verstopponsgevoelige N-waaiers. Geschikt voor afvalwater met grotere delen zoals rioolwater, regenwater en industriële afvalwater. Materiaal gietijzer.

Impeller

Impeller materiaal	Grey cast iron
Persaansluiting	150 mm
Diameter aanzuigzijde	150 mm
Impeller diameter	278 mm
Aantal bladen	2

Motor

Motor #	N3171.181 25-19-4AA-W 22KW standaard
Stator variant	2
Frequentie	50 Hz
Nominale spanning	230 V
Aantal polen	4
Fasen	3~
Nominaal vermogen	22 kW
Toegekende stroom	73 A
Aanlooptroom	470 A
Nominaal toerental	1460 rpm
Vermogensfactor	
1/1 Load	0,86
3/4 Load	0,80
1/2 Load	0,70
Motor efficiency	
1/1 Load	88,5 %
3/4 Load	89,5 %
1/2 Load	90,0 %

Soort installatie: Semi permanent, Nat

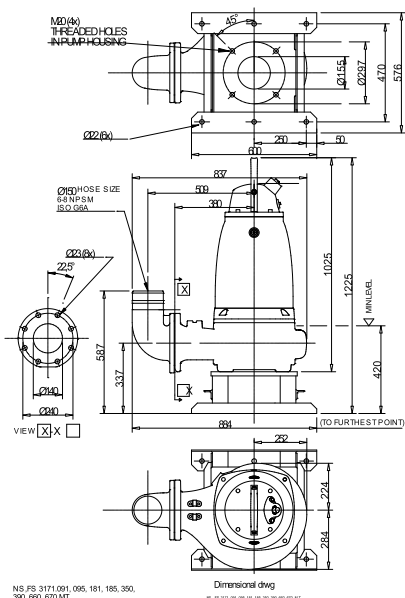

Project	Project ID	Created by	Created on 10/5/2018	Last update
---------	------------	------------	-------------------------	-------------

NS 3171 MT 3~ 432

Karakteristiek

Pomp

Persaansluiting	150 mm
Diameter aanzuigzijde	150 mm
Impeller diameter	278 mm
Aantal bladen	2

Motor

Motor #	N3171.181 25-19-4AA-W 22KW
Stator variant	2
Frequentie	50 Hz
Nominale spanning	230 V
Aantal polen	4
Fasen	3~
Nominaal vermogen	22 kW
Toegekende stroom	73 A
Aanloopstroom	470 A
Nominaal toerental	1460 rpm

Vermogensfactor	
1/1 Load	0,86
3/4 Load	0,80
1/2 Load	0,70
Motor efficiency	
1/1 Load	88,5 %
3/4 Load	89,5 %
1/2 Load	90,0 %

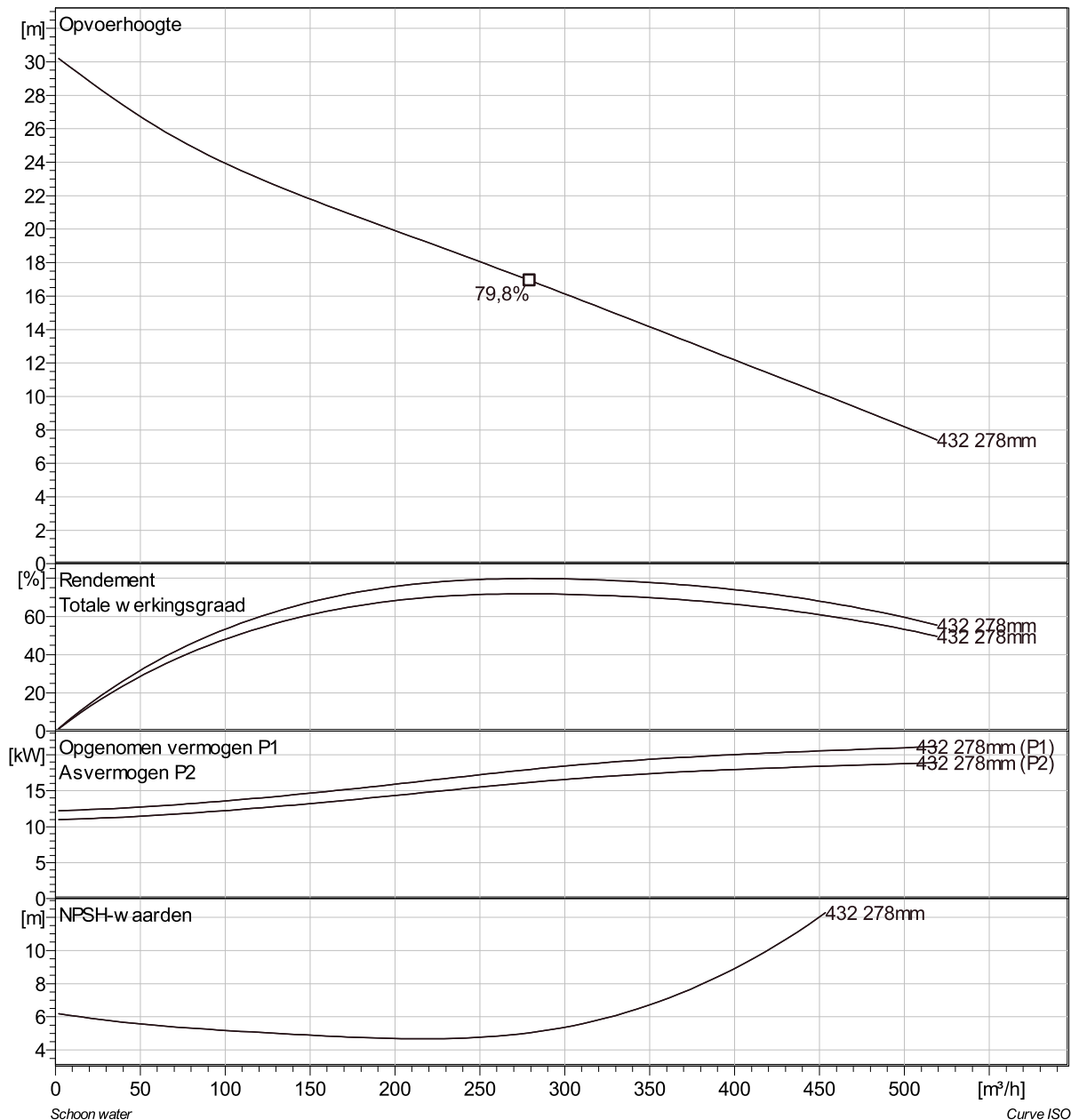

Project	Project ID	Created by	Created on 10/5/2018	Last update
---------	------------	------------	-------------------------	-------------

NS 3171 MT 3~ 432 VFD Analysis

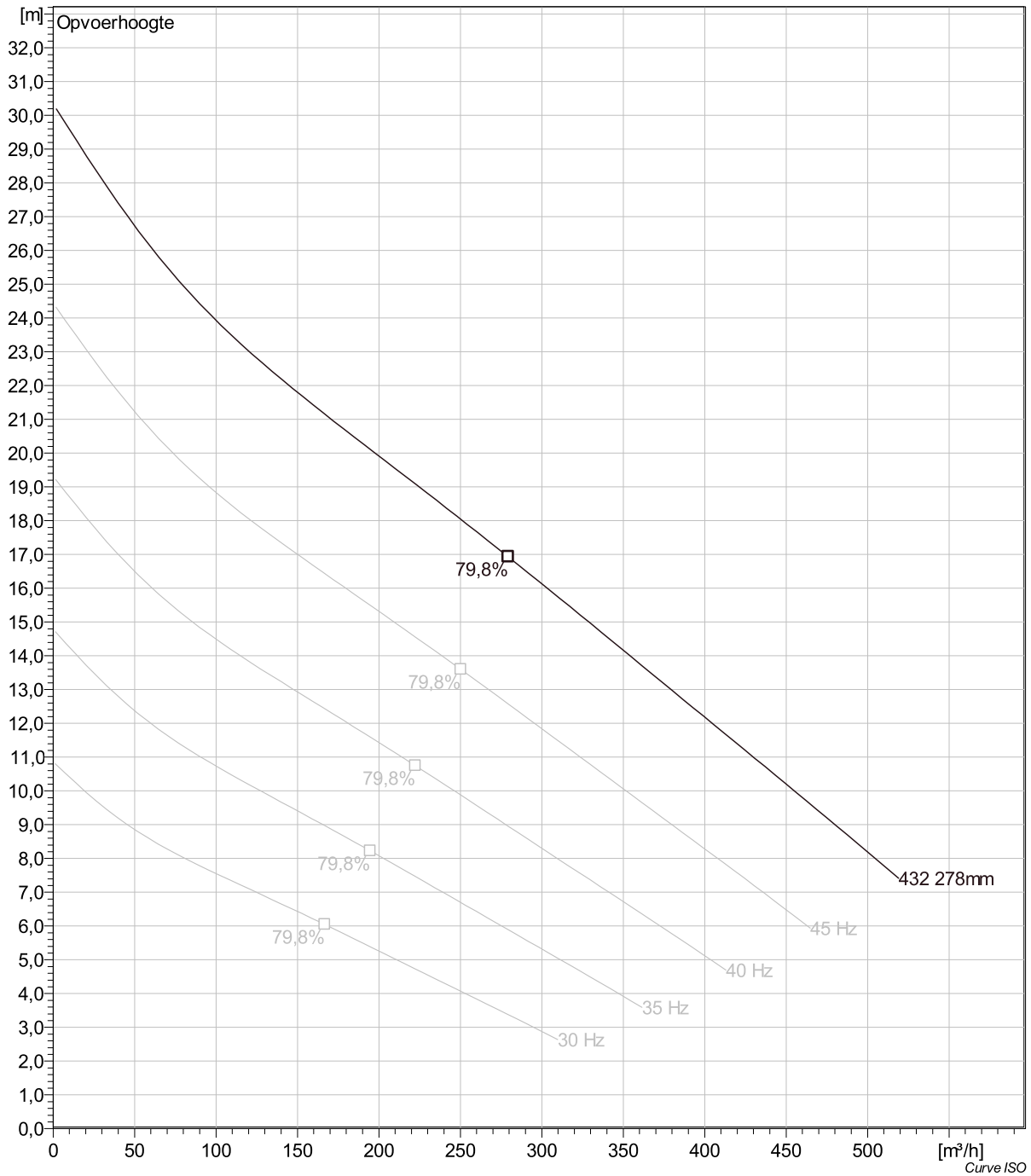

Project	Project ID	Created by	Created on	Last update
			10/5/2018	

NS 3171 MT 3~ 432 Dimensional drawing

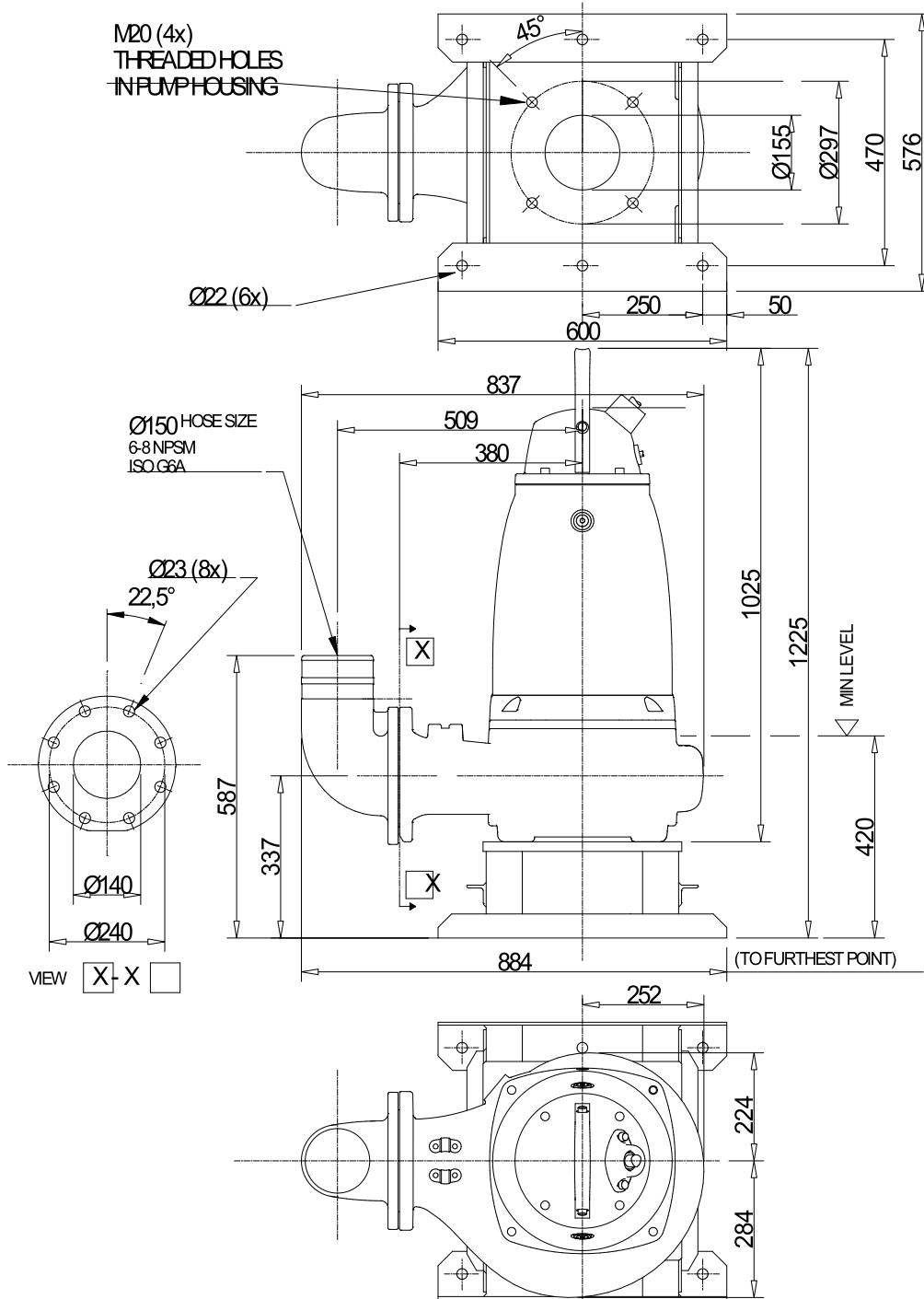

NS,FS 3171.091,095,181,185,350,390,660,670
MT

Dimensional drwg

NS, FS 3171.091,095,181,185,350,390,660,670/MT

Project	Project ID	Created by	Created on	Last update
			10/5/2018	