

NP 3202 HT 3~ 452 Technische specificaties

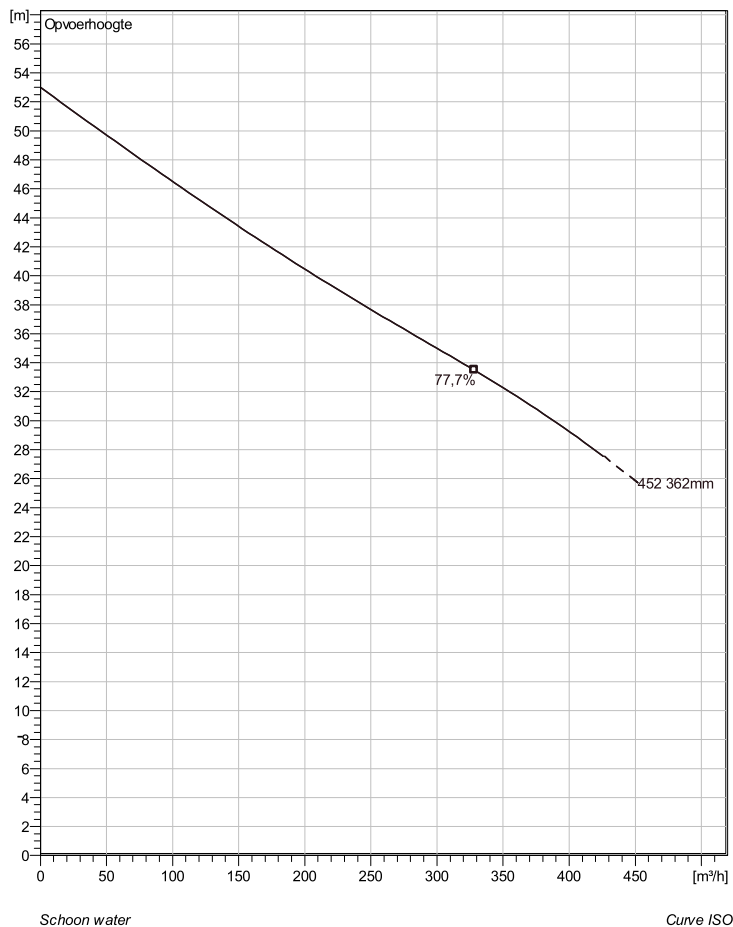

Note: Picture might not correspond to the current configuration.

General

Dompelbare pompen voorzien van verstopingsongevoeelige N-waaiers. Geschikt voor afvalwater met grotere delen zoals rioolwater, regenwater en industriële afvalwater. Materiaal gietijzer.

Impeller

Impeller material	Grey cast iron
Persaansluiting	150 mm
Diameter aanzuigzijde	200 mm
Impeller diameter	362 mm
Aantal bladen	2

Motor

Motor #	N3202.180 30-29-4AA-W 45KW standaard
Stator variant	1
Frequentie	50 Hz
Nominale spanning	400 V
Aantal polen	4
Fasen	3~
Nominaal vermogen	45 kW
Toegekende stroom	79 A
Aanlooptroom	540 A
Nominaal toerental	1475 rpm
Vermogensfactor	
1/1 Load	0,90
3/4 Load	0,86
1/2 Load	0,78
Motor efficiency	
1/1 Load	92,0 %
3/4 Load	93,0 %
1/2 Load	93,0 %

Soort installatie: Semi Permanent, Nat

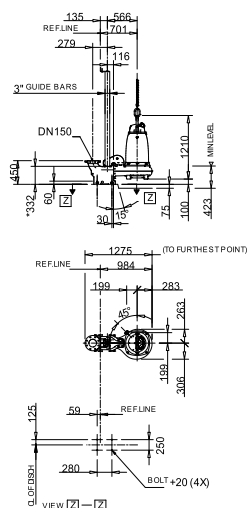

* DIMENSION TO ENDS OF GUIDE BARS

EP: NP 3202.090, 095, 180, 185, 350, 390 HT

Dimensional dwg

Project omschrijving	Projectnummer	Aangemaakt door:	Aangemaakt op 9/27/2018	Laatste wijziging
----------------------	---------------	------------------	----------------------------	-------------------

NP 3202 HT 3~ 452

Karakteristiek

Pomp

Persaansluiting	150 mm
Diameter aanzuigzijde	200 mm
Impeller diameter	362 mm
Aantal bladen	2

Motor

Motor #	N3202.180 30-29-4AA-W 45KW
Stator variant	1
Frequentie	50 Hz
Nominale spanning	400 V
Aantal polen	4
Fasen	3~
Nominaal vermogen	45 kW
Toegekende stroom	79 A
Aanloopstroom	540 A
Nominaal toerental	1475 rpm

Vermogensfactor	
1/1 Load	0,90
3/4 Load	0,86
1/2 Load	0,78
Motor efficiency	
1/1 Load	92,0 %
3/4 Load	93,0 %
1/2 Load	93,0 %

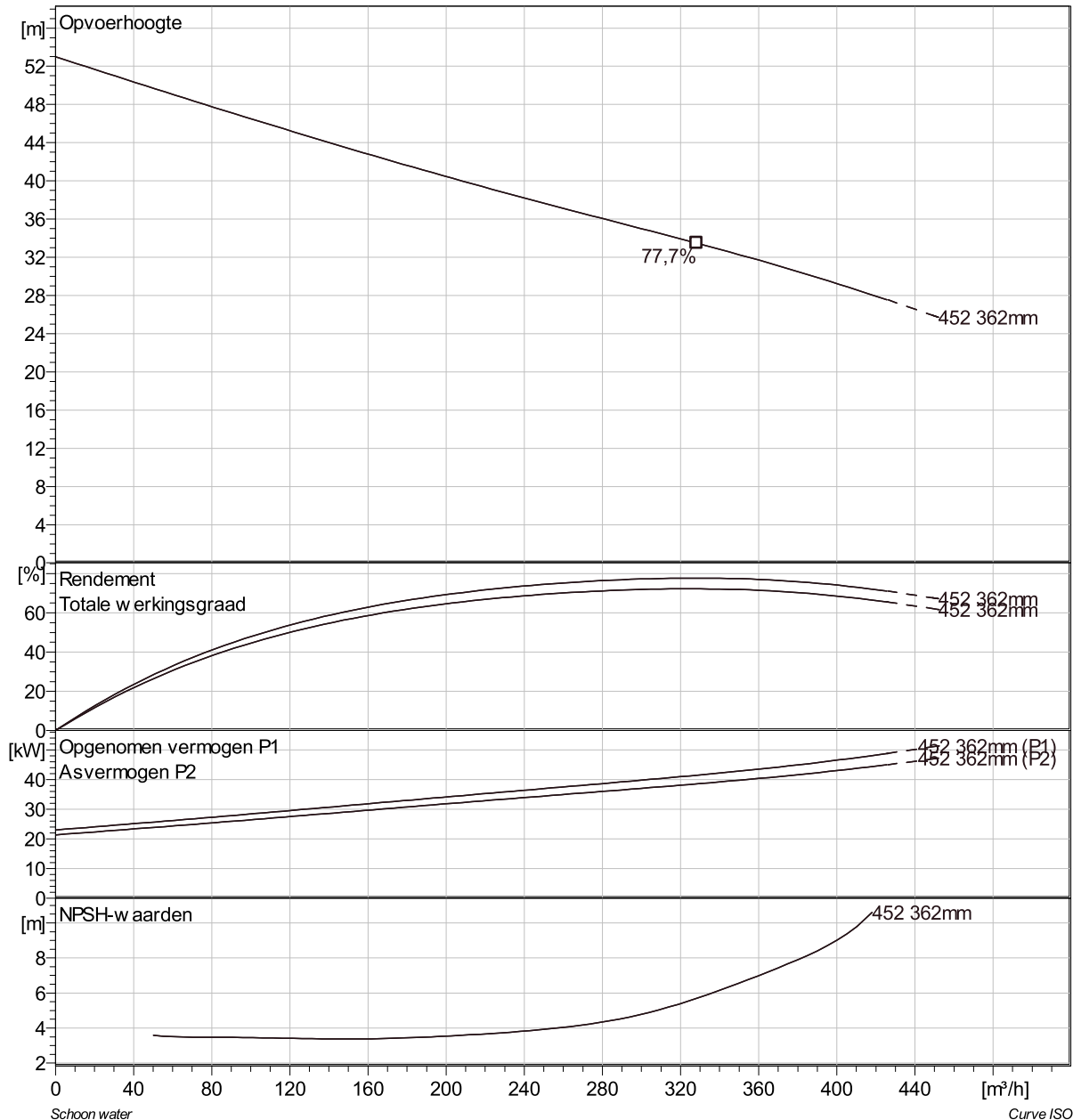

Project omschrijving	Projectnummer	Aangemaakt door:	Aangemaakt op 9/27/2018	Laatste wijziging
----------------------	---------------	------------------	----------------------------	-------------------

NP 3202 HT 3~ 452 VFD Analysis

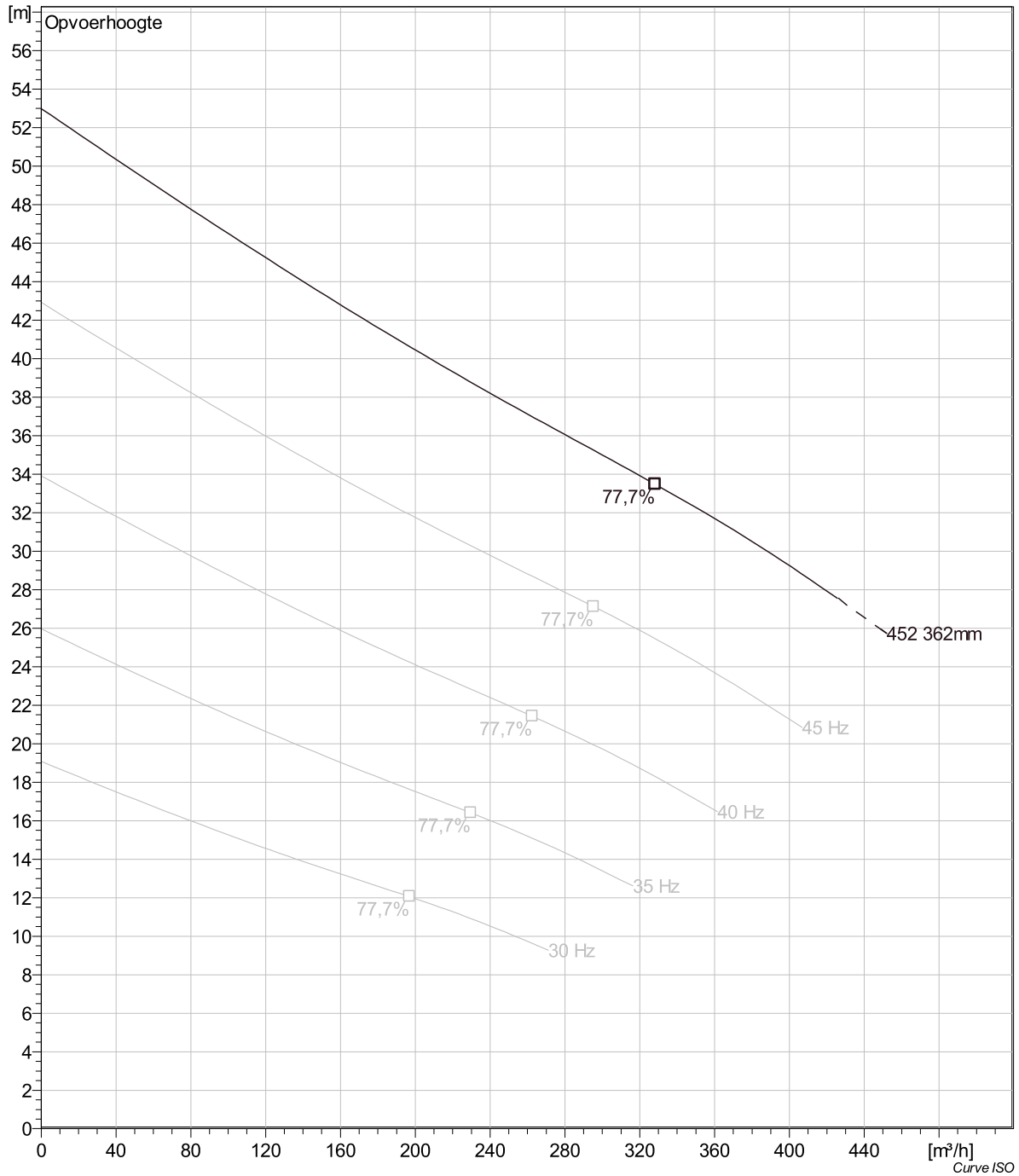

Project omschrijving	Projectnummer	Aangemaakt door:	Aangemaakt op 9/27/2018	Laatste wijziging
----------------------	---------------	------------------	----------------------------	-------------------

NP 3202 HT 3~ 452 Dimensional drawing

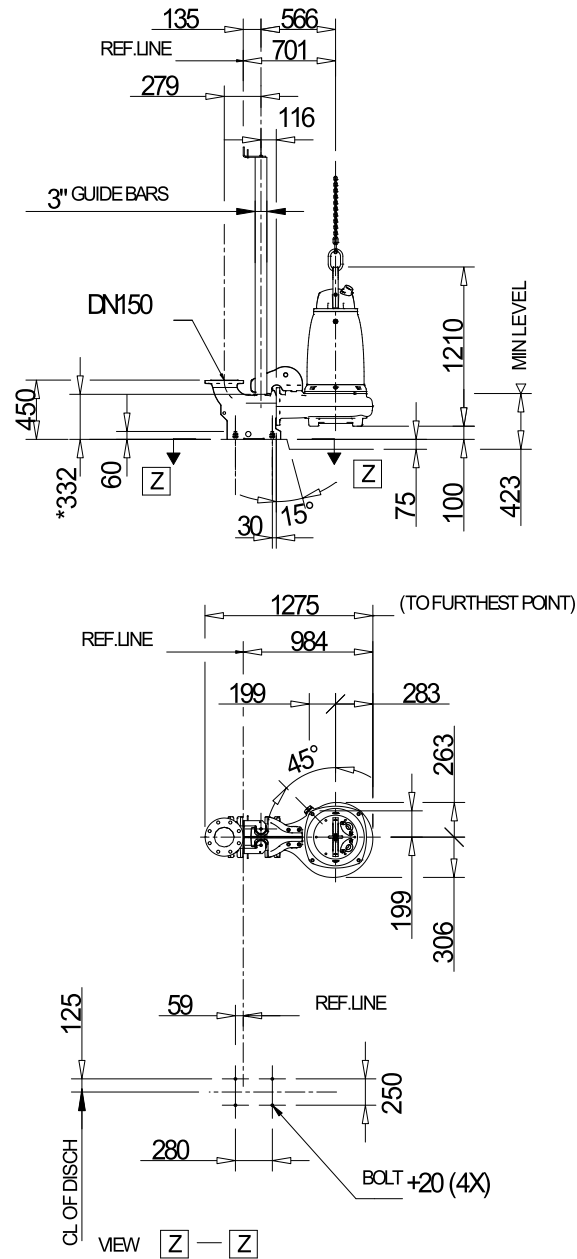

* DIMENSION TO ENDS OF GUIDE BARS

FP, NP 3202.090, 095, 180, 185, 350, 390 HT

Dimensional dwg

FPNP 3202.090,095,180,185,350,390 HT

Project omschrijving	Projectnummer	Aangemaakt door:	Aangemaakt op 9/27/2018	Laatste wijziging
----------------------	---------------	------------------	----------------------------	-------------------