

NP 3202 LT 3~ 615 Technische specificaties

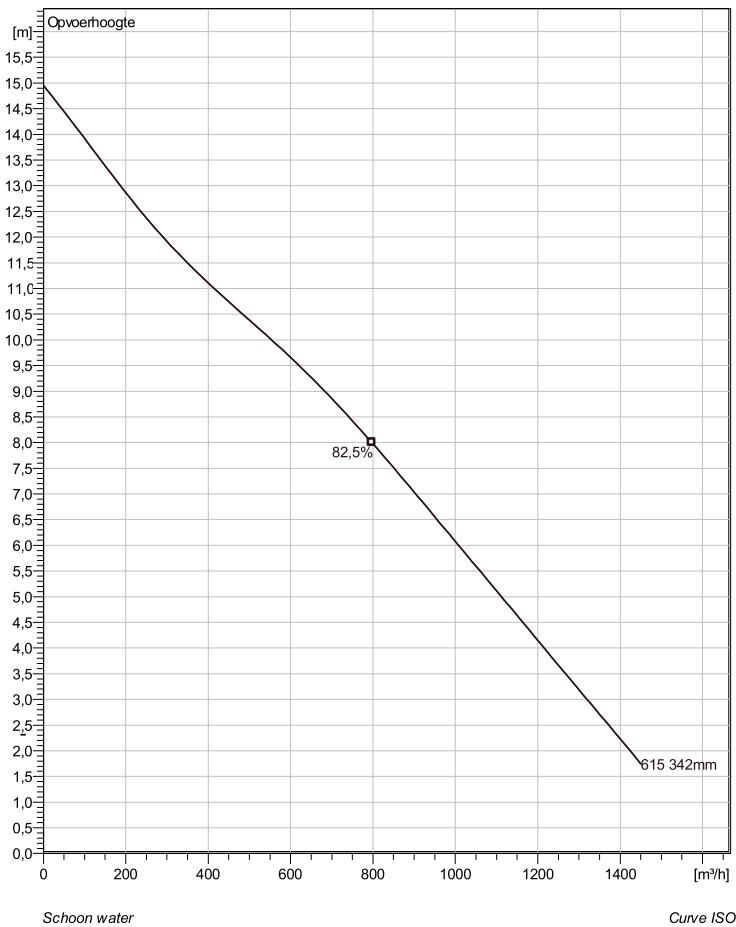

Note: Picture might not correspond to the current configuration.

General

Dompelbare pompen voorzien van verstopponsgevoelige N-waaiers. Geschikt voor afvalwater met grotere delen zoals rioolwater, regenwater en industriële afvalwater. Materiaal gietijzer.

Impeller

Impeller material	Grey cast iron
Persaansluiting	300 mm
Diameter aanzuigzijde	300 mm
Impeller diameter	342 mm
Aantal bladen	2
Throughlet diameter	92 mm

Motor

Motor #	N3202.180 30-18-6AA-W 22KW standaard
Stator variant	1
Frequentie	50 Hz
Nominale spanning	400 V
Aantal polen	6
Fasen	3~
Nominaal vermogen	22 kW
Toegekende stroom	43 A
Aanloopstroom	238 A
Nominaal toerental	970 rpm
Vermogensfactor	
1/1 Load	0,84
3/4 Load	0,80
1/2 Load	0,70
Motor efficiency	
1/1 Load	88,5 %
3/4 Load	89,5 %
1/2 Load	89,0 %

Soort installatie: Semi Permanent, Nat

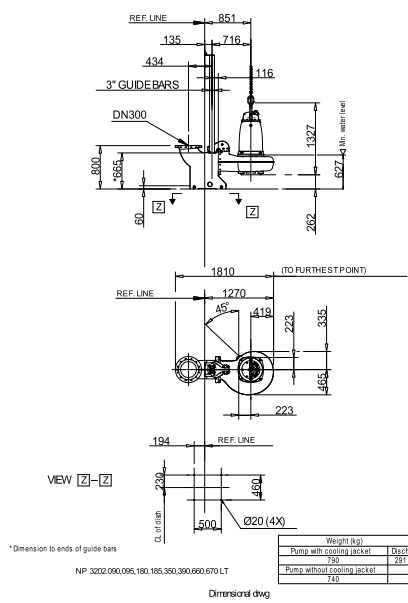

Project omschrijving	Projectnummer	Aangemaakt door:	Aangemaakt op 9/27/2018	Laatste wijziging
----------------------	---------------	------------------	----------------------------	-------------------

NP 3202 LT 3~ 615

Karakteristiek

Pomp

Persaansluiting	300 mm
Diameter aanzuigzijde	300 mm
Impeller diameter	342 mm
Aantal bladen	2
Throughlet diameter	92 mm

Motor

Motor #	N3202.180 30-18-6AA-W 22KW
Stator variant	1
Frequentie	50 Hz
Nominale spanning	400 V
Aantal polen	6
Fasen	3~
Nominaal vermogen	22 kW
Toegekende stroom	43 A
Aanloopstroom	238 A
Nominaal toerental	970 rpm

Vermogensfactor	
1/1 Load	0,84
3/4 Load	0,80
1/2 Load	0,70
Motor efficiency	
1/1 Load	88,5 %
3/4 Load	89,5 %
1/2 Load	89,0 %

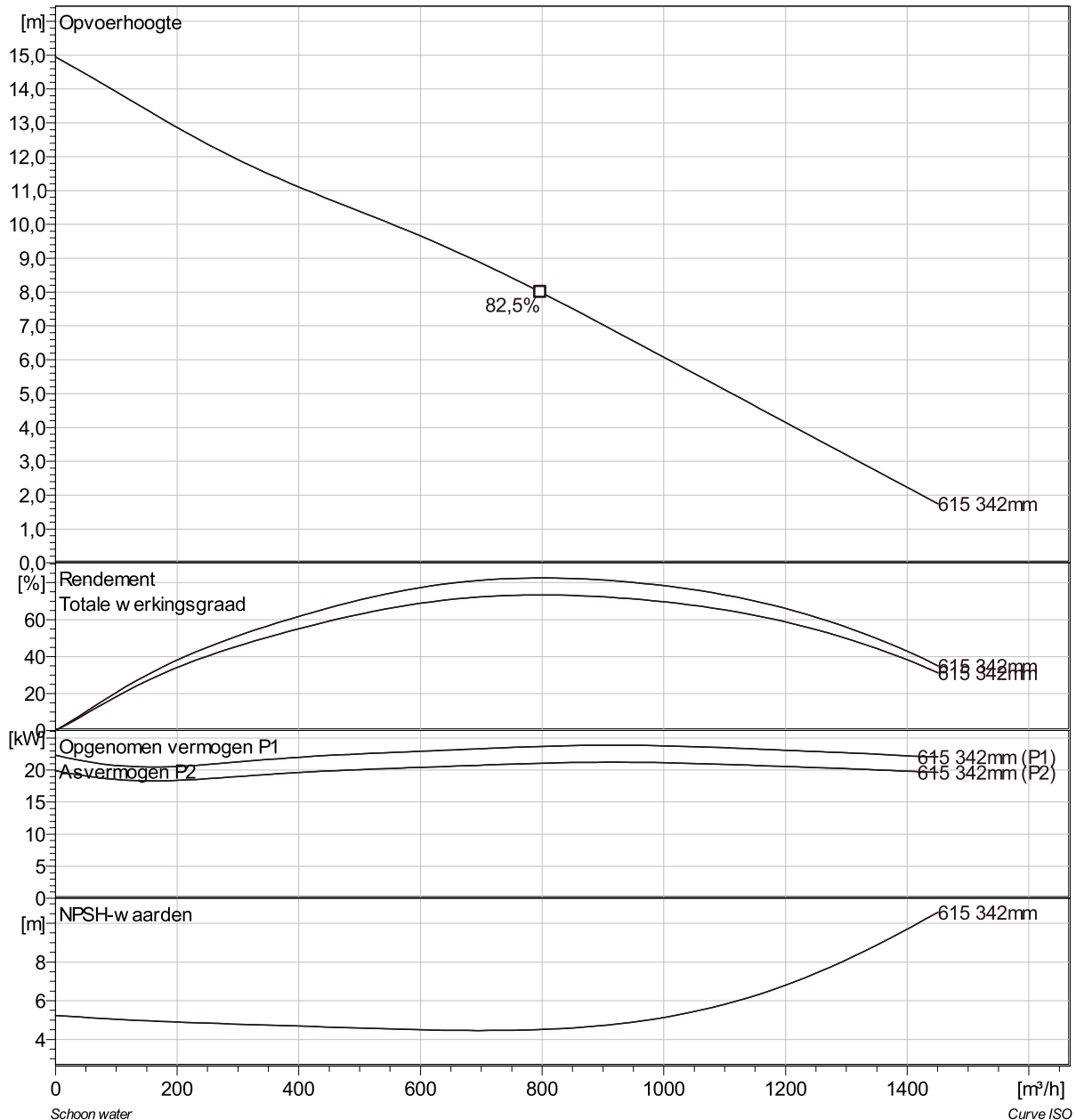

Project omschrijving	Projectnummer	Aangemaakt door:	Aangemaakt op 9/27/2018	Laatste wijziging
----------------------	---------------	------------------	----------------------------	-------------------

NP 3202 LT 3~ 615 VFD Analysis

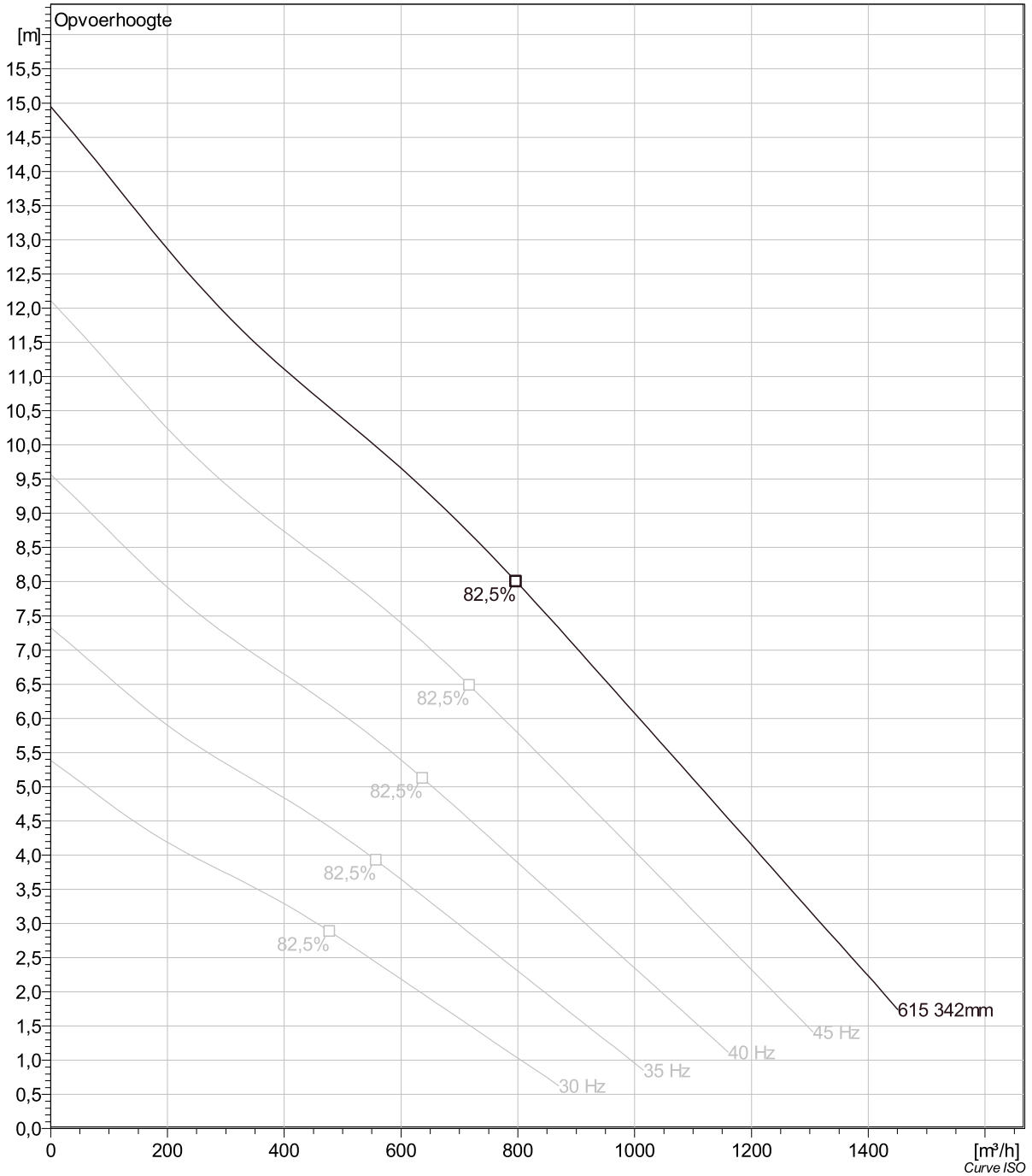

Project omschrijving	Projectnummer	Aangemaakt door:	Aangemaakt op 9/27/2018	Laatste wijziging
----------------------	---------------	------------------	----------------------------	-------------------

NP 3202 LT 3~ 615 Dimensional drawing

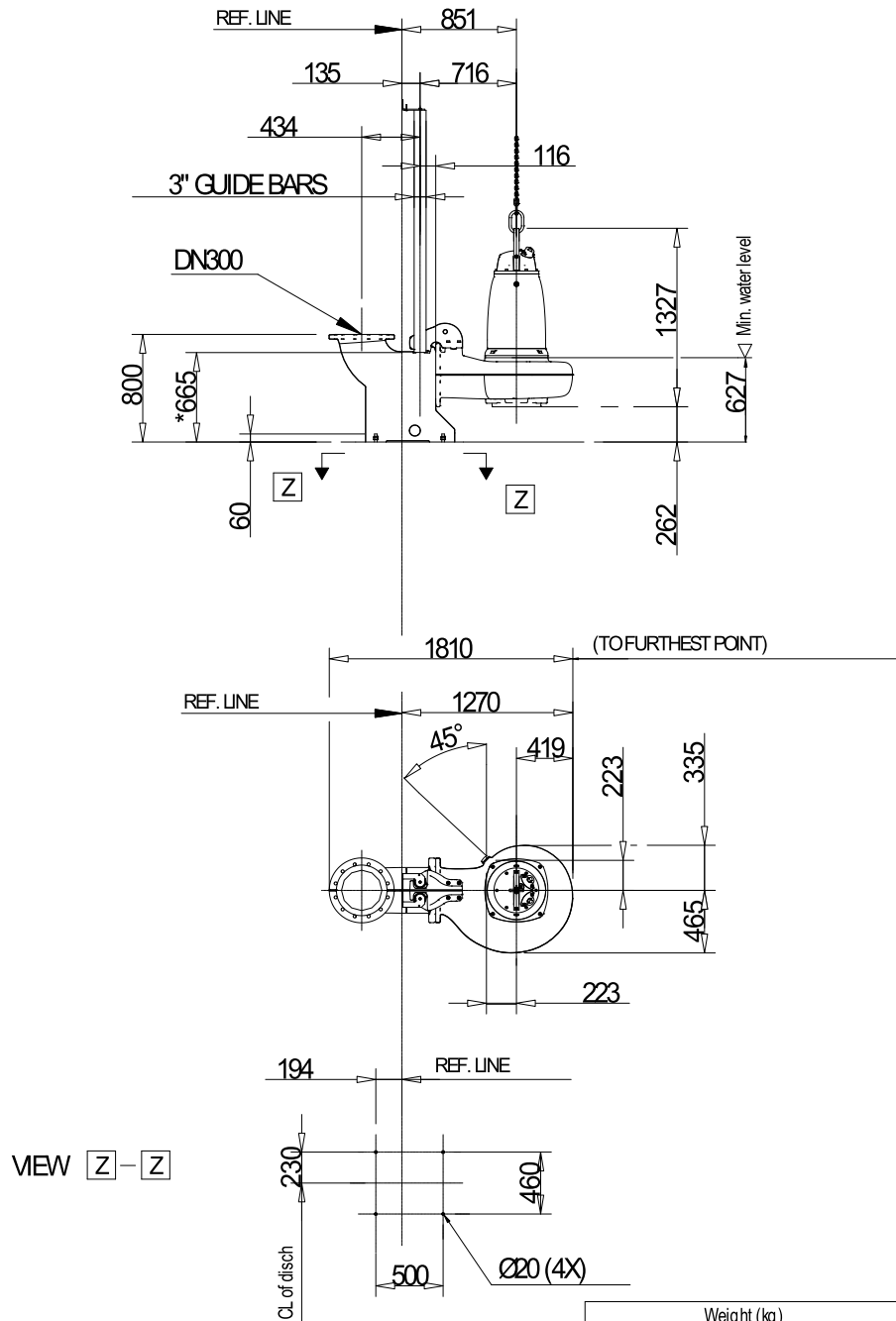

* Dimension to ends of guide bars

NP 3202,090,095,180,185,350,390,660,670 LT

Weight (kg)	
Pump with cooling jacket	Disch
790	291
Pump without cooling jacket	
740	

Dimensional dwg

NP 3202,090,095,180,185,350,390,660,670 LT

Project omschrijving	Projectnummer	Aangemaakt door:	Aangemaakt op 9/27/2018	Laatste wijziging
----------------------	---------------	------------------	----------------------------	-------------------