

NP 3202 MT 3~ 640 Technische specificaties

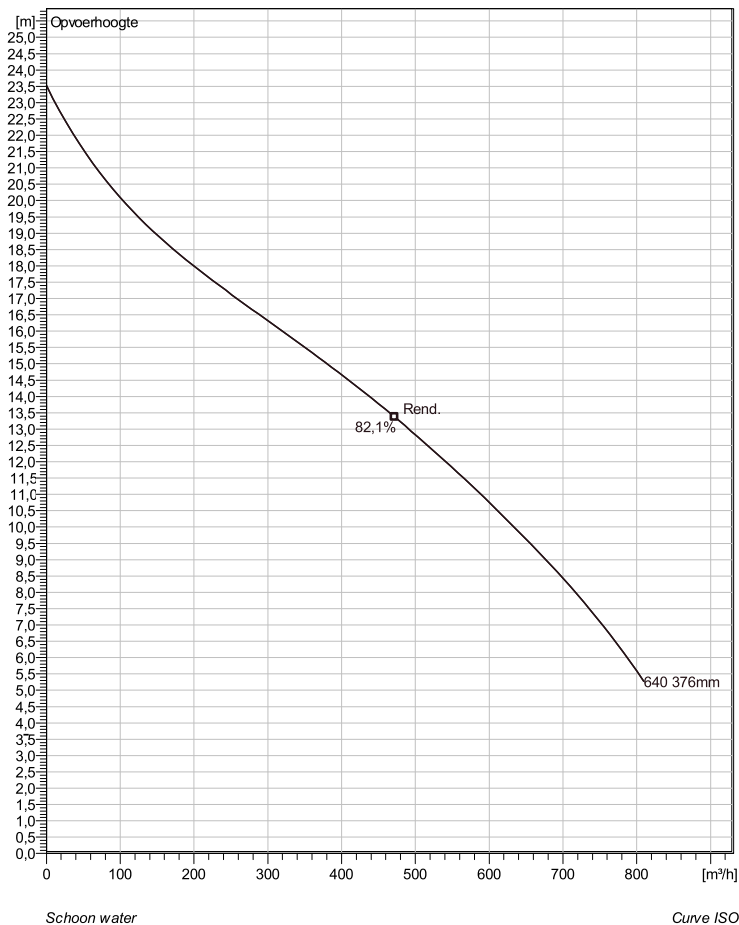

Note: Picture might not correspond to the current configuration.

General

Dompelbare pompen voorzien van een verstopingsongevoeilige N-waaiër. Geschikt voor afvalwater met grotere delen zoals rioolwater, regenwater en industriële afvalwater. Materiaal gietijzer.

Impeller

Impeller material	Grey cast iron
Persaansluiting	200 mm
Diameter aanzuigzijde	250 mm
Impeller diameter	376 mm
Aantal bladen	2

Motor

Motor #	N3202.180 30-23-6AA-W 30KW standaard
Stator variant	1
Frequentie	50 Hz
Nominale spanning	380 V
Aantal polen	6
Fasen	3~
Nominaal vermogen	30 kW
Toegekende stroom	59 A
Aanloopstroom	300 A
Nominaal toerental	970 rpm
Vermogensfactor	
1/1 Load	0,87
3/4 Load	0,84
1/2 Load	0,76
Motor efficiency	
1/1 Load	88,5 %
3/4 Load	89,5 %
1/2 Load	90,0 %

Soort installatie: Semi Permanent, Nat

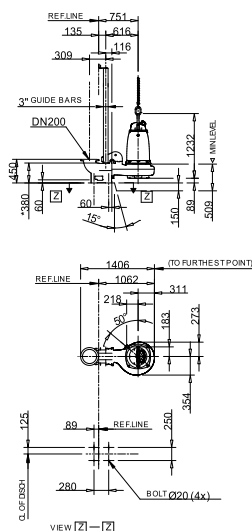

Only for 6 poles.

* DIMENSION TO ENDS OF GUIDE BARS

FP: NP 3202 050, 065, 180, 185, 350, 380, 650, 670 MT

Dimensional dwg

Project omschrijving	Projectnummer	Aangemaakt door:	Aangemaakt op 9/27/2018	Laatste wijziging
----------------------	---------------	------------------	----------------------------	-------------------

NP 3202 MT 3~ 640

Karakteristiek

Pomp

Persaansluiting	200 mm
Diameter aanzuigzijde	250 mm
Impeller diameter	376 mm
Aantal bladen	2

Motor

Motor #	N3202.180 30-23-6AA-W 30KW
Stator variant	1
Frequentie	50 Hz
Nominale spanning	380 V
Aantal polen	6
Fasen	3~
Nominaal vermogen	30 kW
Toegekende stroom	59 A
Aanloopstroom	300 A
Nominaal toerental	970 rpm

Vermogensfactor	
1/1 Load	0,87
3/4 Load	0,84
1/2 Load	0,76
Motor efficiency	
1/1 Load	88,5 %
3/4 Load	89,5 %
1/2 Load	90,0 %

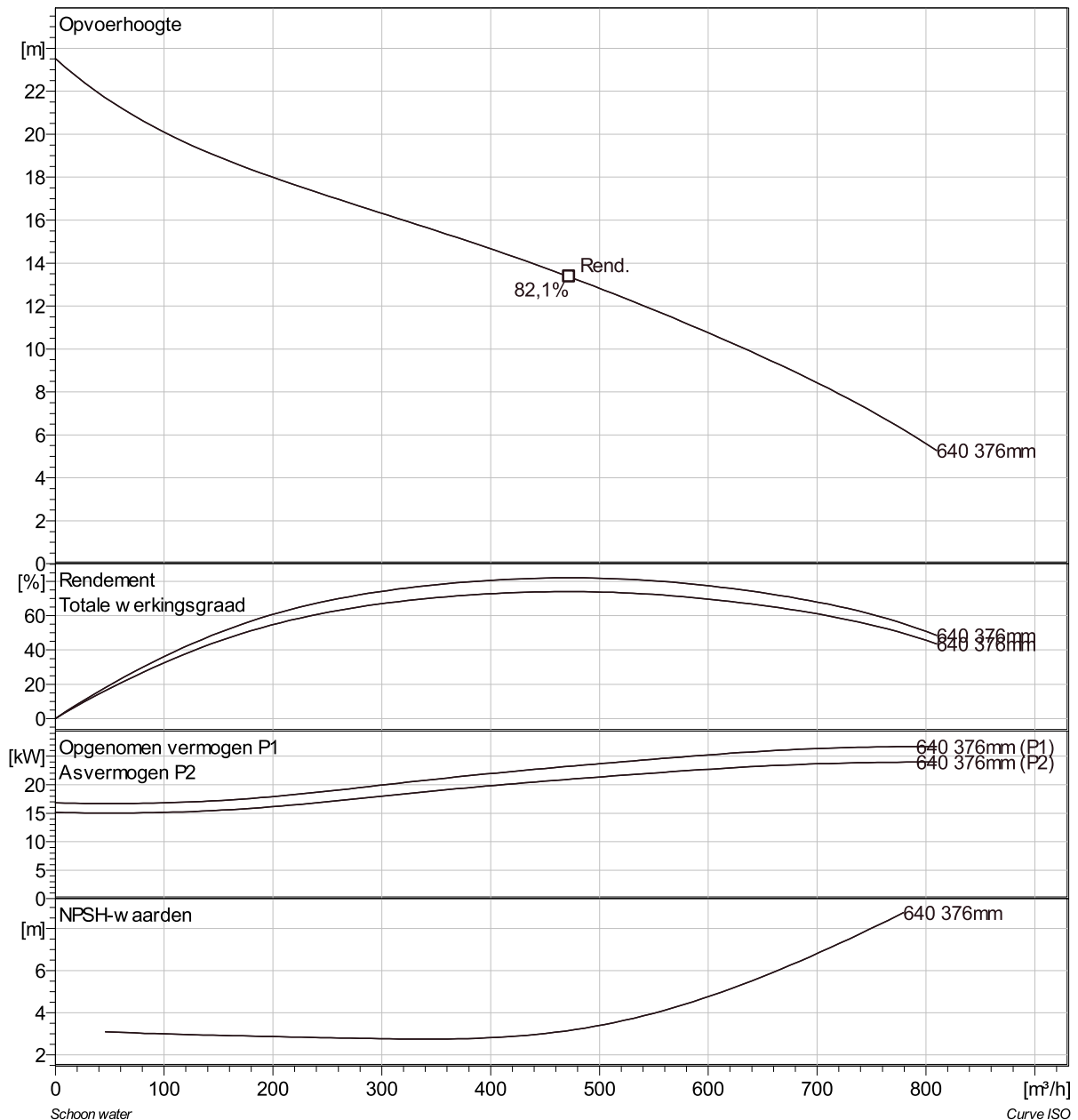

Project omschrijving	Projectnummer	Aangemaakt door:	Aangemaakt op 9/27/2018	Laatste wijziging
----------------------	---------------	------------------	----------------------------	-------------------

NP 3202 MT 3~ 640 VFD Analysis

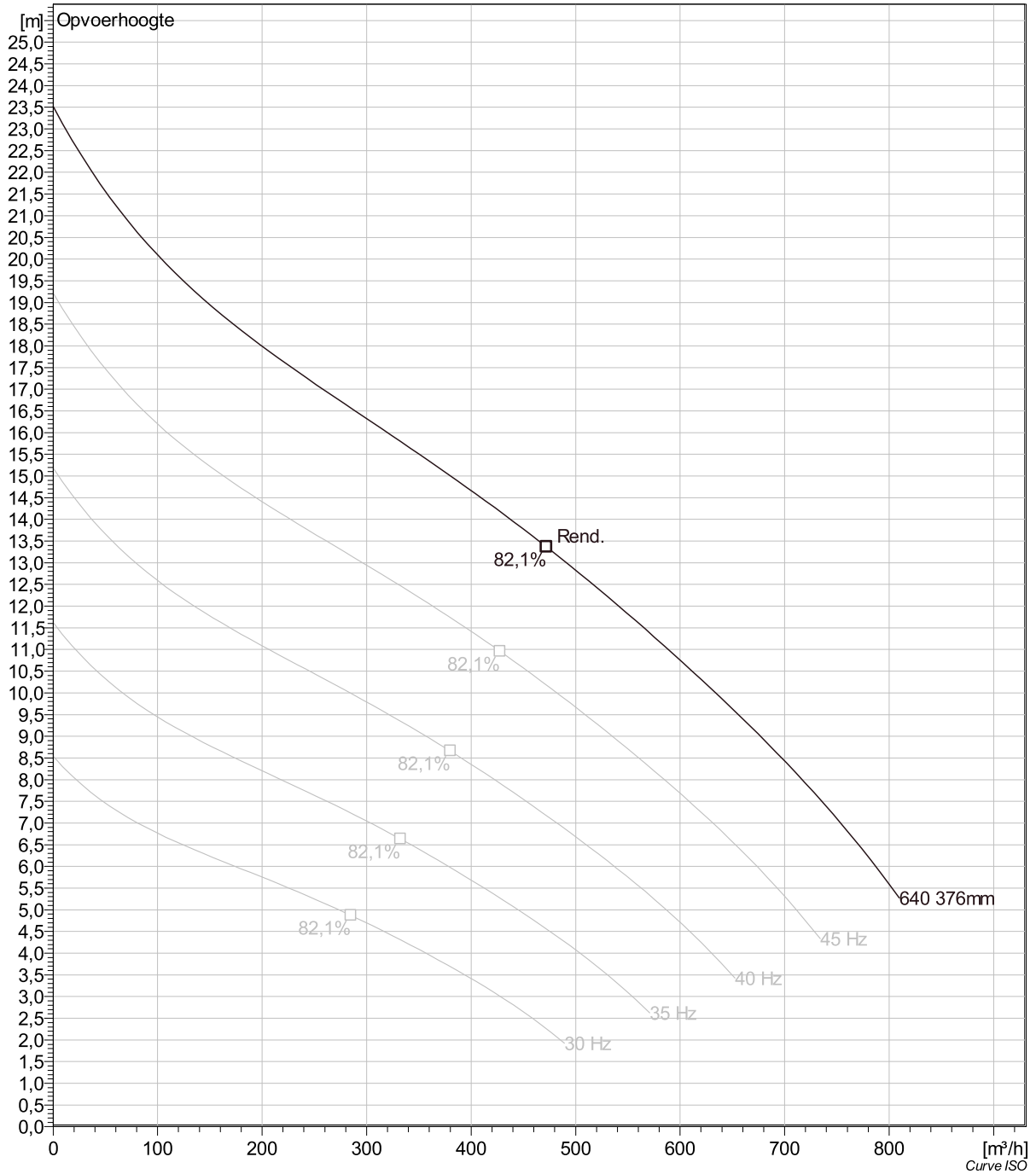

Project omschrijving	Projectnummer	Aangemaakt door:	Aangemaakt op 9/27/2018	Laatste wijziging
----------------------	---------------	------------------	----------------------------	-------------------

NP 3202 MT 3~ 640 Dimensional drawing

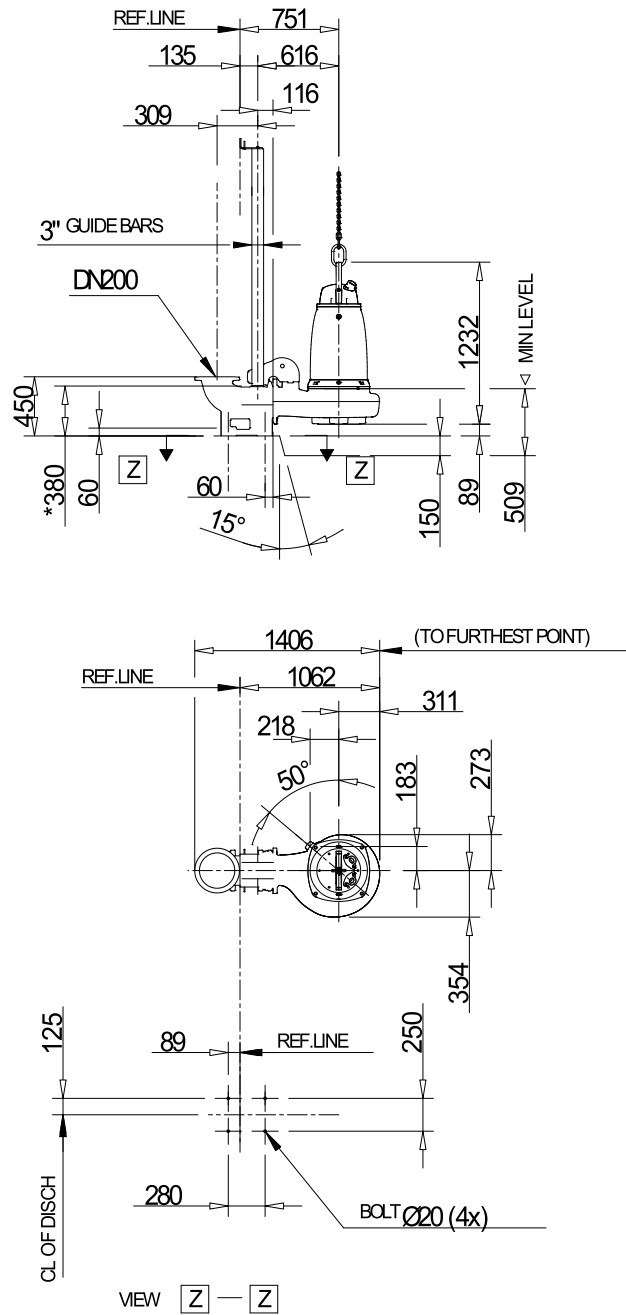

Only for 6-poles.

* DIMENSION TO ENDS OF GUIDE BARS

FP, NP 3202.090, 095, 180, 185, 350, 390, 660, 670 MT

Dimensional dwg

FP, NP 3202.090, 095, 180, 185, 350, 390, 660, 670 MT

Project omschrijving	Projectnummer	Aangemaakt door:	Aangemaakt op 9/27/2018	Laatste wijziging
----------------------	---------------	------------------	----------------------------	-------------------