

NP 3202 SH 3~ 272

Technische specificaties

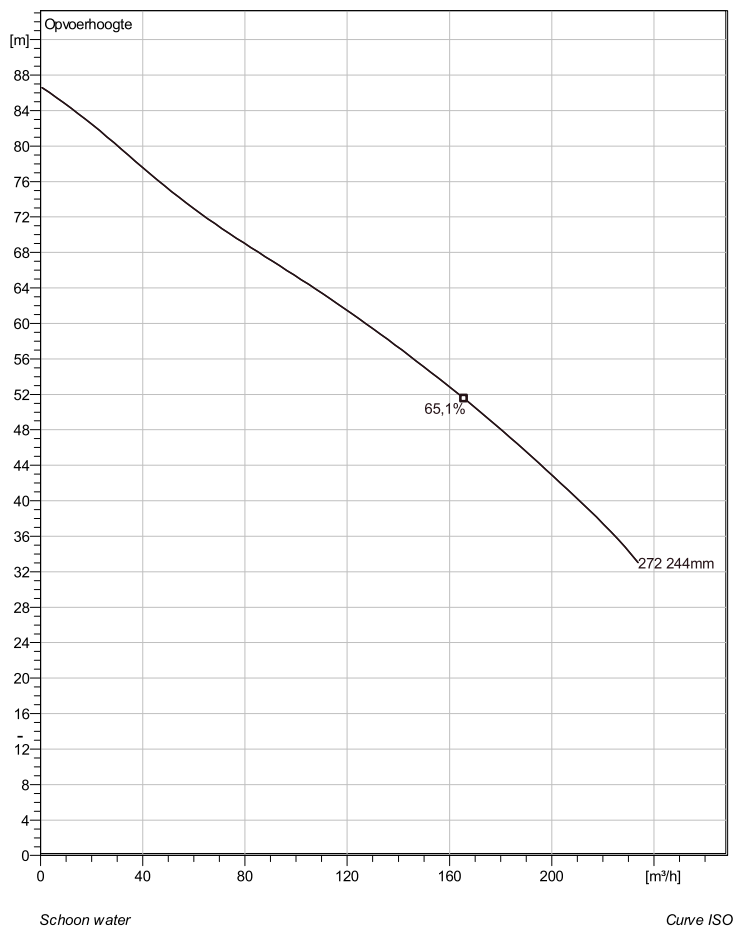

Note: Picture might not correspond to the current configuration.

General

Dompelbare pompen voorzien van een verstoppingsongevoeilige N-waaiër. Geschikt voor afvalwater met grotere delen zoals rioolwater, regenwater en industriële afvalwater. Materiaal gietijzer.

Impeller

Impeller materiaal	Hard-Iron
Persaansluiting	100 mm
Diameter aanzuigzijde	150 mm
Impeller diameter	244 mm
Aantal bladen	2

Motor

Motor #	N3202.185 30-27-2AA-W 47KW standaard
Stator variant	1
Frequentie	50 Hz
Nominale spanning	380 V
Aantal polen	2
Fasen	3~
Nominaal vermogen	47 kW
Toegekende stroom	83 A
Aanloopstroom	525 A
Nominaal toerental	2945 rpm
Vermogensfactor	
1/1 Load	0,94
3/4 Load	0,93
1/2 Load	0,90
Motor efficiency	
1/1 Load	92,0 %
3/4 Load	93,0 %
1/2 Load	93,0 %

Soort installatie: Semi Permanent, Nat

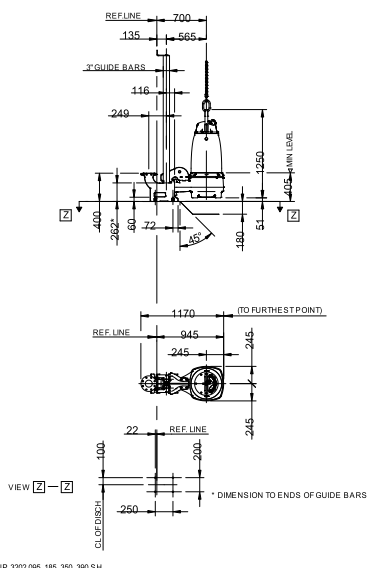

Project omschrijving	Projectnummer	Aangemaakt door:	Aangemaakt op 9/27/2018	Laatste wijziging
----------------------	---------------	------------------	----------------------------	-------------------

NP 3202 SH 3~ 272

Karakteristiek

Pomp

Persaansluiting	100 mm
Diameter aanzuigzijde	150 mm
Impeller diameter	244 mm
Aantal bladen	2

Motor

Motor #	N3202.185 30-27-2AA-W 47KW
Stator variant	1
Frequentie	50 Hz
Nominale spanning	380 V
Aantal polen	2
Fasen	3~
Nominaal vermogen	47 kW
Toegekende stroom	83 A
Aanloopstroom	525 A
Nominaal toerental	2945 rpm

Vermogensfactor	
1/1 Load	0,94
3/4 Load	0,93
1/2 Load	0,90
Motor efficiency	
1/1 Load	92,0 %
3/4 Load	93,0 %
1/2 Load	93,0 %

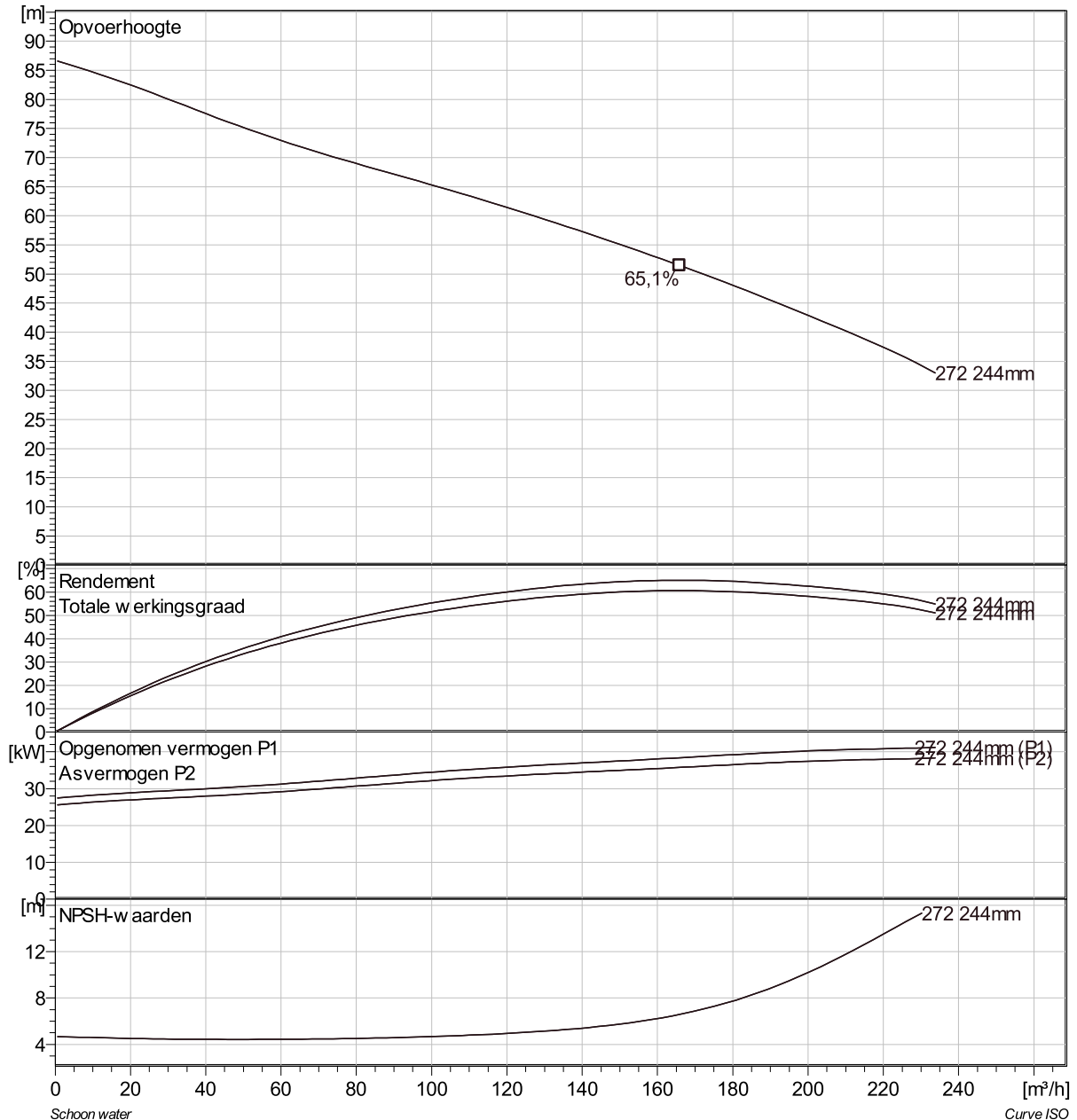

Project omschrijving	Projectnummer	Aangemaakt door:	Aangemaakt op 9/27/2018	Laatste wijziging
----------------------	---------------	------------------	----------------------------	-------------------

NP 3202 SH 3~ 272 VFD Analysis

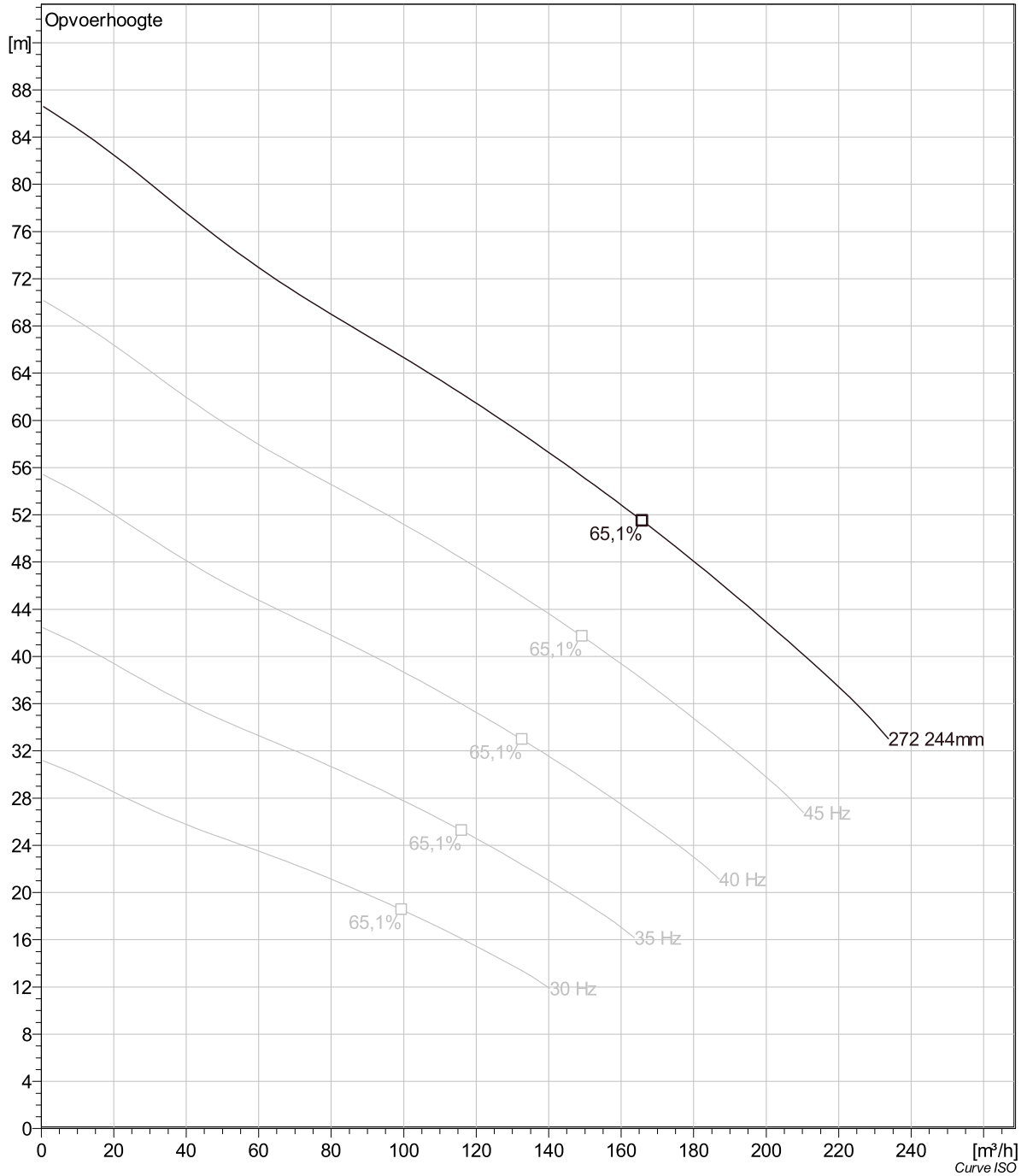

Project omschrijving	Projectnummer	Aangemaakt door:	Aangemaakt op 9/27/2018	Laatste wijziging
----------------------	---------------	------------------	----------------------------	-------------------

NP 3202 SH 3~ 272 Dimensional drawing

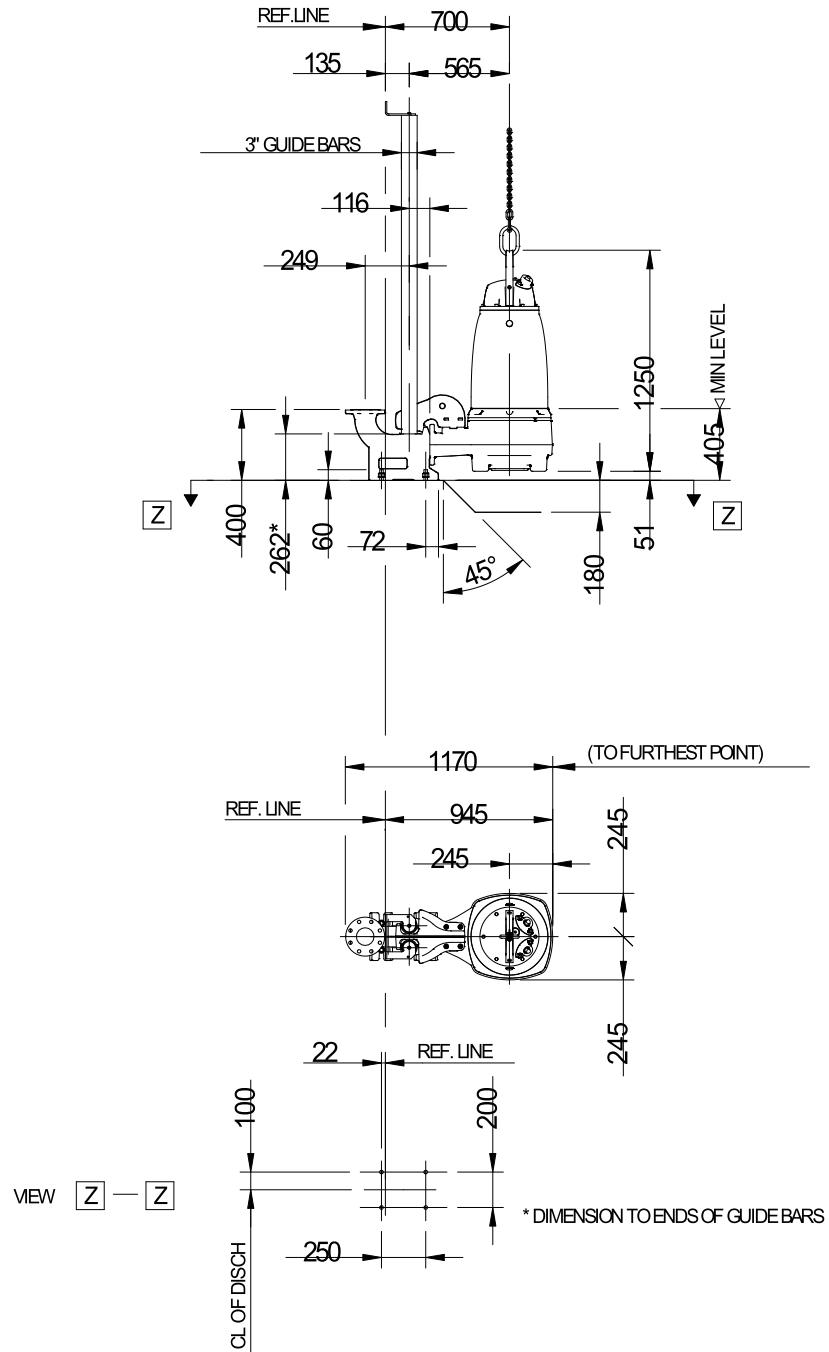

FP,NP 3202,095, 185, 350, 390 SH

FPNP 3202,095,185,350,390 SH

Project omschrijving	Projectnummer	Aangemaakt door:	Aangemaakt op 9/27/2018	Laatste wijziging
----------------------	---------------	------------------	----------------------------	-------------------