

## NP 3202 SH 3~ 274

### Technische specificaties

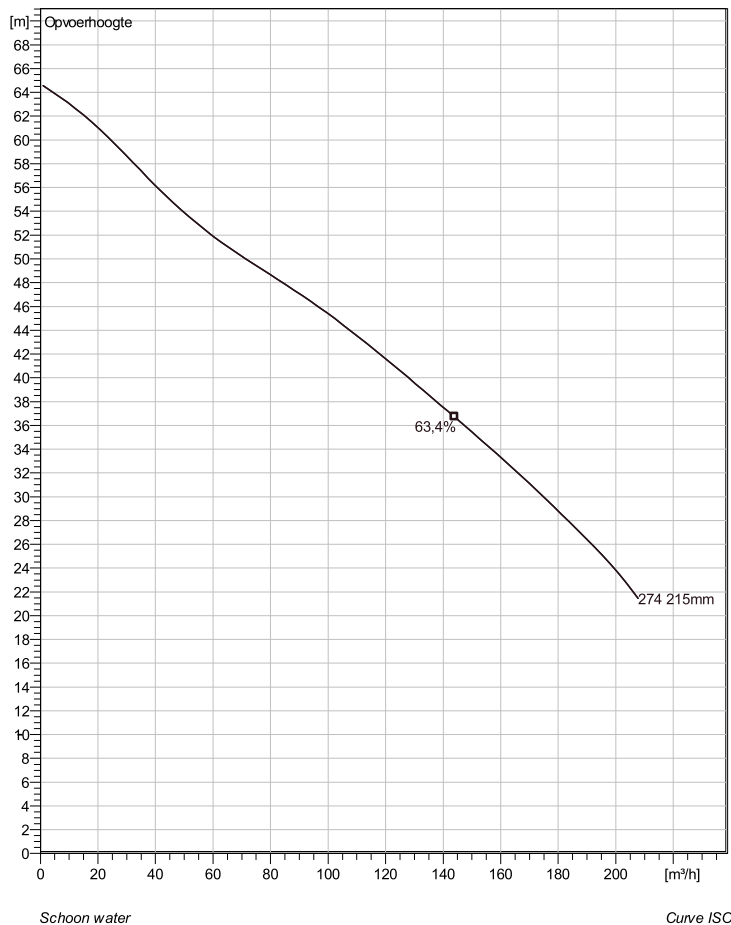

Note: Picture might not correspond to the current configuration.

#### General

Dompelbare pompen voorzien van een verstopingsongevoeilige N-waaiër. Geschikt voor afvalwater met grotere delen zoals rioolwater, regenwater en industriële afvalwater. Materiaal gietijzer.

#### Impeller

Impeller material	Hard-Iron
Persaansluiting	100 mm
Diameter aanzuigzijde	150 mm
Impeller diameter	215 mm
Aantal bladen	2

#### Motor

Motor #	N3202.185 30-19-2AA-W 32KW standaard
Stator variant	38
Frequentie	50 Hz
Nominale spanning	380 V
Aantal polen	2
Fasen	3~
Nominaal vermogen	32 kW
Toegekende stroom	58 A
Aanloopstroom	405 A
Nominaal toerental	2950 rpm
Vermogensfactor	
1/1 Load	0,93
3/4 Load	0,92
1/2 Load	0,88
Motor efficiency	
1/1 Load	90,1 %
3/4 Load	90,6 %
1/2 Load	90,0 %

#### Soort installatie: Semi Permanent, Nat

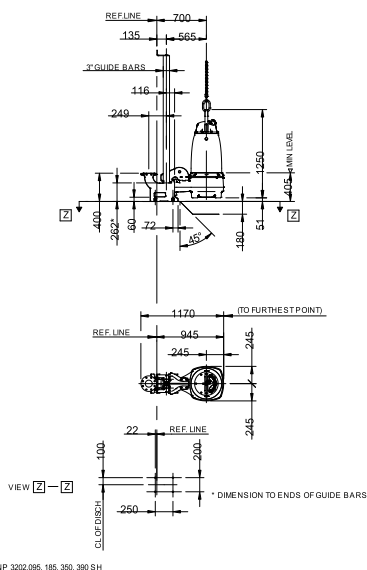

Project omschrijving	Projectnummer	Aangemaakt door:	Aangemaakt op 9/27/2018	Laatste wijziging
----------------------	---------------	------------------	----------------------------	-------------------

## NP 3202 SH 3~ 274

### Karakteristiek

#### Pomp

Persaansluiting	100 mm
Diameter aanzuigzijde	150 mm
Impeller diameter	215 mm
Aantal bladen	2

#### Motor

Motor #	N3202.185 30-19-2AA-W 32KW
Stator variant	38
Frequentie	50 Hz
Nominale spanning	380 V
Aantal polen	2
Fasen	3~
Nominaal vermogen	32 kW
Toegekende stroom	58 A
Aanloopstroom	405 A
Nominaal toerental	2950 rpm

Vermogensfactor	
1/1 Load	0,93
3/4 Load	0,92
1/2 Load	0,88
Motor efficiency	
1/1 Load	90,1 %
3/4 Load	90,6 %
1/2 Load	90,0 %

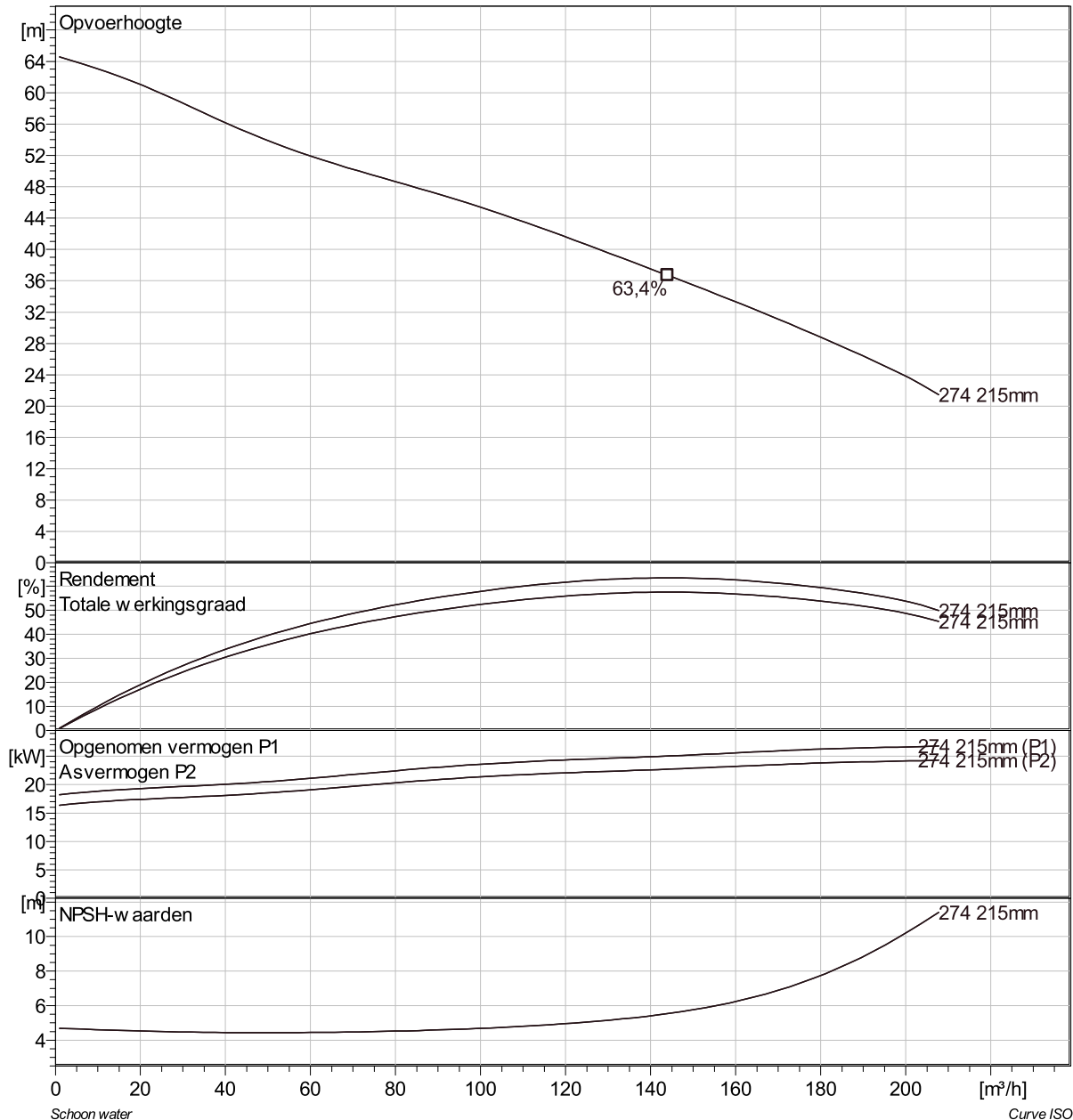

Project omschrijving	Projectnummer	Aangemaakt door:	Aangemaakt op 9/27/2018	Laatste wijziging
----------------------	---------------	------------------	----------------------------	-------------------

## NP 3202 SH 3~ 274 VFD Analysis

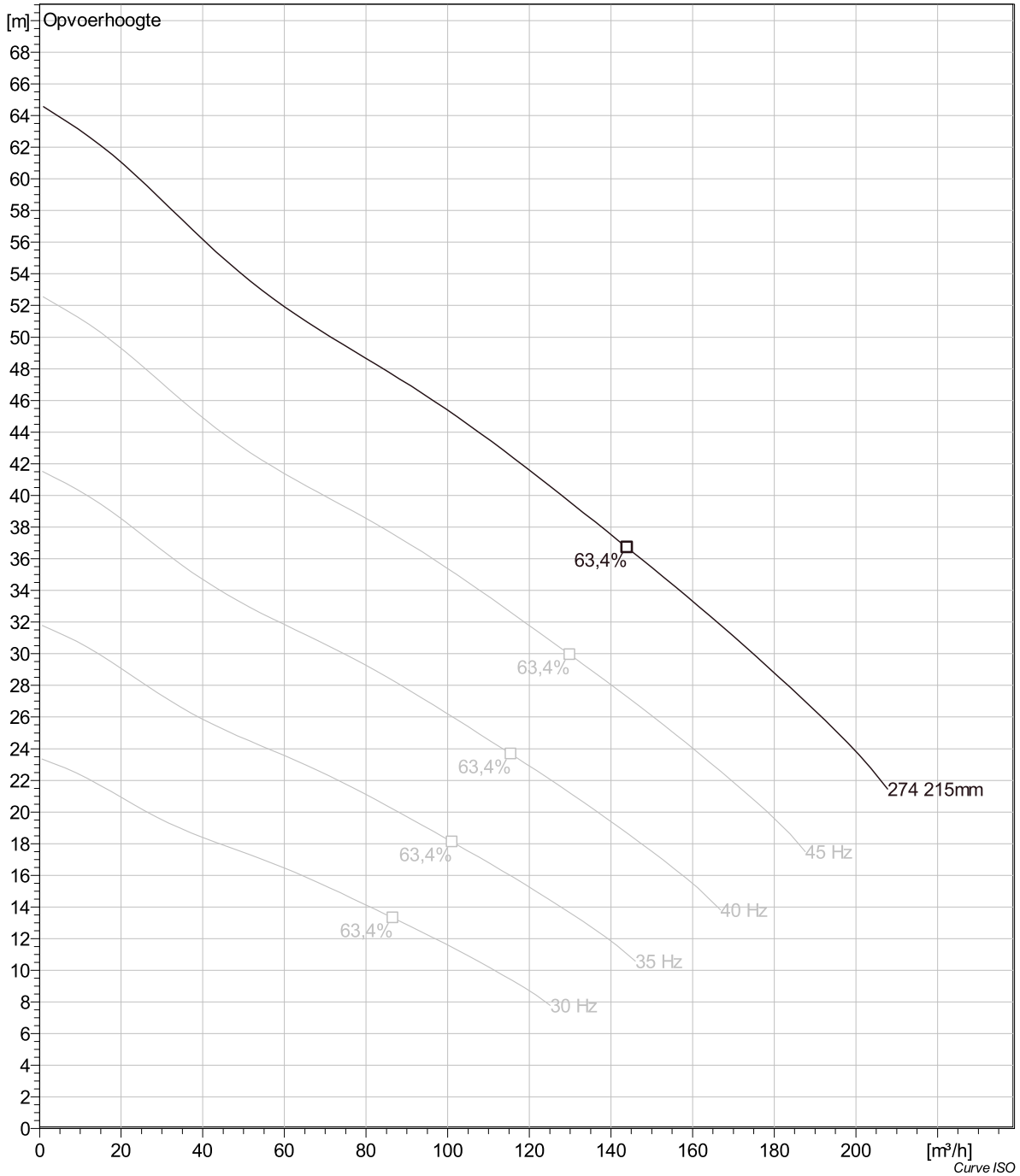

Project omschrijving	Projectnummer	Aangemaakt door:	Aangemaakt op 9/27/2018	Laatste wijziging
----------------------	---------------	------------------	----------------------------	-------------------

## NP 3202 SH 3~ 274 Dimensional drawing

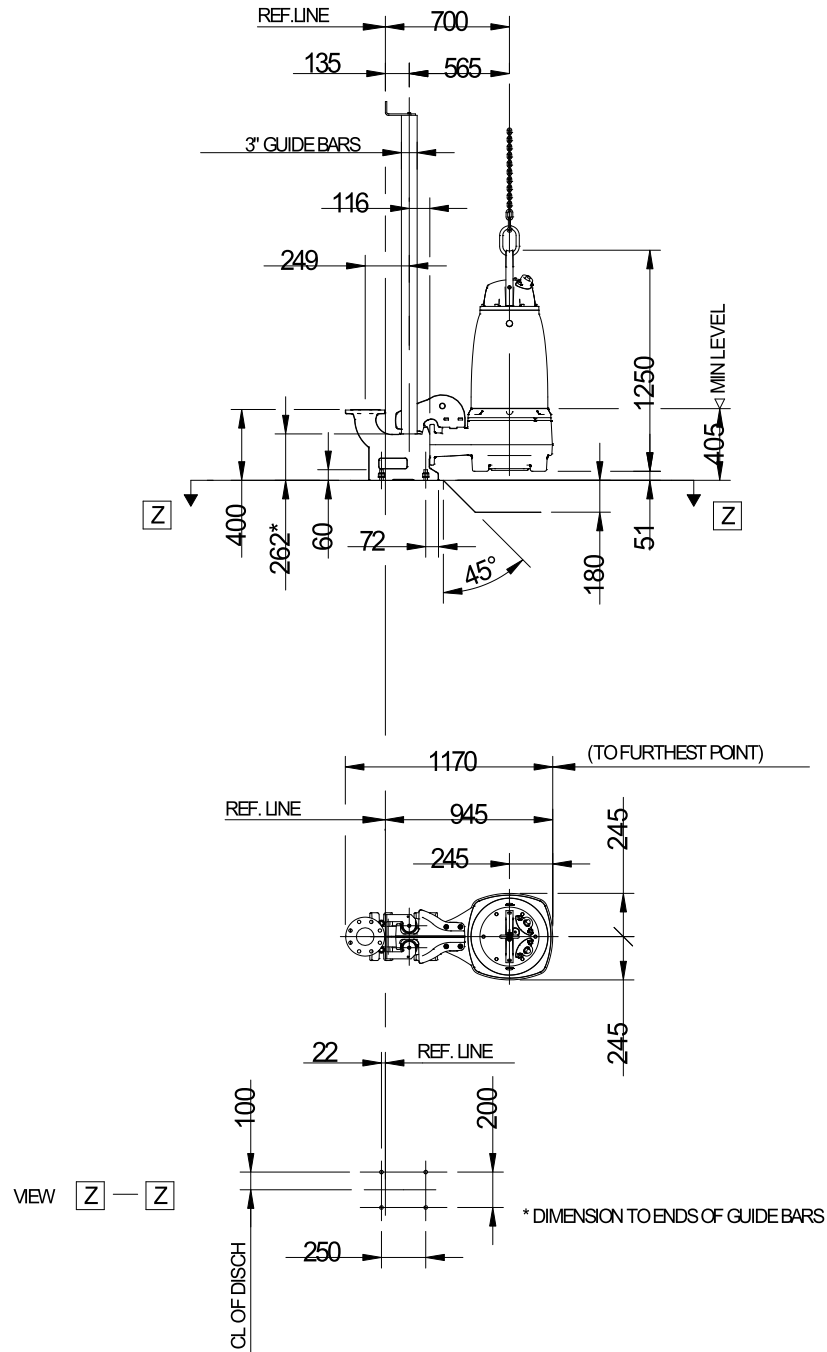

FP,NP 3202,095, 185, 350, 390 SH

FPNP 3202,095,185,350,390 SH

Project omschrijving	Projectnummer	Aangemaakt door:	Aangemaakt op 9/27/2018	Laatste wijziging
----------------------	---------------	------------------	----------------------------	-------------------