



## NS 3202 LT 3~ 615

### Karakteristiek

#### Pomp

Persaansluiting	300 mm
Diameter aanzuigzijde	300 mm
Impeller diameter	342 mm
Aantal bladen	2
Throughlet diameter	92 mm

#### Motor

Motor #	N3202.180 30-18-6AA-W 22KW
Stator variant	1
Frequentie	50 Hz
Nominale spanning	380 V
Aantal polen	6
Fasen	3~
Nominaal vermogen	22 kW
Toegekende stroom	44 A
Aanloopstroom	225 A
Nominaal toerental	970 rpm

Vermogensfactor	
1/1 Load	0,87
3/4 Load	0,84
1/2 Load	0,76
Motor efficiency	
1/1 Load	88,0 %
3/4 Load	89,5 %
1/2 Load	89,5 %

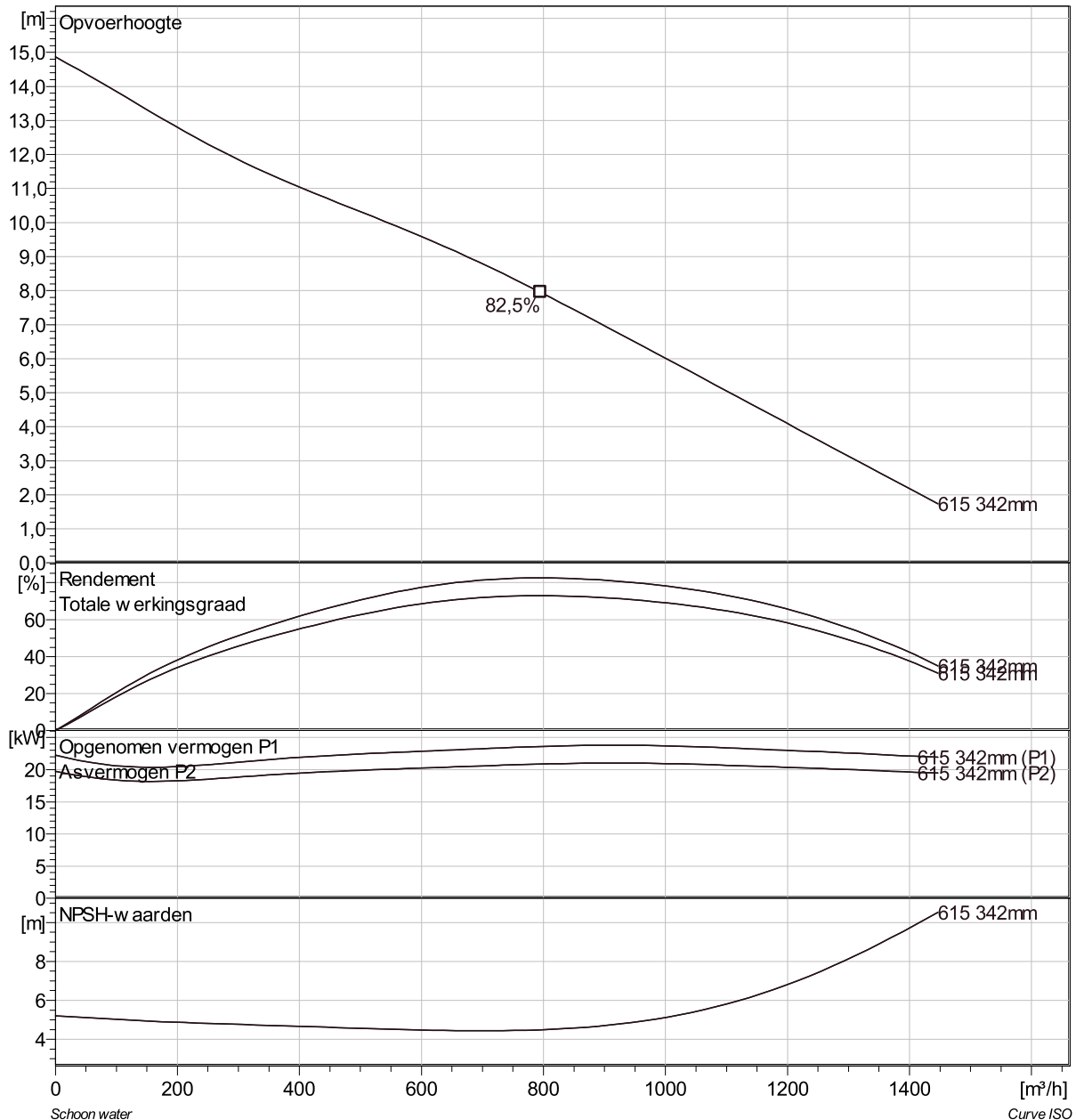

Project	Project ID	Created by	Created on 10/5/2018	Last update
---------	------------	------------	-------------------------	-------------

## NS 3202 LT 3~ 615 VFD Analysis

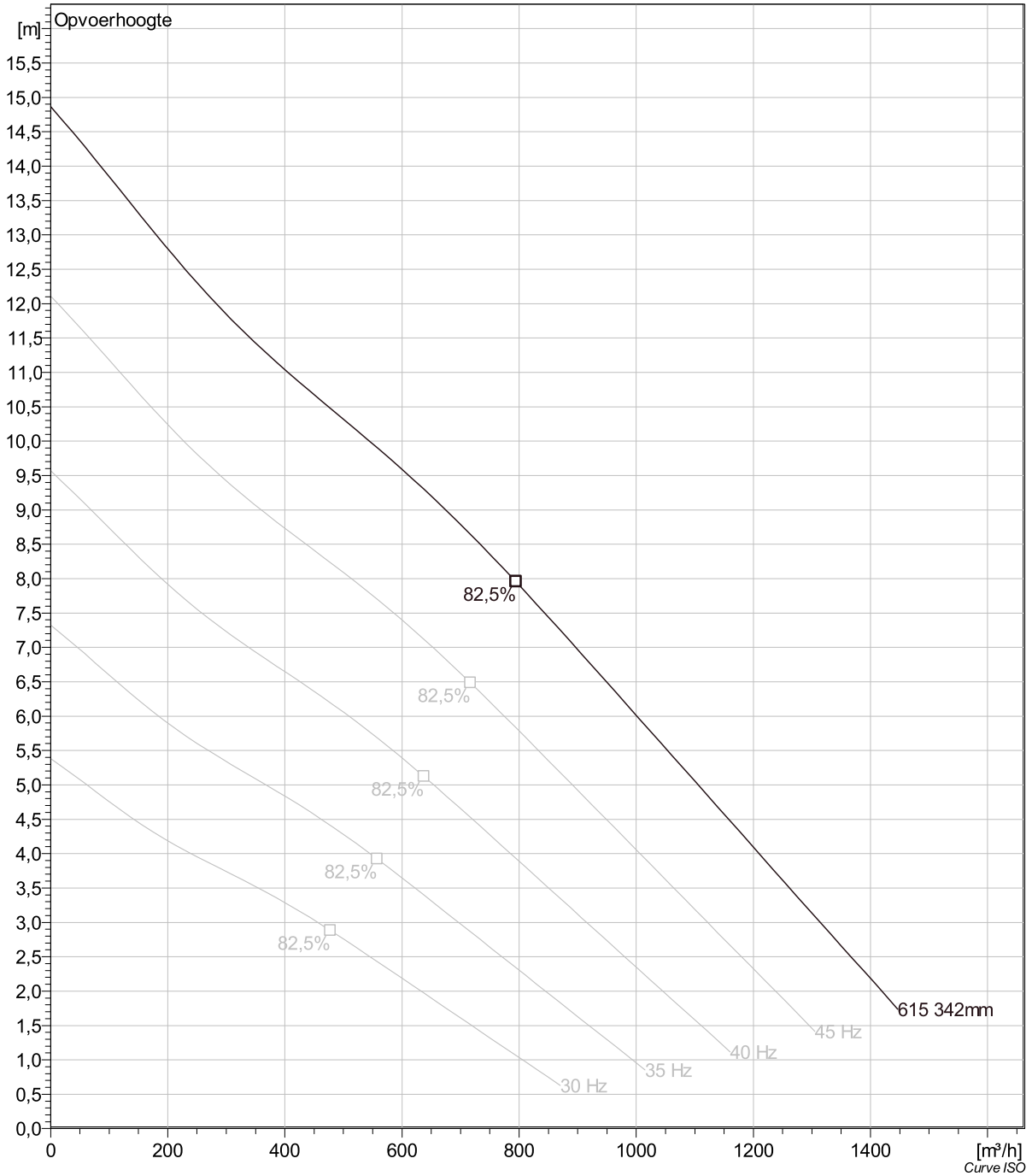

Project	Project ID	Created by	Created on	Last update
			10/5/2018	

## NS 3202 LT 3~ 615 Dimensional drawing

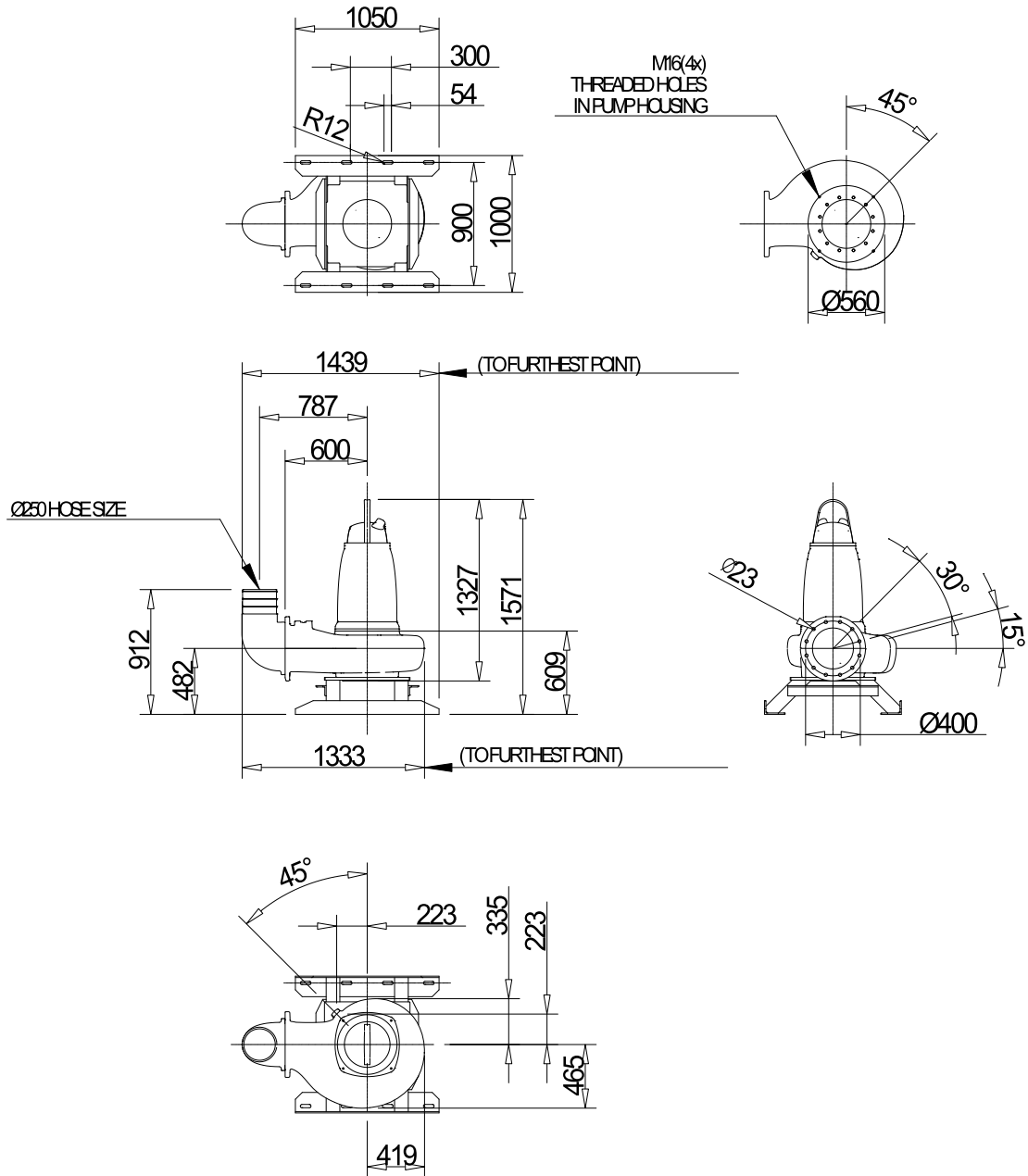

NS 3202,080,095,180,185,350,390,660,670 LT

Weight (kg)
Total incl. stand
900

Dimensional dwg

NS 3202,090,095,180,185,350,390,660,670 LT

Project	Project ID	Created by	Created on 10/5/2018	Last update
---------	------------	------------	-------------------------	-------------