

NP 3301 LT 3~ 626 Technische specificaties

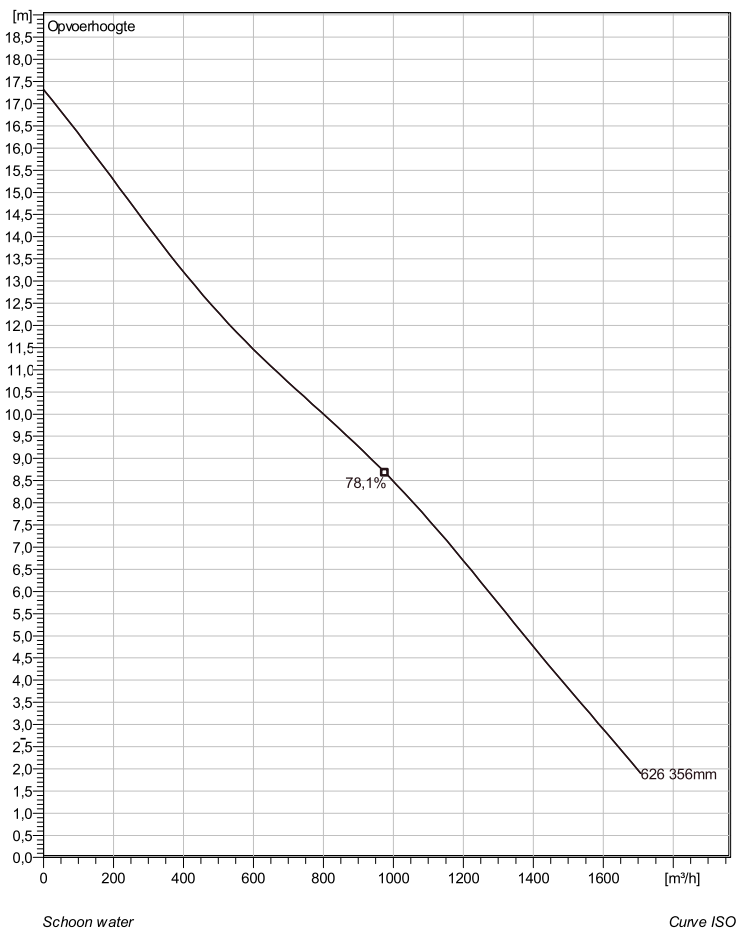

Note: Picture might not correspond to the current configuration.

General

Dompelbare pompen voorzien van verstopingsongevoeilige N-waaiers. Geschikt voor afvalwater met grotere delen zoals rioolwater, regenwater en industriële afvalwater. Materiaal gietijzer.

Impeller

Impeller material	Grey cast iron
Persaansluiting	300 mm
Diameter aanzuigzijde	300 mm
Impeller diameter	356 mm
Aantal bladen	2

Motor

Motor #	N3301.180 35-25-6AA-W 45KW standaard
Stator variant	1
Frequentie	50 Hz
Nominale spanning	380 V
Aantal polen	6
Fasen	3~
Nominaal vermogen	45 kW
Toegekende stroom	93 A
Aanloopstroom	510 A
Nominaal toerental	985 rpm
Vermogensfactor	
1/1 Load	0,81
3/4 Load	0,77
1/2 Load	0,67
Motor efficiency	
1/1 Load	90,0 %
3/4 Load	91,0 %
1/2 Load	91,5 %

Soort installatie: Semi Permanent, Nat

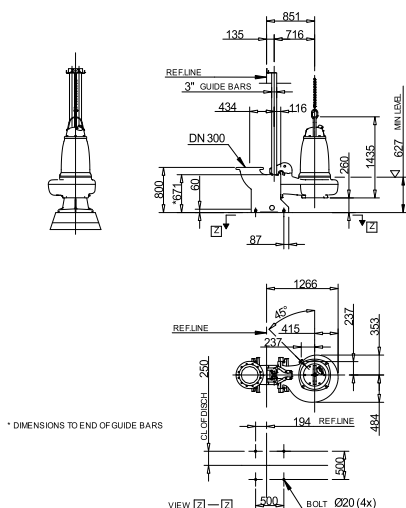

6 poles
NP 3301.090, 095, 180, 185, 660, 670 LT

Dimensional dwg
NP 3301.090, 095, 180, 185, 660, 670 LT

Project omschrijving	Projectnummer	Aangemaakt door:	Aangemaakt op 9/27/2018	Laatste wijziging
----------------------	---------------	------------------	----------------------------	-------------------

NP 3301 LT 3~ 626

Karakteristiek

Pomp

Persaansluiting	300 mm
Diameter aanzuigzijde	300 mm
Impeller diameter	356 mm
Aantal bladen	2

Motor

Motor #	N3301.180 35-25-6AA-W 45KW
Stator variant	1
Frequentie	50 Hz
Nominale spanning	380 V
Aantal polen	6
Fasen	3~
Nominaal vermogen	45 kW
Toegekende stroom	93 A
Aanloopstroom	510 A
Nominaal toerental	985 rpm

Vermogensfactor	
1/1 Load	0,81
3/4 Load	0,77
1/2 Load	0,67
Motor efficiency	
1/1 Load	90,0 %
3/4 Load	91,0 %
1/2 Load	91,5 %

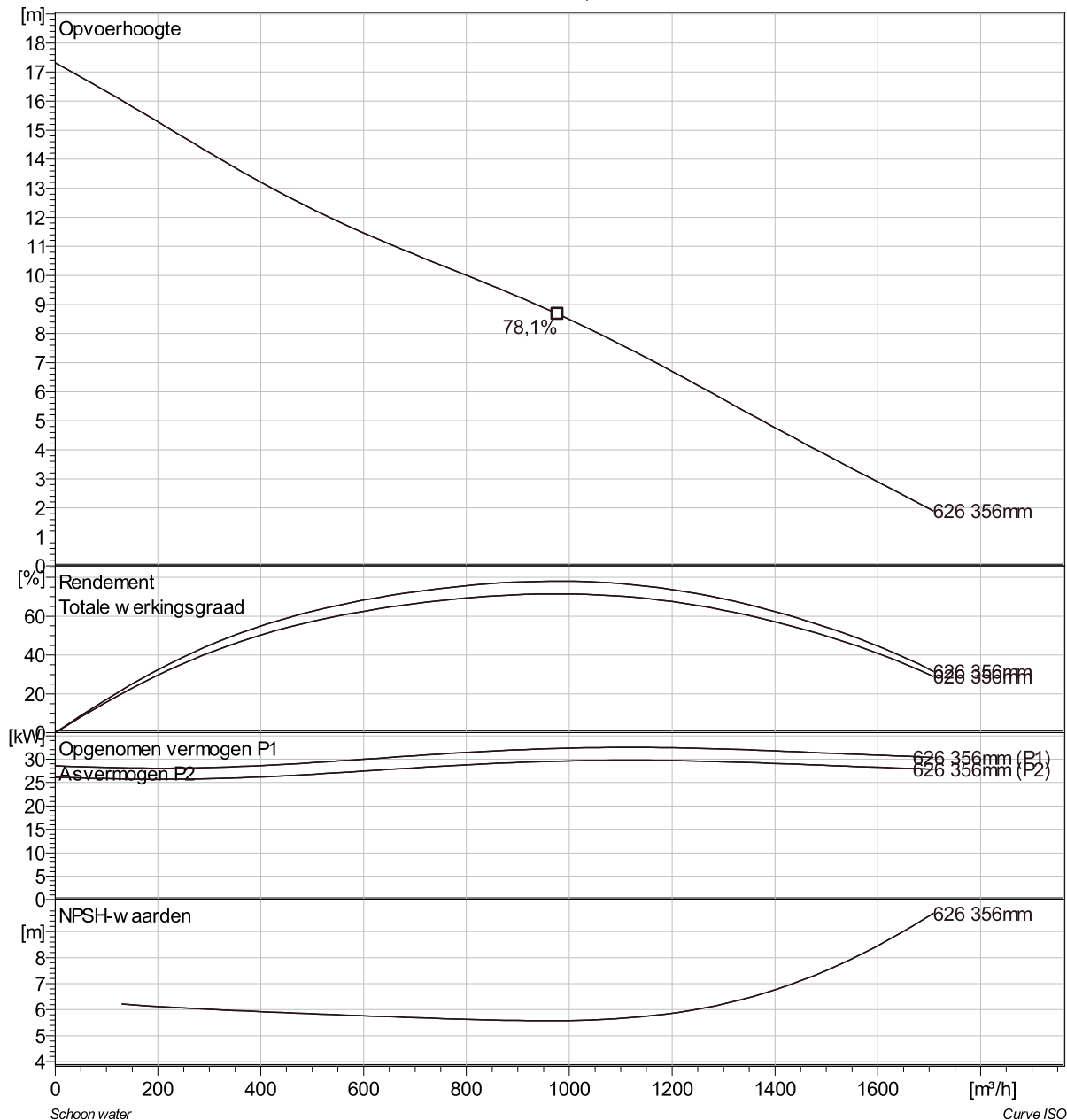

Project omschrijving	Projectnummer	Aangemaakt door:	Aangemaakt op 9/27/2018	Laatste wijziging
----------------------	---------------	------------------	----------------------------	-------------------

NP 3301 LT 3~ 626



VFD Analysis

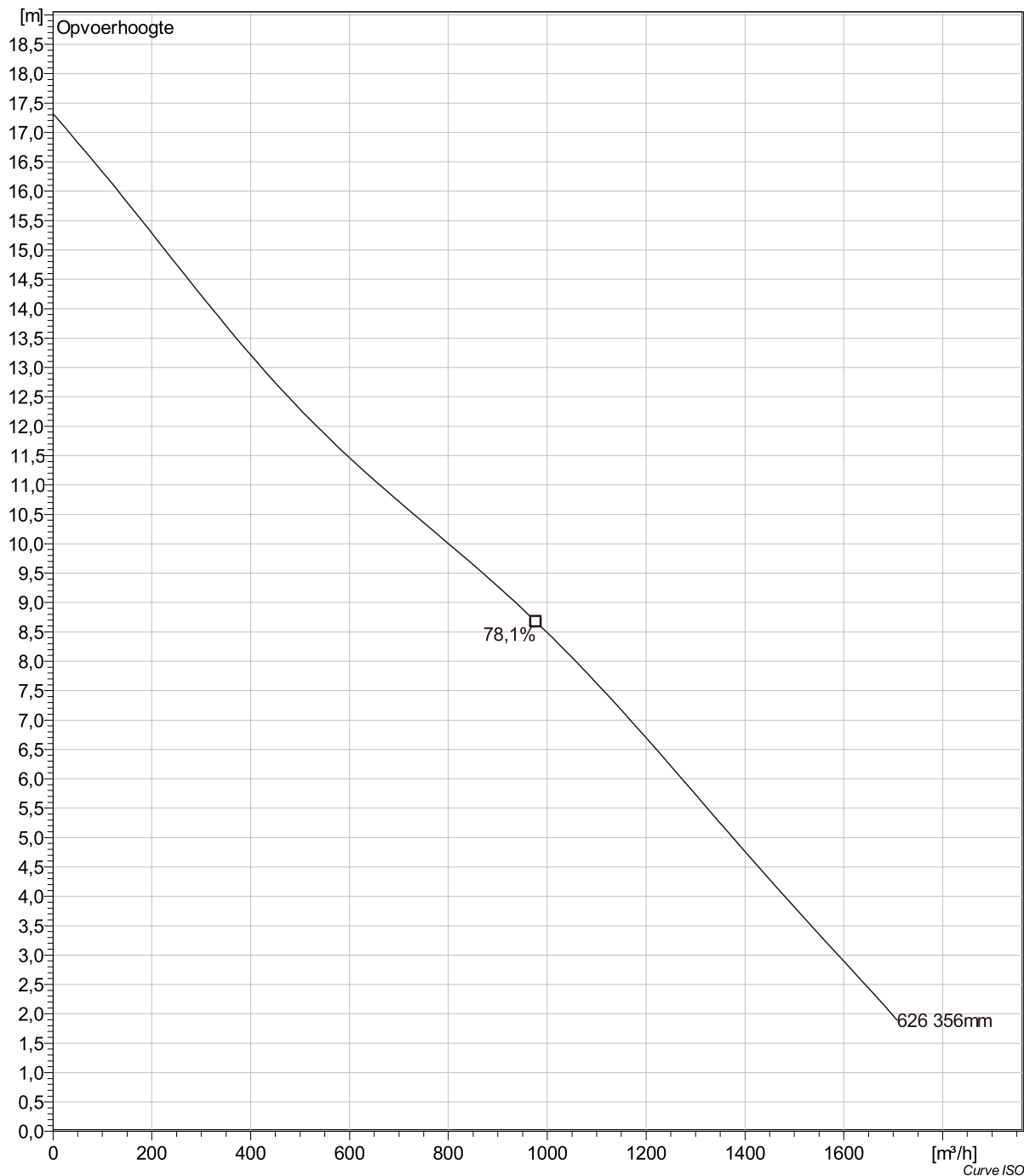

Project omschrijving	Projectnummer	Aangemaakt door:	Aangemaakt op 9/27/2018	Laatste wijziging
----------------------	---------------	------------------	----------------------------	-------------------

NP 3301 LT 3~ 626 Dimensional drawing

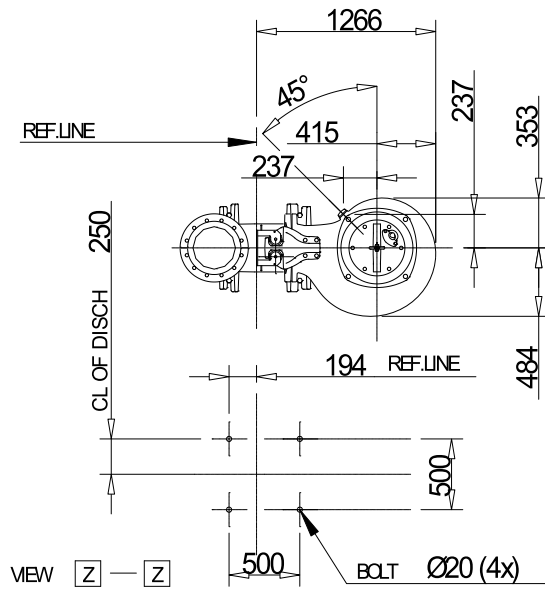
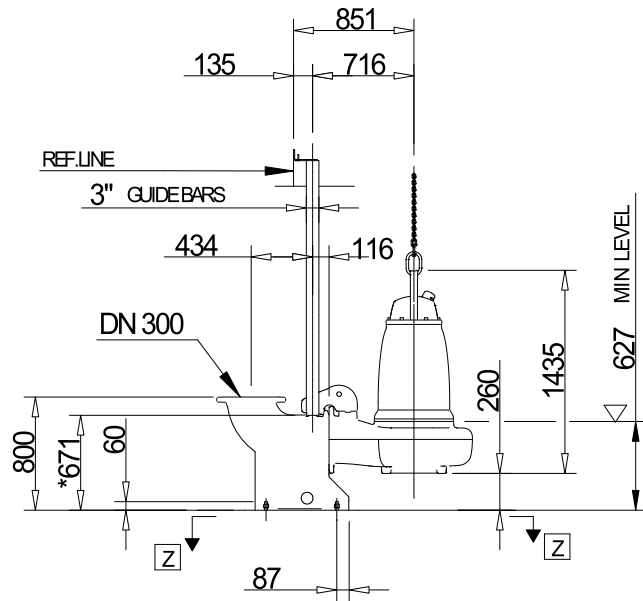
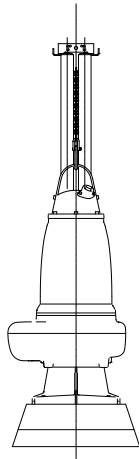

* DIMENSIONS TO END OF GUIDE BARS

6-poles
NP 3301.090, 095, 180, 185, 660, 670 LT

Dimensional drwg
NP 3301.090, 095, 180, 185, 660, 670 LT

Project omschrijving	Projectnummer	Aangemaakt door:	Aangemaakt op 9/27/2018	Laatste wijziging
----------------------	---------------	------------------	----------------------------	-------------------