

NS 3301 LT 3~ 624 Technische specificaties

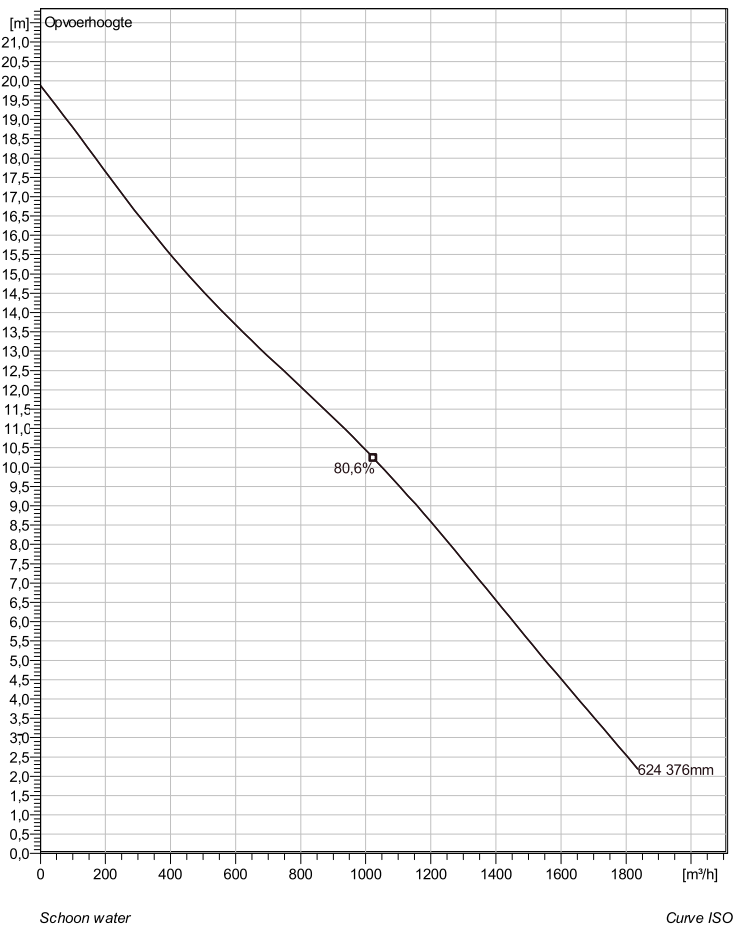

Note: Picture might not correspond to the current configuration.

General

Dompelbare pompen voorzien van een verstopingsongevoeilige N-waaiër. Geschikt voor afvalwater met grotere delen zoals rioolwater, regenwater en industriële afvalwater. Materiaal gietijzer.

Impeller

| | |
|-----------------------|----------------|
| Impeller material | Grey cast iron |
| Persaansluiting | 300 mm |
| Diameter aanzuigzijde | 300 mm |
| Impeller diameter | 376 mm |
| Aantal bladen | 2 |

Motor

| | |
|--------------------|--------------------------------------|
| Motor # | N3301.180 35-25-6AA-W 45KW standaard |
| Stator variant | 1 |
| Frequentie | 50 Hz |
| Nominale spanning | 380 V |
| Aantal polen | 6 |
| Fasen | 3~ |
| Nominaal vermogen | 45 kW |
| Toegekende stroom | 93 A |
| Aanloopstroom | 510 A |
| Nominaal toerental | 985 rpm |
| Vermogensfactor | |
| 1/1 Load | 0,81 |
| 3/4 Load | 0,77 |
| 1/2 Load | 0,67 |
| Motor efficiency | |
| 1/1 Load | 90,0 % |
| 3/4 Load | 91,0 % |
| 1/2 Load | 91,5 % |

Soort installatie: Semi permanent, Nat

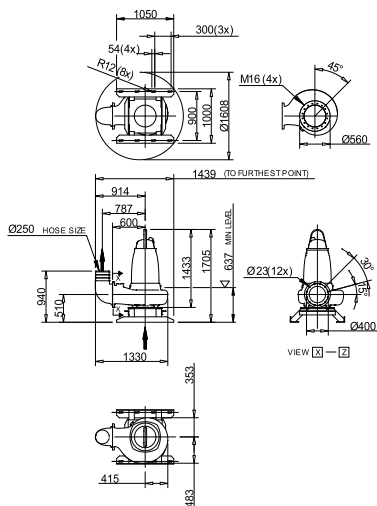

6pages
NS 3301.090,095,180,185,660,670 LT

Dimensional dwg
NS 3301.090,095,180,185,660,670 LT

| | | | | |
|---------|------------|------------|-------------------------|-------------|
| Project | Project ID | Created by | Created on 10/5/2018 | Last update |
|---------|------------|------------|-------------------------|-------------|

NS 3301 LT 3~ 624



Karakteristiek

Pomp

| | |
|-----------------------|--------|
| Persaansluiting | 300 mm |
| Diameter aanzuigzijde | 300 mm |
| Impeller diameter | 376 mm |
| Aantal bladen | 2 |

Motor

| | |
|--------------------|----------------------------|
| Motor # | N3301.180 35-25-6AA-W 45KW |
| Stator variant | 1 |
| Frequentie | 50 Hz |
| Nominale spanning | 380 V |
| Aantal polen | 6 |
| Fasen | 3~ |
| Nominaal vermogen | 45 kW |
| Toegekende stroom | 93 A |
| Aanloopstroom | 510 A |
| Nominaal toerental | 985 rpm |

| | |
|------------------|--------|
| Vermogensfactor | |
| 1/1 Load | 0,81 |
| 3/4 Load | 0,77 |
| 1/2 Load | 0,67 |
| Motor efficiency | |
| 1/1 Load | 90,0 % |
| 3/4 Load | 91,0 % |
| 1/2 Load | 91,5 % |

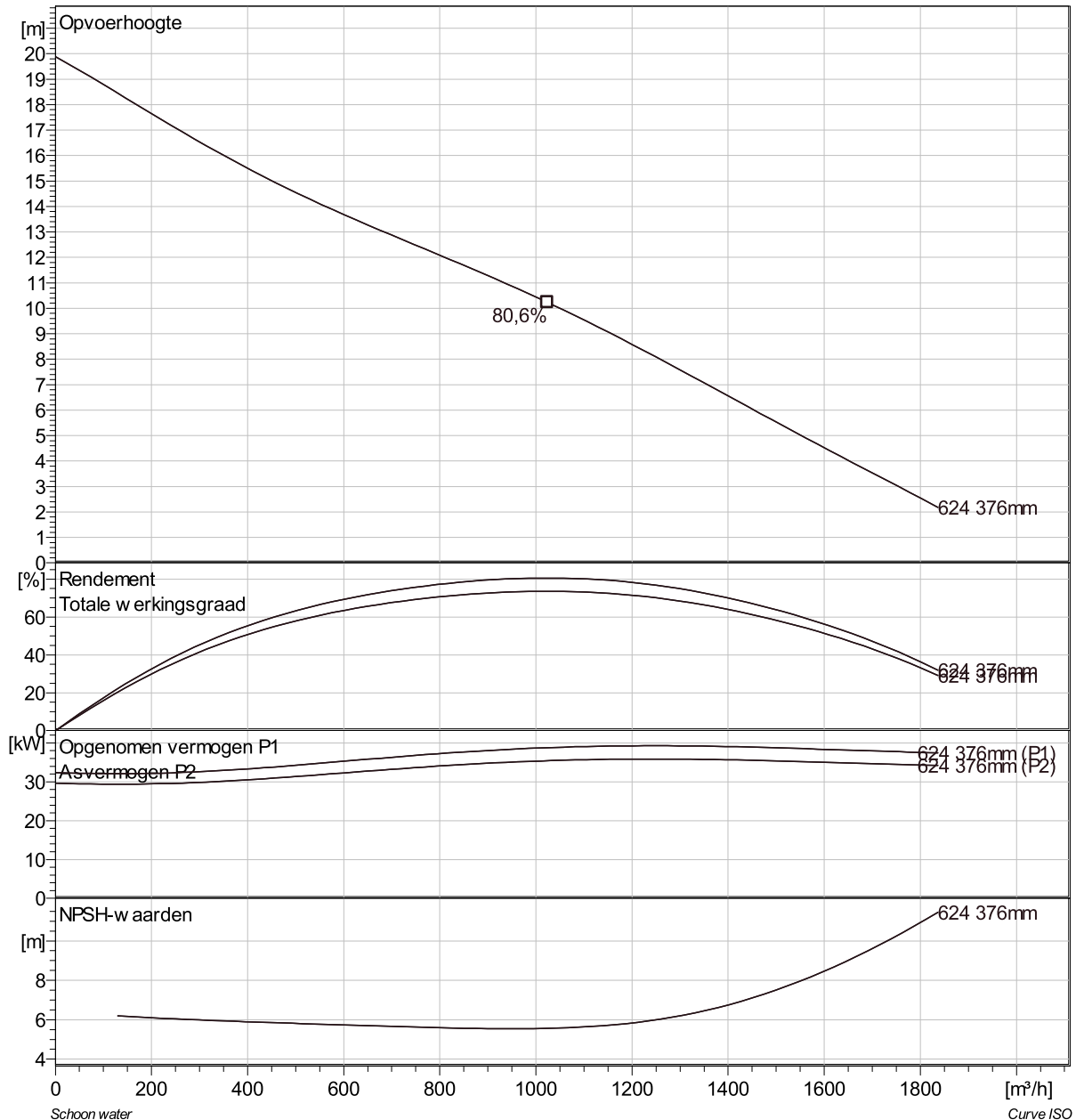

| | | | | |
|---------|------------|------------|-------------------------|-------------|
| Project | Project ID | Created by | Created on 10/5/2018 | Last update |
|---------|------------|------------|-------------------------|-------------|

NS 3301 LT 3~ 624 VFD Analysis

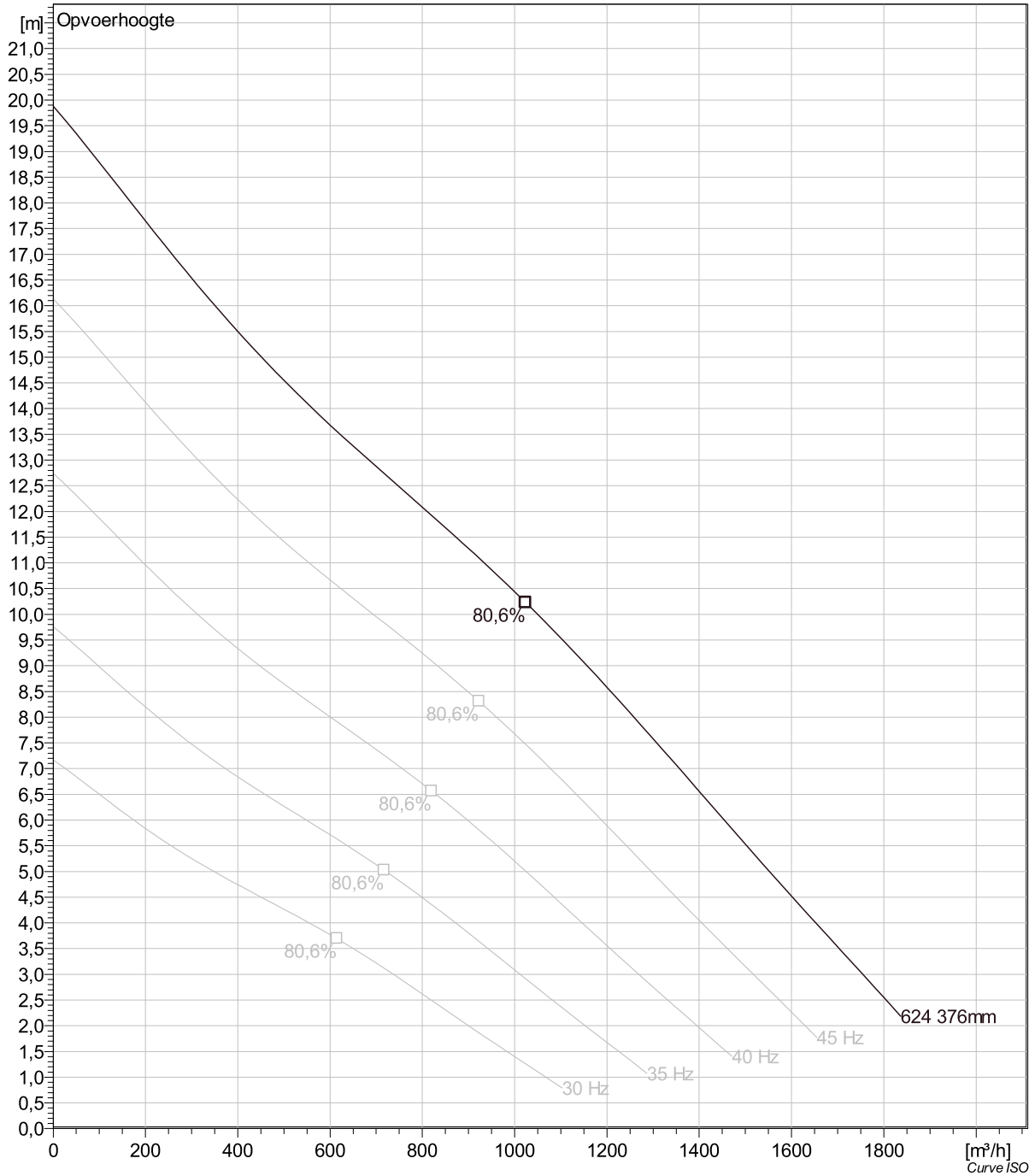

| Project | Project ID | Created by | Created on | Last update |
|---------|------------|------------|------------|-------------|
| | | | 10/5/2018 | |

NS 3301 LT 3~ 624 Dimensional drawing

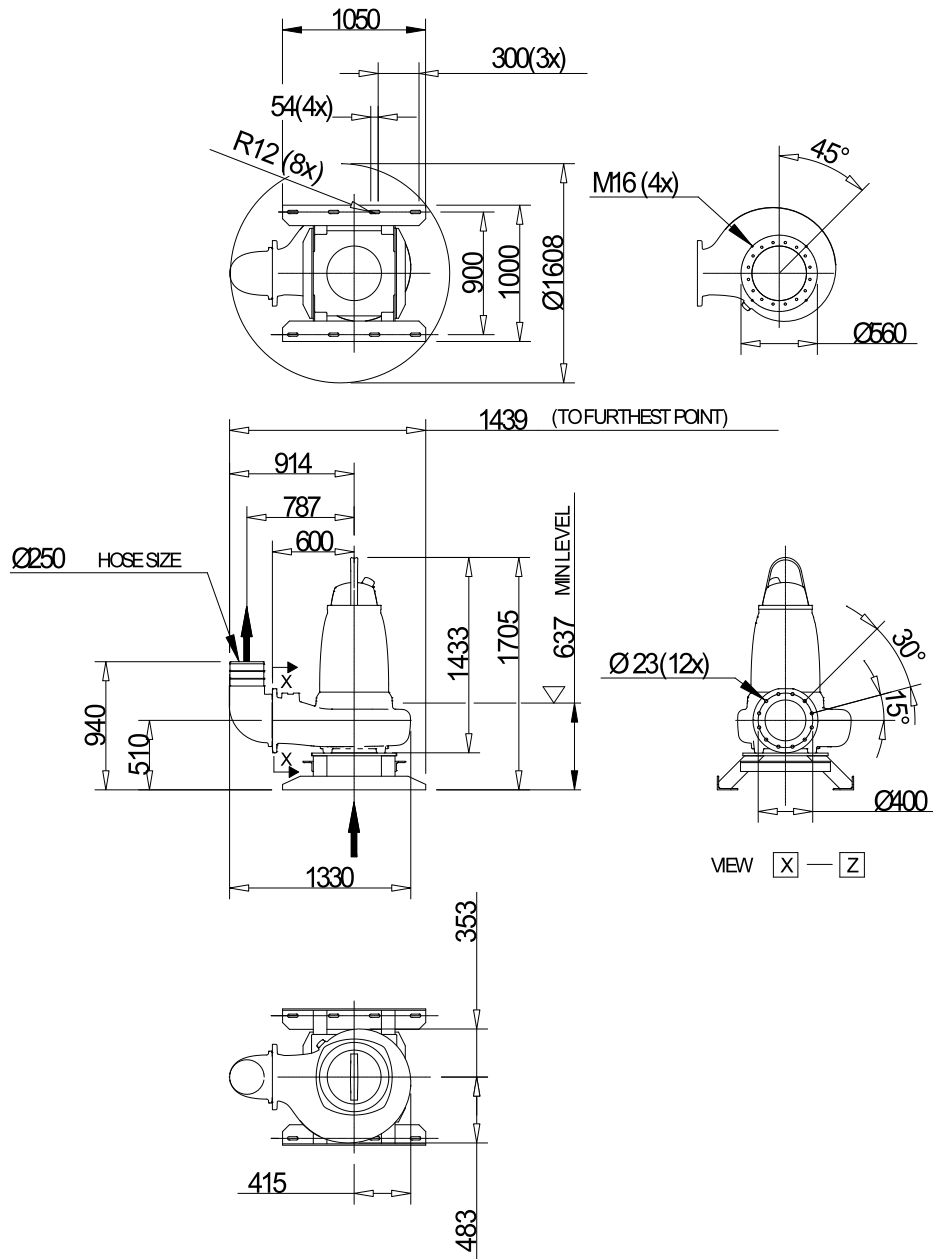

6-poles

NS 3301.090, 095, 180, 185, 660, 670 LT

Denomination

Dimensional dwg

NS 3301.090,095, 180, 185,660,670 LT

| Project | Project ID | Created by | Created on | Last update |
|---------|------------|------------|------------|-------------|
| | | | 10/5/2018 | |