

NP 3315 HT 3~ 451

Technische specificaties

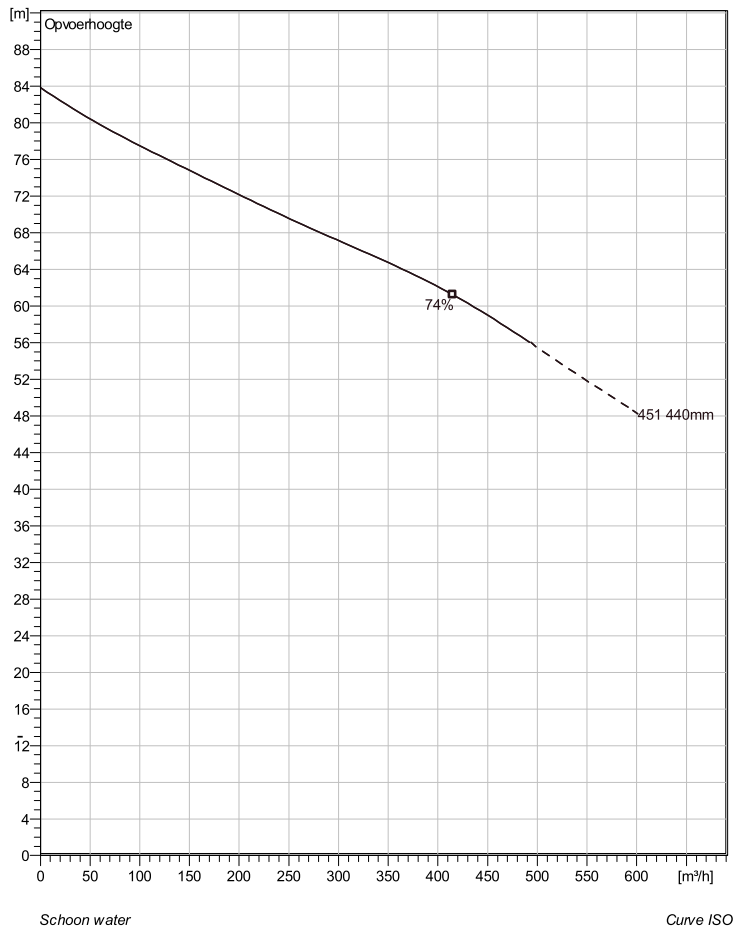

Note: Picture might not correspond to the current configuration.

General

Dompelbare pompen voorzien van verstopingsongevoeilige N-waaiers. Geschikt voor afvalwater met grotere delen zoals rioolwater, regenwater en industriële afvalwater. Materiaal gietijzer.

Impeller

Impeller material	Grey cast iron
Persaansluiting	150 mm
Diameter aanzuigzijde	150 mm
Impeller diameter	440 mm
Aantal bladen	3

Motor

Motor #	N3315.180 35-45-4AA-W 105KW standaard
Stator variant	1
Frequentie	50 Hz
Nominale spanning	400 V
Aantal polen	4
Fasen	3~
Nominaal vermogen	105 kW
Toegekende stroom	199 A
Aanloopstroom	1100 A
Nominaal toerental	1480 rpm
Vermogensfactor	
1/1 Load	0,81
3/4 Load	0,76
1/2 Load	0,64
Motor efficiency	
1/1 Load	93,9 %
3/4 Load	94,7 %
1/2 Load	94,9 %

Soort installatie: Semi Permanent, Nat

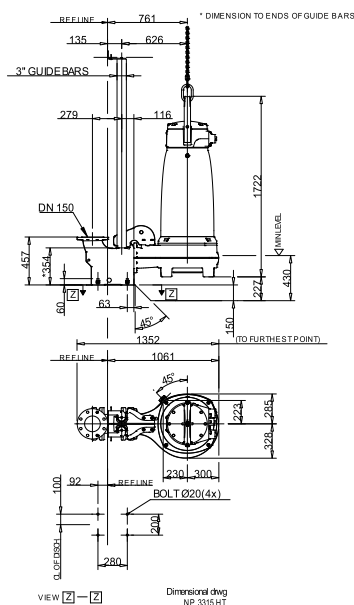

Project omschrijving	Projectnummer	Aangemaakt door:	Aangemaakt op 9/27/2018	Laatste wijziging
----------------------	---------------	------------------	----------------------------	-------------------

NP 3315 HT 3~ 451

Karakteristiek

Pomp

Persaansluiting	150 mm
Diameter aanzuigzijde	150 mm
Impeller diameter	440 mm
Aantal bladen	3

Motor

Motor #	N3315.180 35-45-4AA-W 105KW
Stator variant	1
Frequentie	50 Hz
Nominale spanning	400 V
Aantal polen	4
Fasen	3~
Nominaal vermogen	105 kW
Toegekende stroom	199 A
Aanloopstroom	1100 A
Nominaal toerental	1480 rpm

Vermogensfactor	
1/1 Load	0,81
3/4 Load	0,76
1/2 Load	0,64
Motor efficiency	
1/1 Load	93,9 %
3/4 Load	94,7 %
1/2 Load	94,9 %

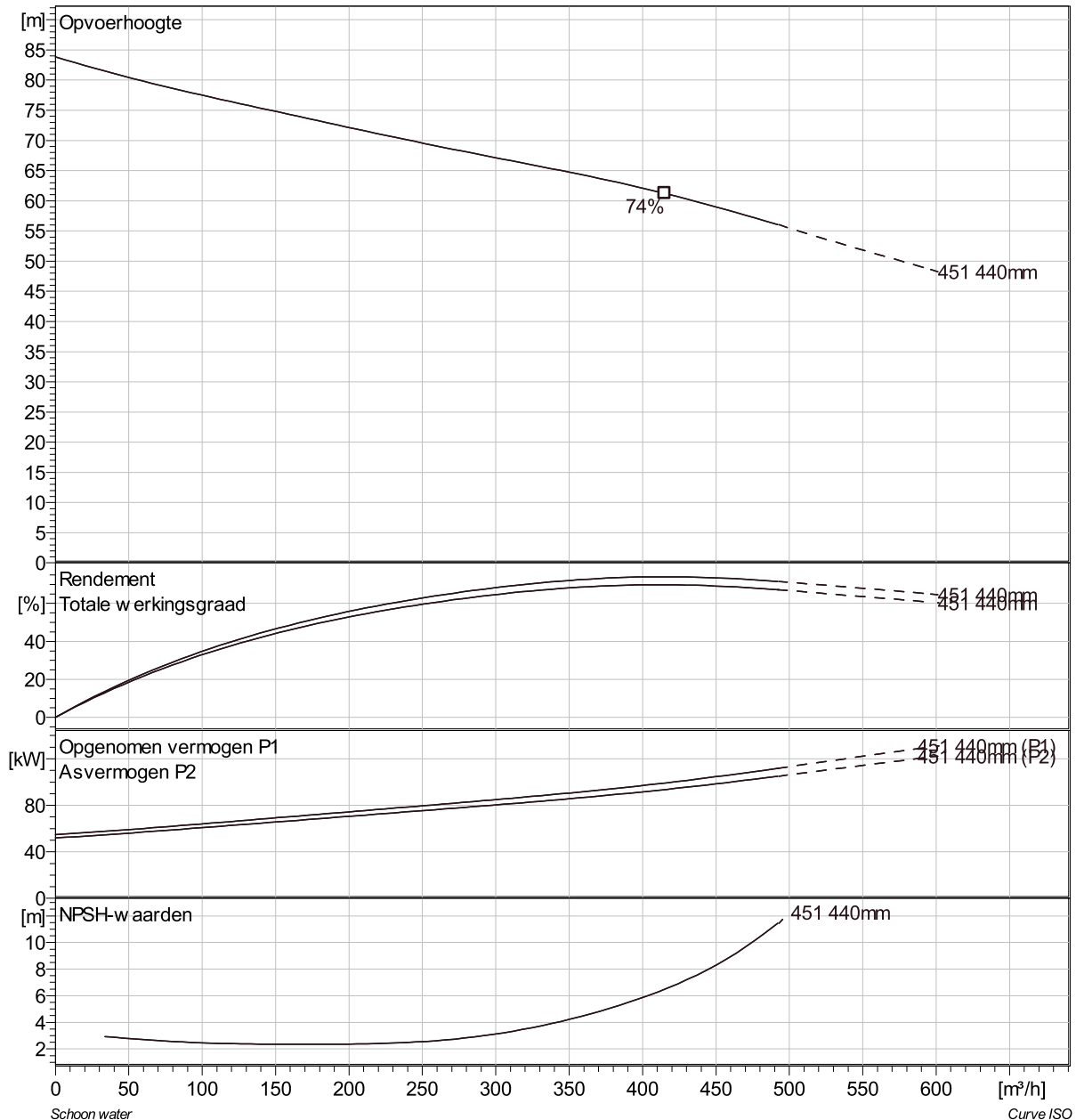

Project omschrijving	Projectnummer	Aangemaakt door:	Aangemaakt op 9/27/2018	Laatste wijziging
----------------------	---------------	------------------	----------------------------	-------------------

NP 3315 HT 3~ 451 VFD Analysis

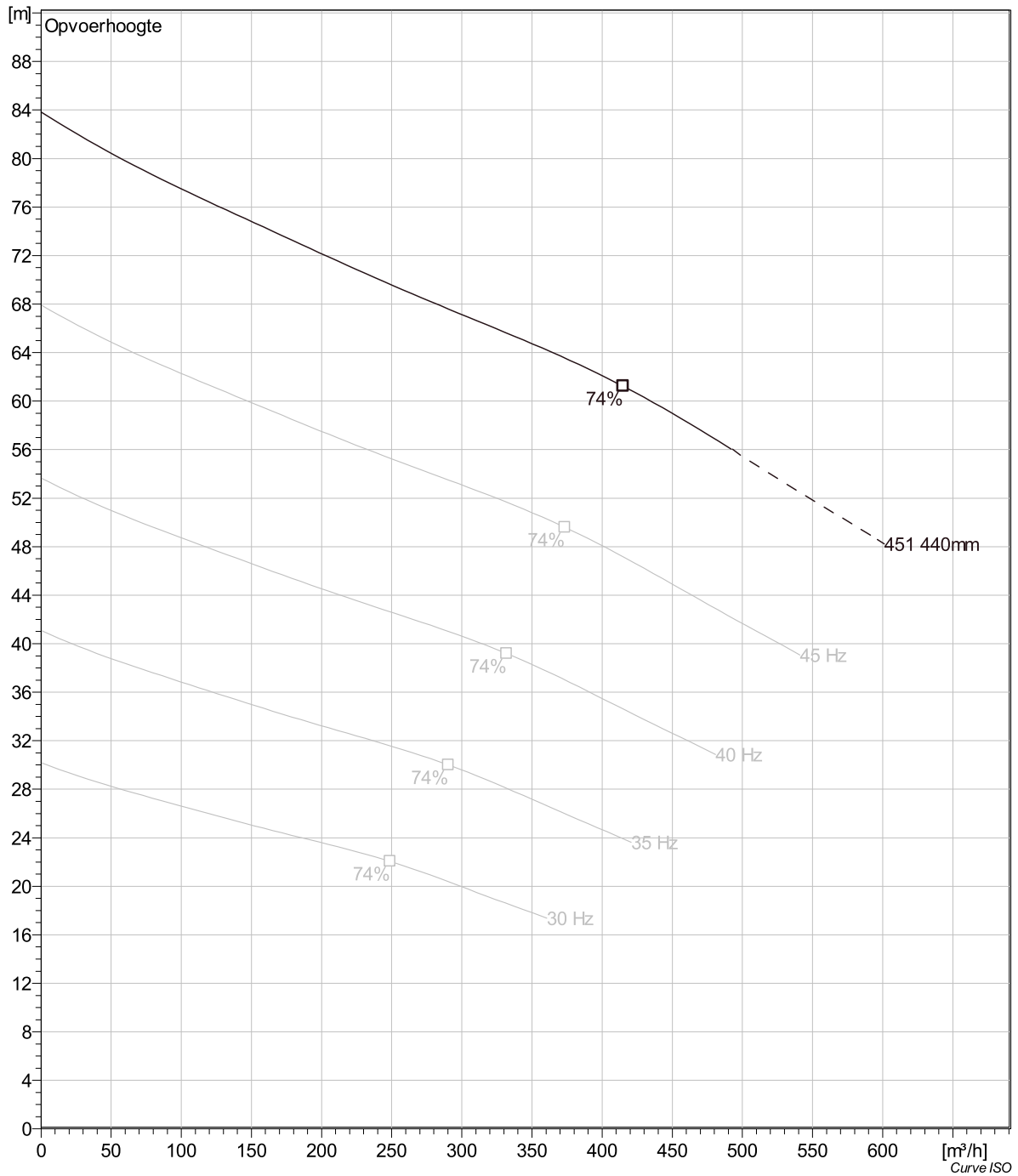

Project omschrijving	Projectnummer	Aangemaakt door:	Aangemaakt op 9/27/2018	Laatste wijziging
----------------------	---------------	------------------	----------------------------	-------------------

NP 3315 HT 3~ 451 Dimensional drawing

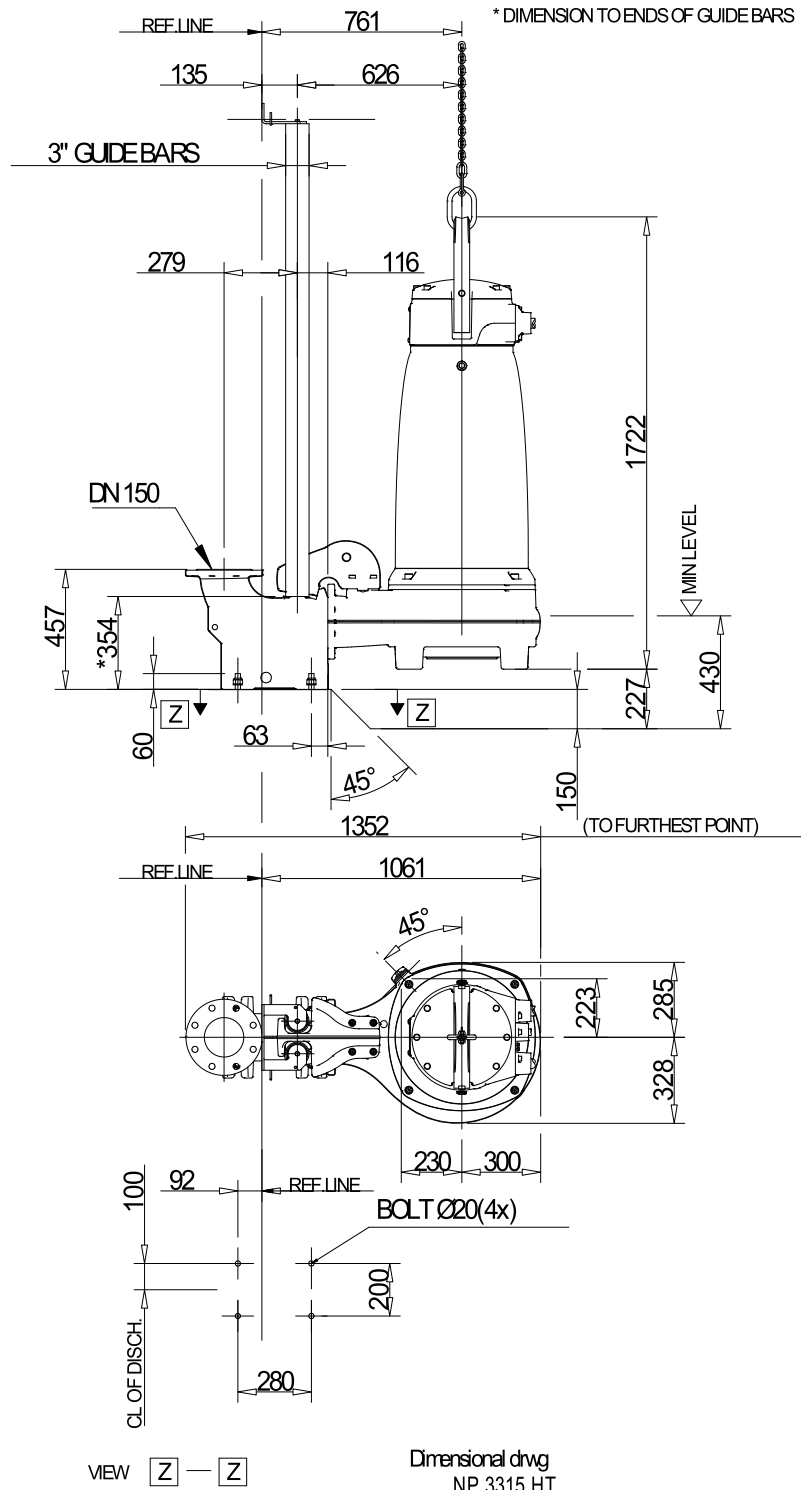

Project omschrijving	Projectnummer	Aangemaakt door:	Aangemaakt op 9/27/2018	Laatste wijziging
----------------------	---------------	------------------	----------------------------	-------------------