

NP 3315 HT 3~ 452

Karakteristiek

Pomp

Persaansluiting	150 mm
Diameter aanzuigzijde	150 mm
Impeller diameter	430 mm
Aantal bladen	3

Motor

Motor #	N3315.180 35-45-4AA-W 105KW
Stator variant	1
Frequentie	50 Hz
Nominale spanning	400 V
Aantal polen	4
Fasen	3~
Nominaal vermogen	105 kW
Toegekende stroom	199 A
Aanloopstroom	1100 A
Nominaal toerental	1480 rpm

Vermogensfactor	
1/1 Load	0,81
3/4 Load	0,76
1/2 Load	0,64
Motor efficiency	
1/1 Load	93,9 %
3/4 Load	94,7 %
1/2 Load	94,9 %

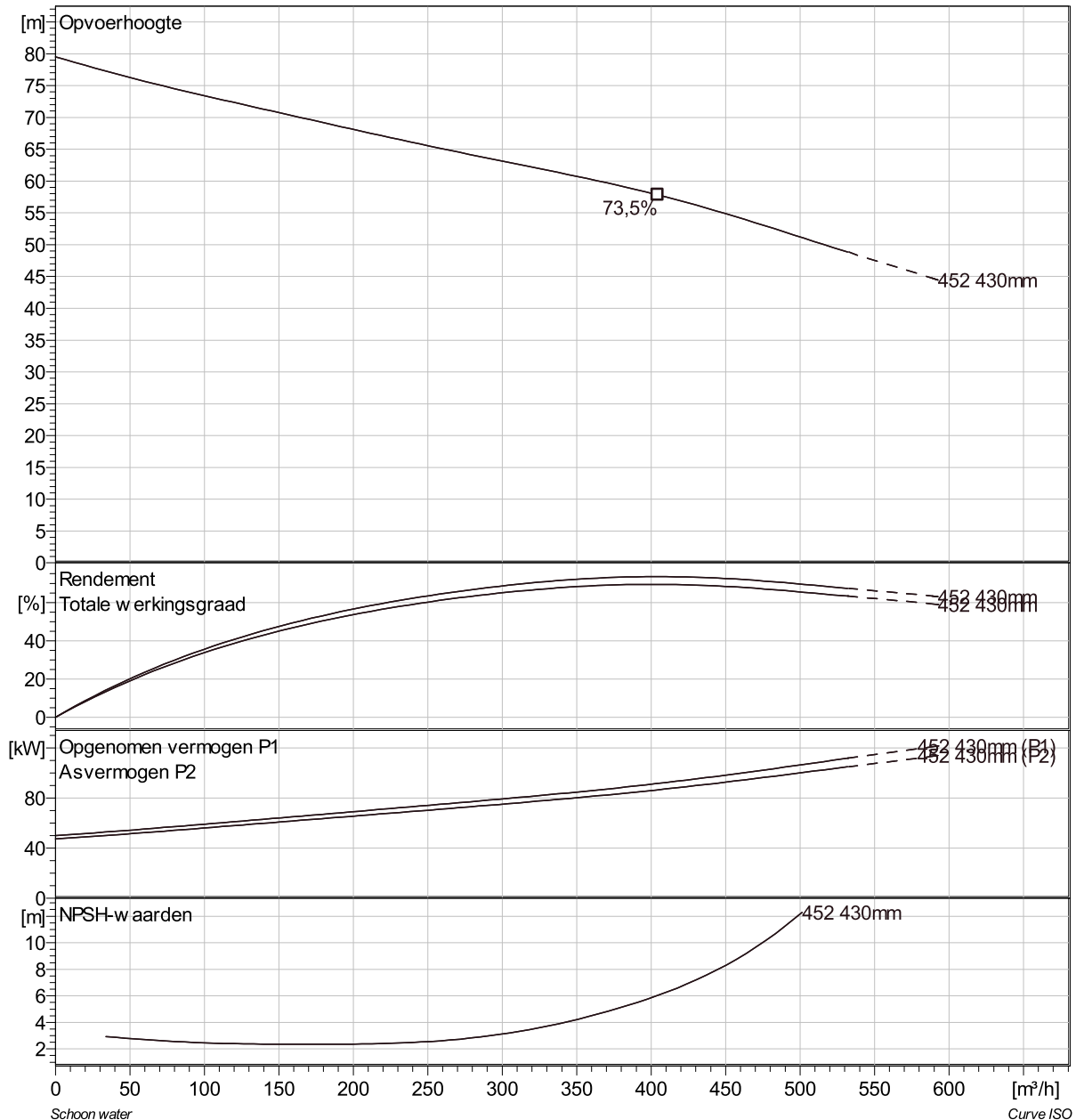

Project omschrijving	Projectnummer	Aangemaakt door:	Aangemaakt op 9/27/2018	Laatste wijziging
----------------------	---------------	------------------	----------------------------	-------------------

NP 3315 HT 3~ 452 VFD Analysis

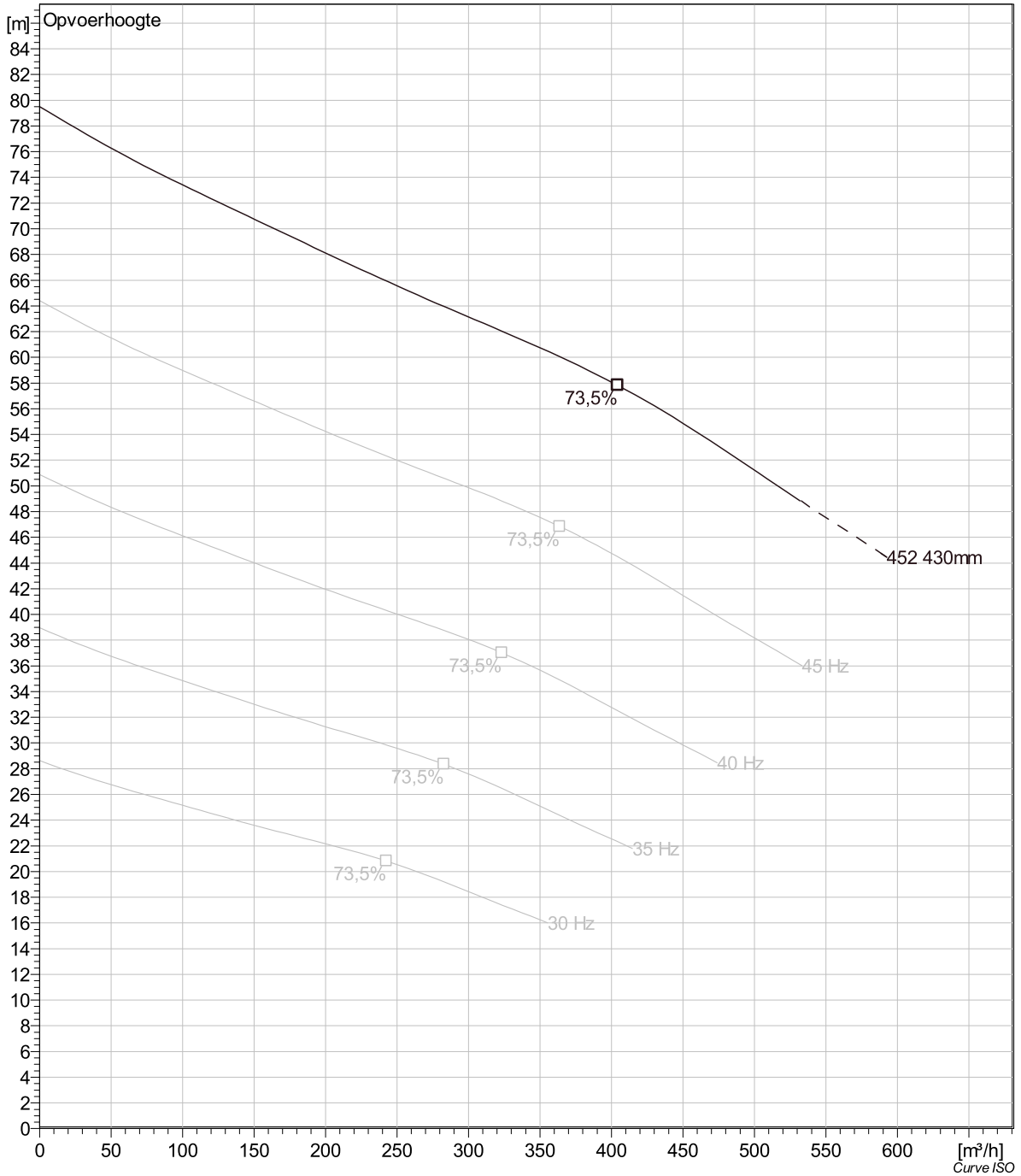

Project omschrijving	Projectnummer	Aangemaakt door:	Aangemaakt op 9/27/2018	Laatste wijziging
----------------------	---------------	------------------	----------------------------	-------------------

NP 3315 HT 3~ 452 Dimensional drawing

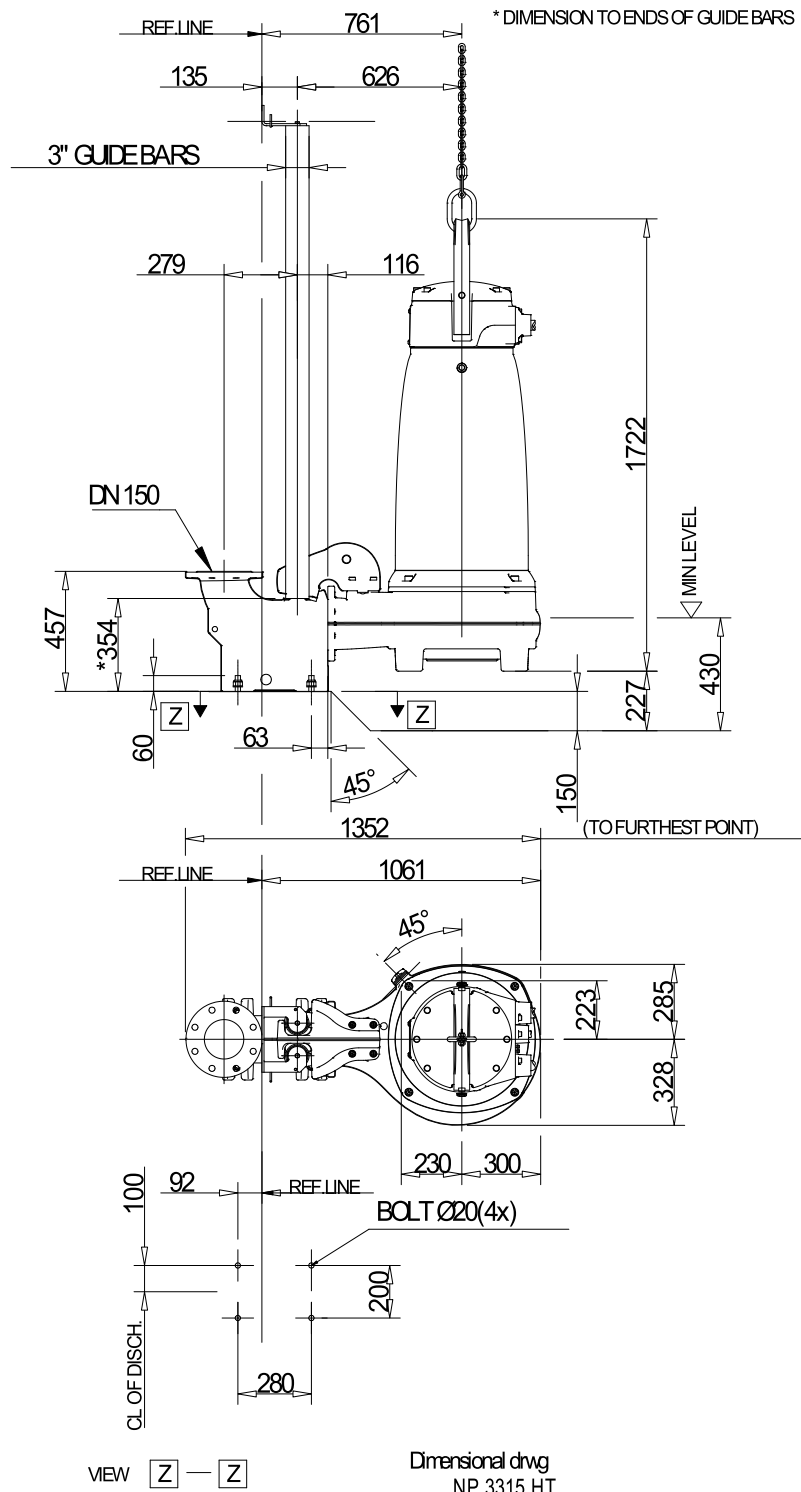

Project omschrijving	Projectnummer	Aangemaakt door:	Aangemaakt op 9/27/2018	Laatste wijziging
----------------------	---------------	------------------	----------------------------	-------------------