

NP 3315 LT 3~ 620 Technische specificaties

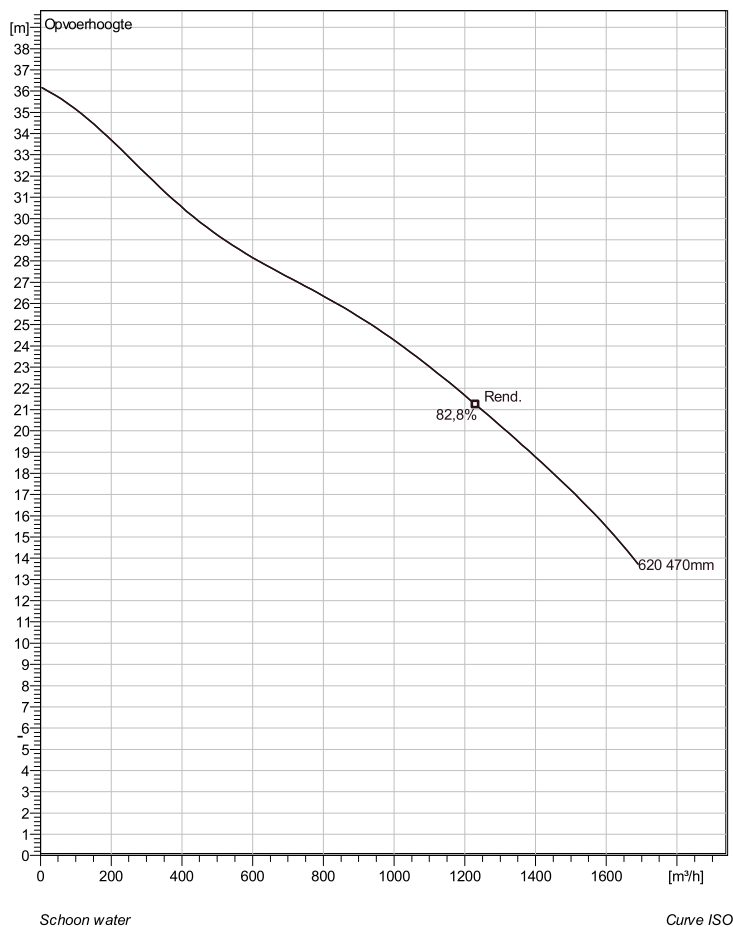

Note: Picture might not correspond to the current configuration.

General

Dompelbare pompen voorzien van verstopingsongevoeilige N-waaiers. Geschikt voor afvalwater met grotere delen zoals rioolwater, regenwater en industriële afvalwater. Materiaal gietijzer.

Impeller

Impeller material	Grey cast iron
Persaansluiting	300 mm
Diameter aanzuigzijde	300 mm
Impeller diameter	470 mm
Aantal bladen	3

Motor

Motor #	N3315.180 35-45-6AA-W 90KW standaard
Stator variant	1
Frequentie	50 Hz
Nominale spanning	400 V
Aantal polen	6
Fasen	3~
Nominaal vermogen	90 kW
Toegekende stroom	185 A
Aanloopstroom	1170 A
Nominaal toerental	985 rpm
Vermogensfactor	
1/1 Load	0,76
3/4 Load	0,70
1/2 Load	0,58
Motor efficiency	
1/1 Load	92,2 %
3/4 Load	92,6 %
1/2 Load	92,0 %

Soort installatie: Semi Permanent, Nat

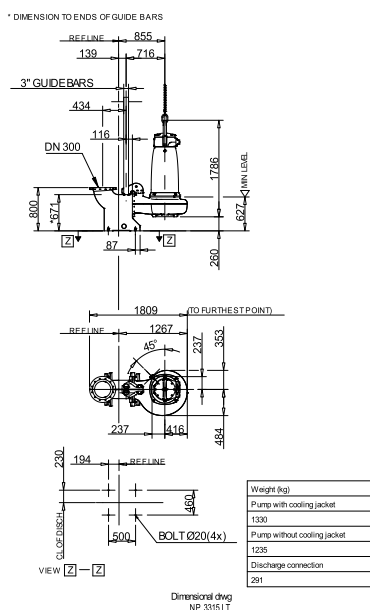

Project omschrijving	Projectnummer	Aangemaakt door:	Aangemaakt op 9/27/2018	Laatste wijziging
----------------------	---------------	------------------	----------------------------	-------------------

NP 3315 LT 3~ 620

Karakteristiek

Pomp

Persaansluiting 300 mm
 Diameter aanzuigzijde 300 mm
 Impeller diameter 470 mm
 Aantal bladen 3

Motor

Motor # N3315.180 35-45-6AA-W 90KW
 Stator variant 1
 Frequentie 50 Hz
 Nominale spanning 400 V
 Aantal polen 6
 Fasen 3~
 Nominaal vermogen 90 kW
 Toegekende stroom 185 A
 Aanloopstroom 1170 A
 Nominaal toerental 985 rpm

Vermogensfactor
 1/1 Load 0,76
 3/4 Load 0,70
 1/2 Load 0,58
 Motor efficiency
 1/1 Load 92,2 %
 3/4 Load 92,6 %
 1/2 Load 92,0 %

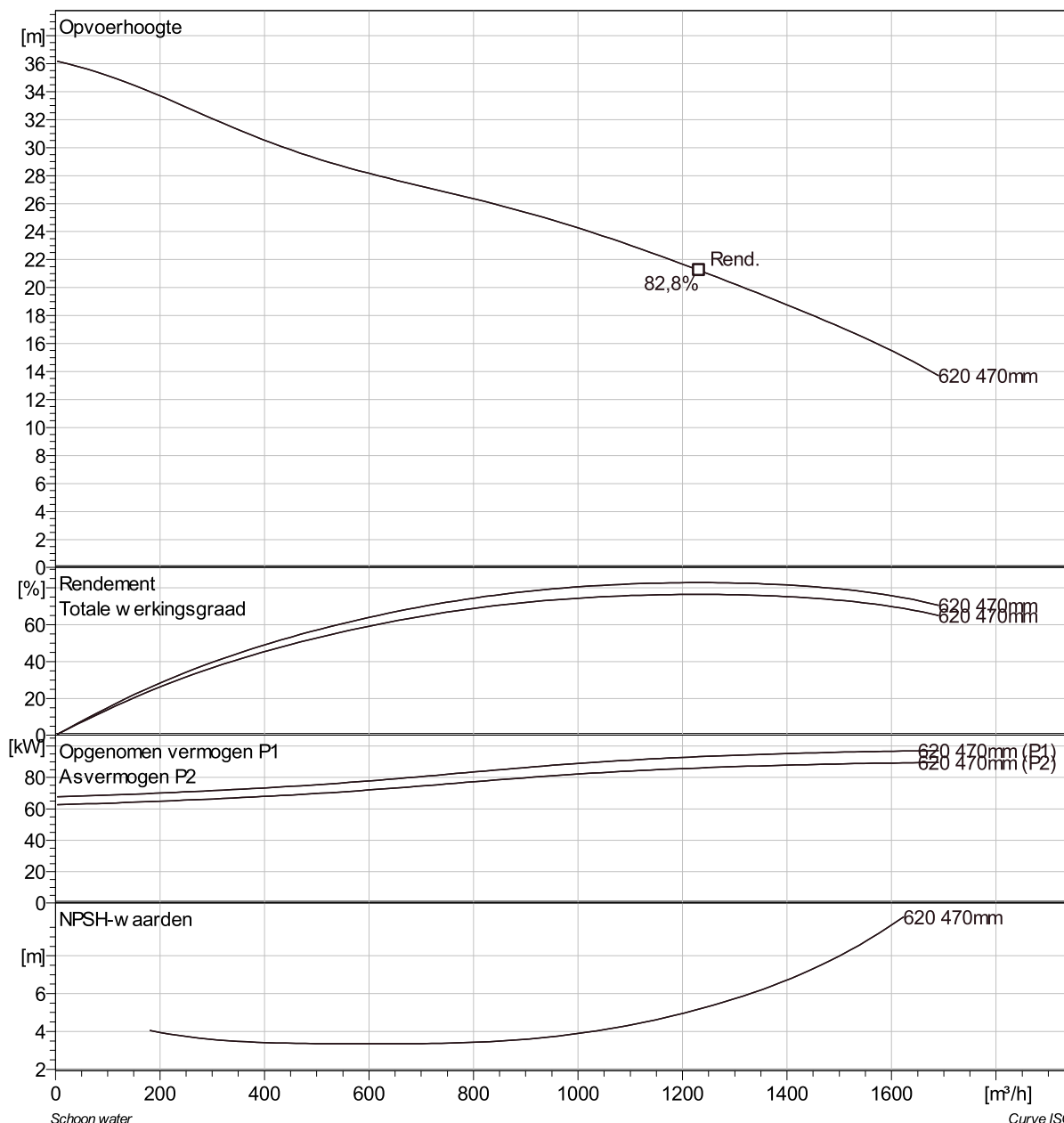

Project omschrijving	Projectnummer	Aangemaakt door:	Aangemaakt op 9/27/2018	Laatste wijziging
----------------------	---------------	------------------	----------------------------	-------------------

NP 3315 LT 3~ 620 VFD Analysis

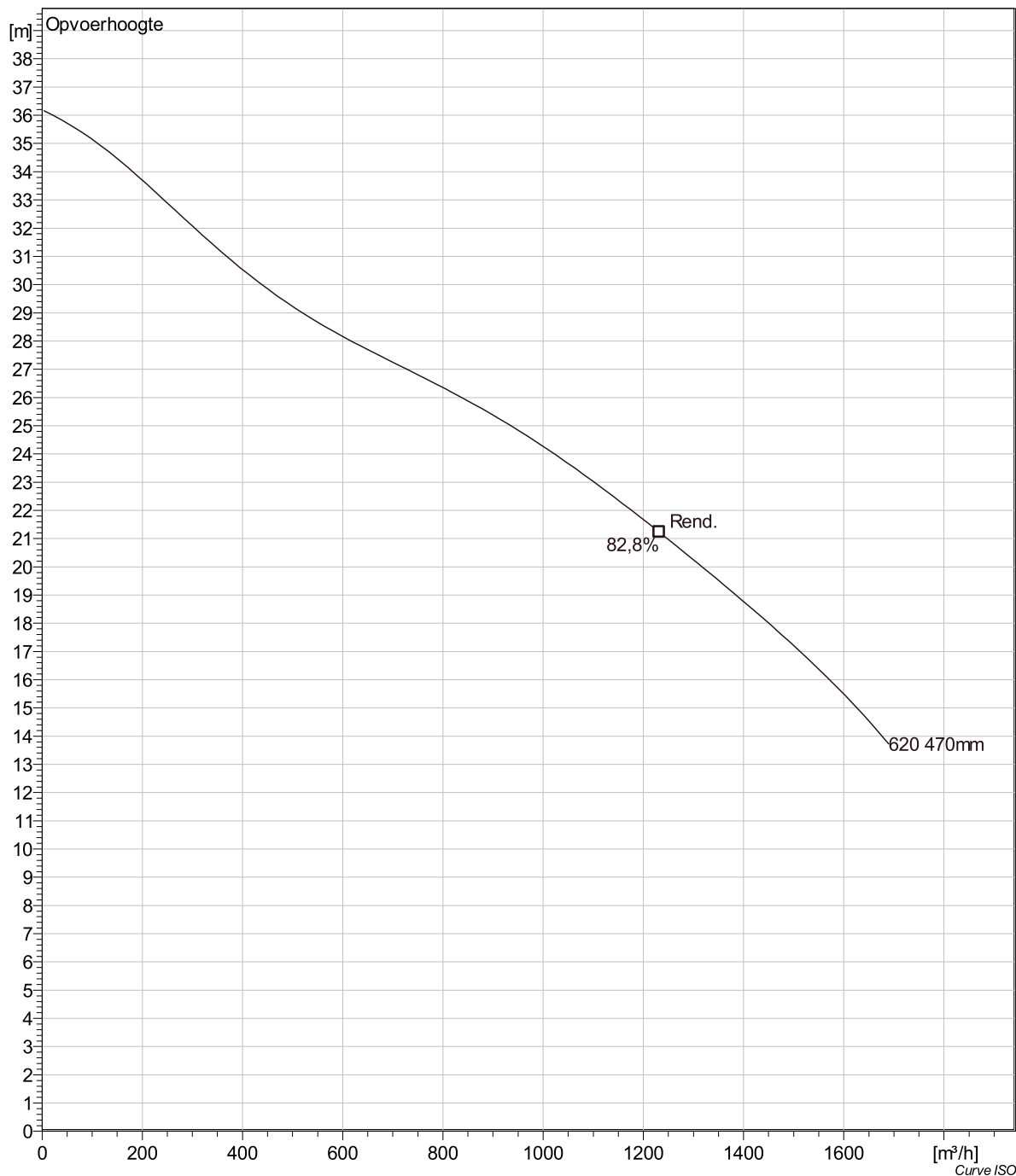

Project omschrijving	Projectnummer	Aangemaakt door:	Aangemaakt op 9/27/2018	Laatste wijziging
----------------------	---------------	------------------	----------------------------	-------------------

NP 3315 LT 3~ 620 Dimensional drawing



* DIMENSION TO ENDS OF GUIDE BARS

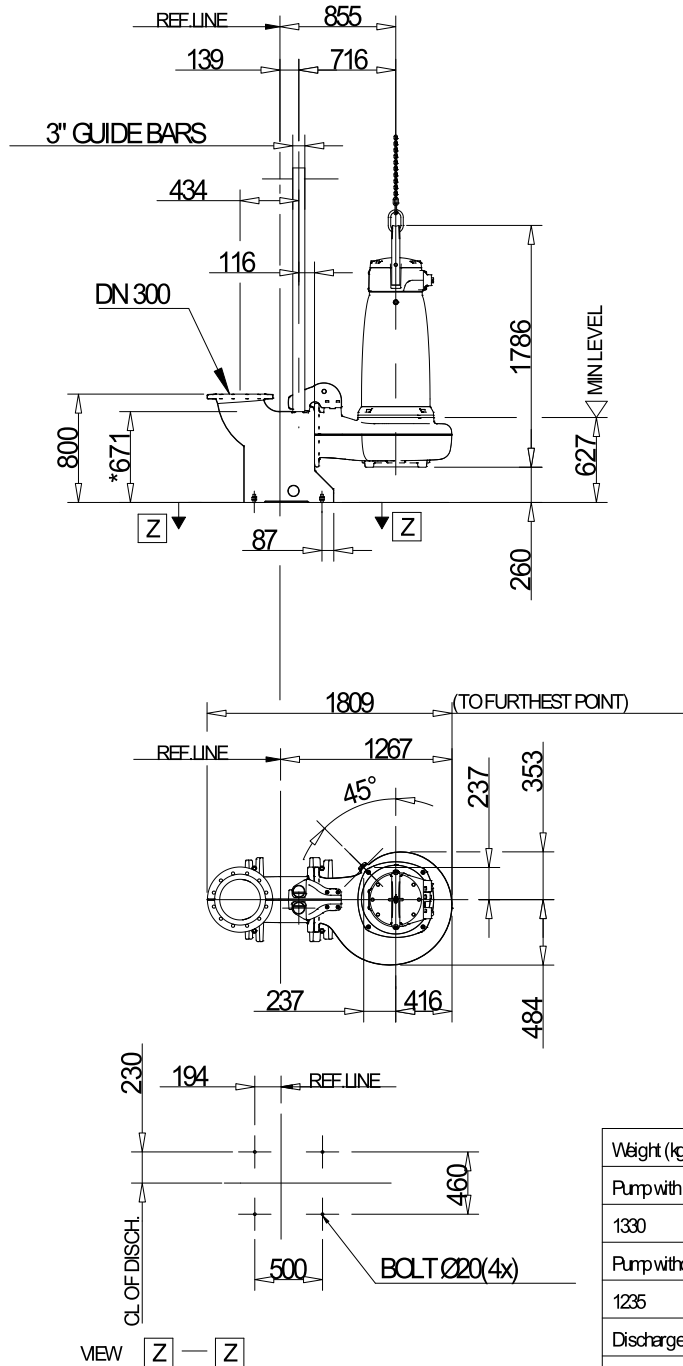

Dimensional drwg
NP 3315 LT

Weight (kg)
Pump with cooling jacket
1330
Pump without cooling jacket
1235
Discharge connection
291

Project omschrijving

Projectnummer

Aangemaakt door:

Aangemaakt op
9/27/2018

Laatste wijziging