

NP 3315 LT 3~ 623 Technische specificaties

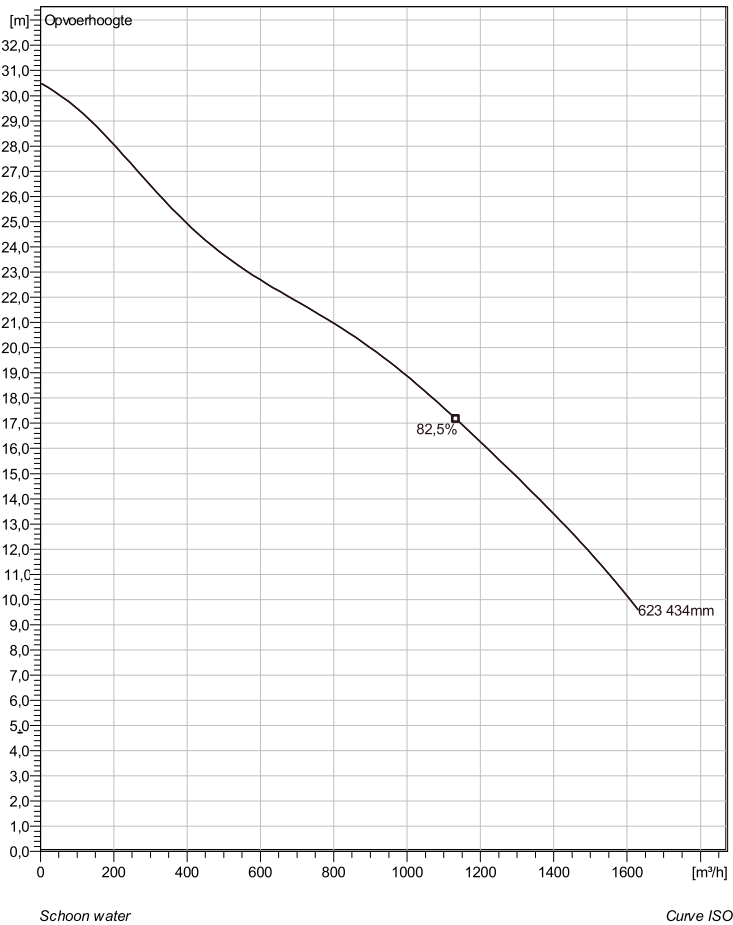

Note: Picture might not correspond to the current configuration.

General

Dompelbare pompen voorzien van een verstopingsongevoeilige N-waaiër. Geschikt voor afvalwater met grotere delen zoals rioolwater, regenwater en industriële afvalwater. Materiaal gietijzer.

Impeller

Impeller materiaal	Grey cast iron
Persaansluiting	300 mm
Diameter aanzuigzijde	300 mm
Impeller diameter	434 mm
Aantal bladen	3

Motor

Motor #	N3315.180 35-35-6AA-W 75KW standaard
Stator variant	1
Frequentie	50 Hz
Nominale spanning	400 V
Aantal polen	6
Fasen	3~
Nominaal vermogen	75 kW
Toegekende stroom	150 A
Aanloopstroom	935 A
Nominaal toerental	985 rpm
Vermogensfactor	
1/1 Load	0,79
3/4 Load	0,73
1/2 Load	0,62
Motor efficiency	
1/1 Load	91,2 %
3/4 Load	91,9 %
1/2 Load	91,7 %

Soort installatie: Semi Permanent, Nat

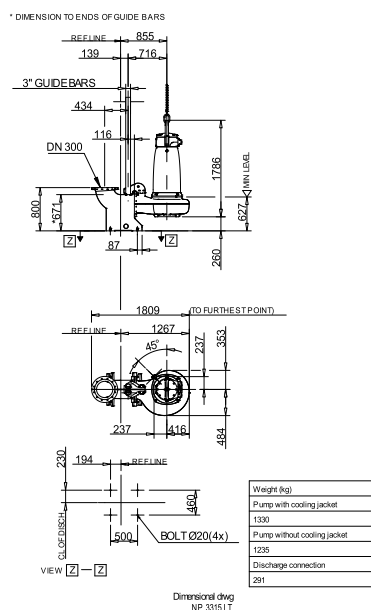

Project omschrijving	Projectnummer	Aangemaakt door:	Aangemaakt op 9/27/2018	Laatste wijziging
----------------------	---------------	------------------	----------------------------	-------------------

NP 3315 LT 3~ 623

Karakteristiek

Pomp

Persaansluiting	300 mm
Diameter aanzuigzijde	300 mm
Impeller diameter	434 mm
Aantal bladen	3

Motor

Motor #	N3315.180 35-35-6AA-W 75KW
Stator variant	1
Frequentie	50 Hz
Nominale spanning	400 V
Aantal polen	6
Fasen	3~
Nominaal vermogen	75 kW
Toegekende stroom	150 A
Aanloopstroom	935 A
Nominaal toerental	985 rpm

Vermogensfactor	
1/1 Load	0,79
3/4 Load	0,73
1/2 Load	0,62
Motor efficiency	
1/1 Load	91,2 %
3/4 Load	91,9 %
1/2 Load	91,7 %

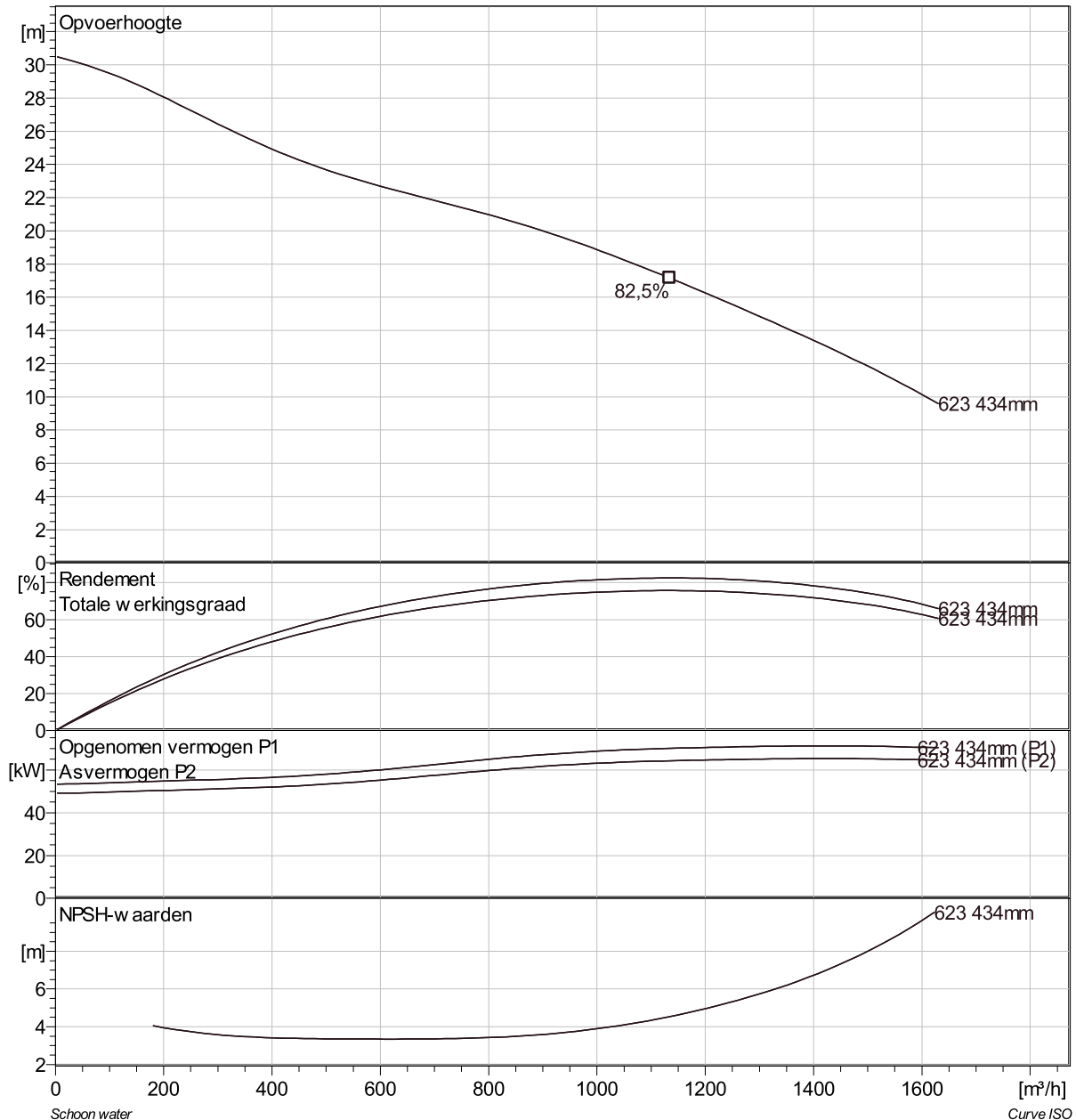

Project omschrijving	Projectnummer	Aangemaakt door:	Aangemaakt op 9/27/2018	Laatste wijziging
----------------------	---------------	------------------	----------------------------	-------------------

NP 3315 LT 3~ 623

VFD Analysis

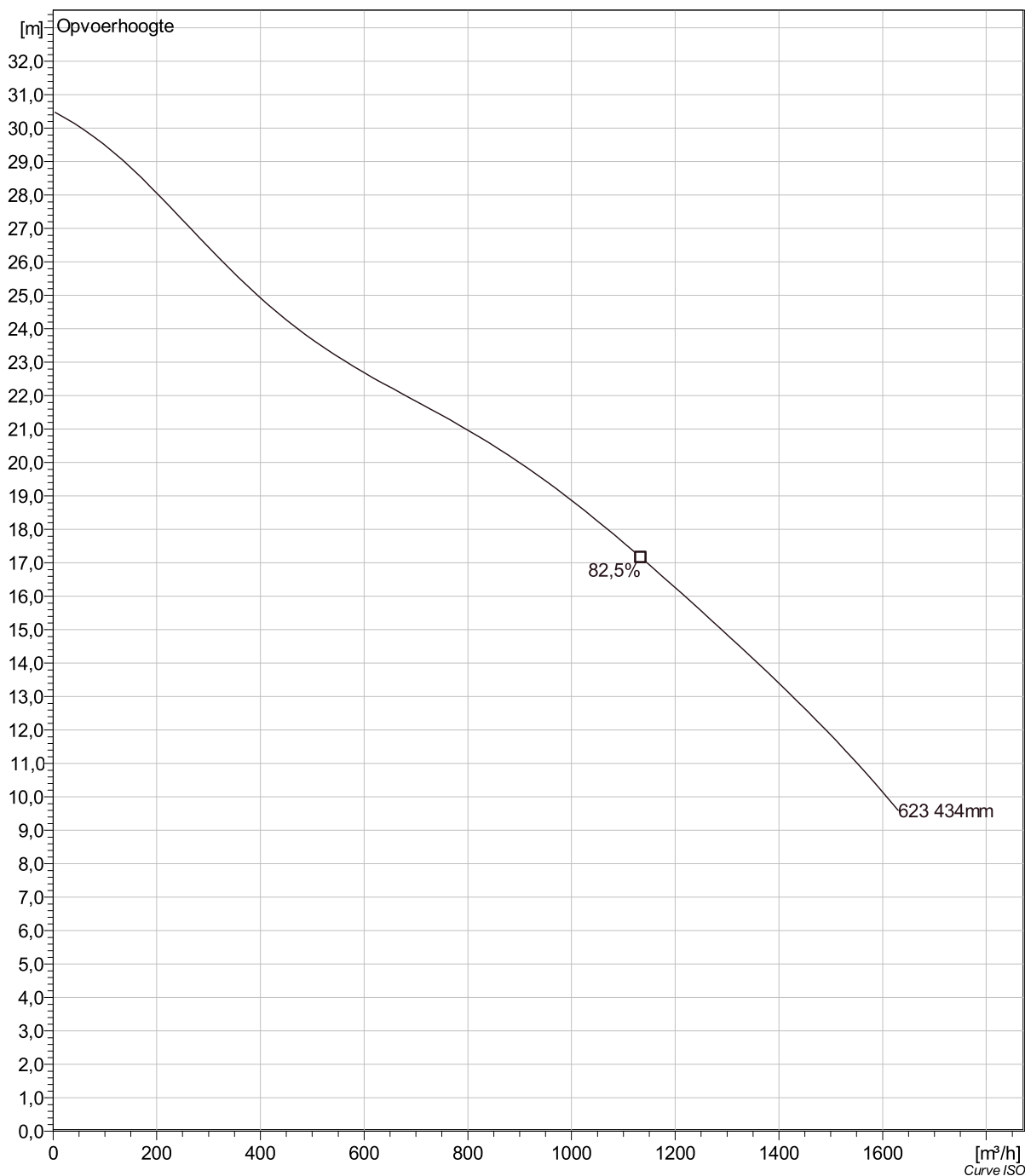

Project omschrijving	Projectnummer	Aangemaakt door:	Aangemaakt op 9/27/2018	Laatste wijziging
----------------------	---------------	------------------	----------------------------	-------------------

NP 3315 LT 3~ 623 Dimensional drawing



* DIMENSION TO ENDS OF GUIDE BARS

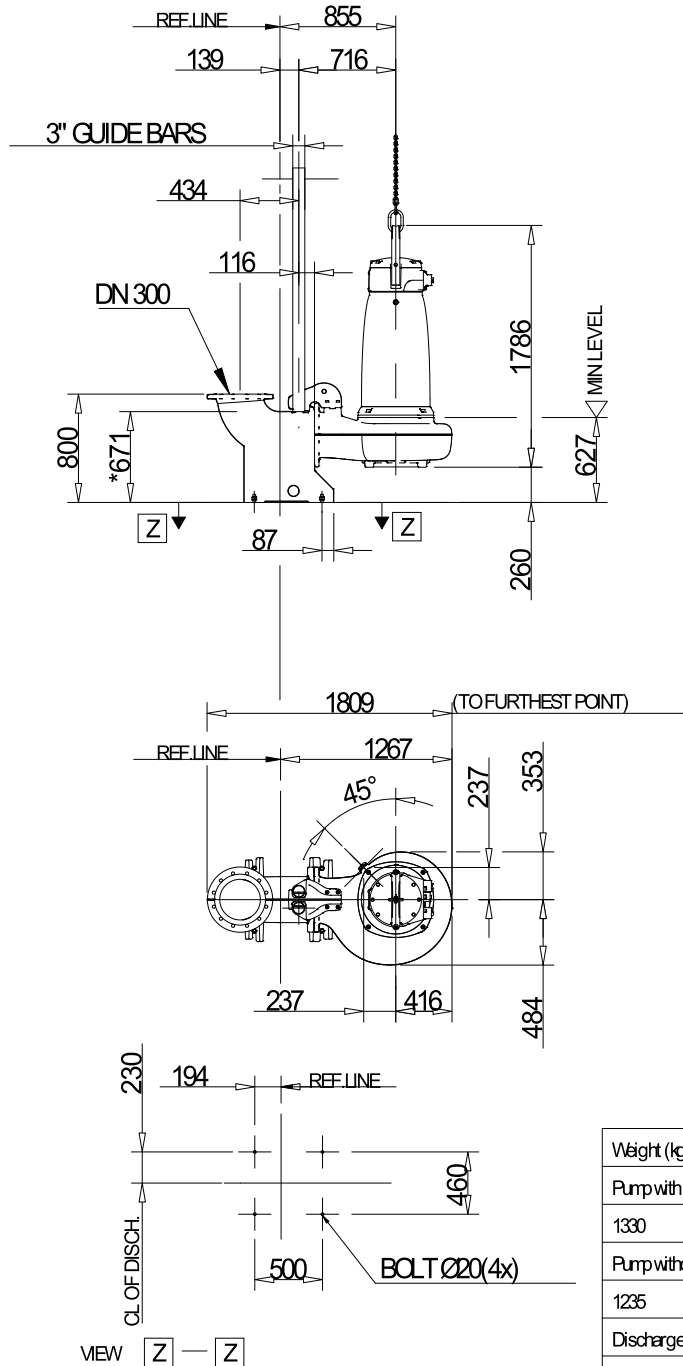

Dimensional drwg
NP 3315 LT

Weight (kg)
Pump with cooling jacket
1330
Pump without cooling jacket
1235
Discharge connection
291

Project omschrijving	Projectnummer	Aangemaakt door:	Aangemaakt op 9/27/2018	Laatste wijziging
----------------------	---------------	------------------	----------------------------	-------------------