

NP 3315 LT 3~ 813 Technische specificaties

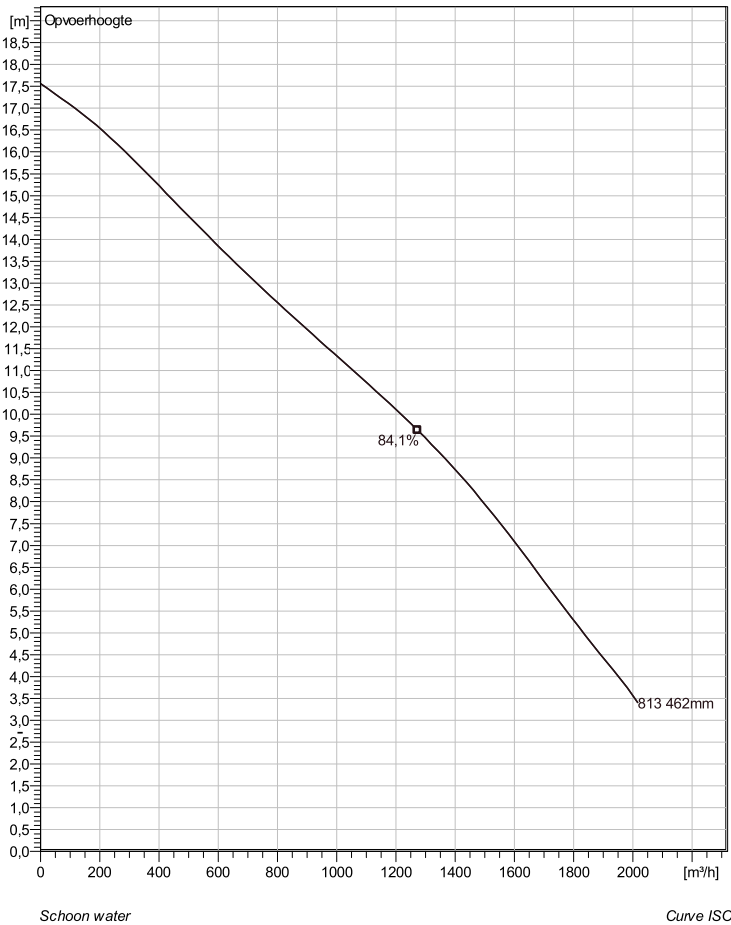

Note: Picture might not correspond to the current configuration.

General

Dompelbare pompen voorzien van een verstoppingsongevoeilige N-waaiër. Geschikt voor afvalwater met grotere delen zoals rioolwater, regenwater en industriële afvalwater. Materiaal gietijzer.

Impeller

Impeller material	Grey cast iron
Persaansluiting	350 mm
Diameter aanzuigzijde	350 mm
Impeller diameter	462 mm
Aantal bladen	3

Motor

Motor #	N3315.180 35-35-8AA-W 48KW standaard
Stator variant	1
Frequentie	50 Hz
Nominale spanning	400 V
Aantal polen	8
Fasen	3~
Nominaal vermogen	48 kW
Toegekende stroom	102 A
Aanloopstroom	525 A
Nominaal toerental	735 rpm
Vermogensfactor	
1/1 Load	0,75
3/4 Load	0,70
1/2 Load	0,59
Motor efficiency	
1/1 Load	90,0 %
3/4 Load	90,5 %
1/2 Load	90,0 %

Soort installatie: Semi Permanent, Nat

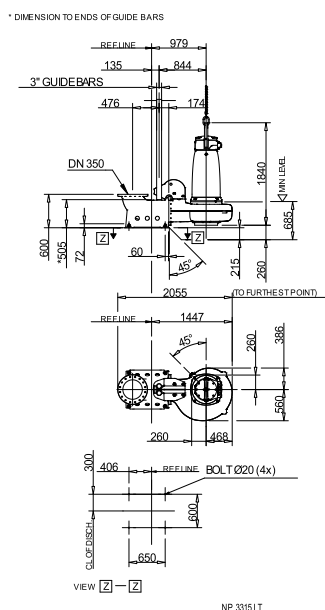

Project omschrijving	Projectnummer	Aangemaakt door:	Aangemaakt op 9/27/2018	Laatste wijziging
----------------------	---------------	------------------	----------------------------	-------------------

NP 3315 LT 3~ 813

Karakteristiek

Pomp

Persaansluiting	350 mm
Diameter aanzuigzijde	350 mm
Impeller diameter	462 mm
Aantal bladen	3

Motor

Motor #	N3315.180 35-35-8AA-W 48KW
Stator variant	1
Frequentie	50 Hz
Nominale spanning	400 V
Aantal polen	8
Fasen	3~
Nominaal vermogen	48 kW
Toegekende stroom	102 A
Aanloopstroom	525 A
Nominaal toerental	735 rpm

Vermogensfactor	
1/1 Load	0,75
3/4 Load	0,70
1/2 Load	0,59
Motor efficiency	
1/1 Load	90,0 %
3/4 Load	90,5 %
1/2 Load	90,0 %

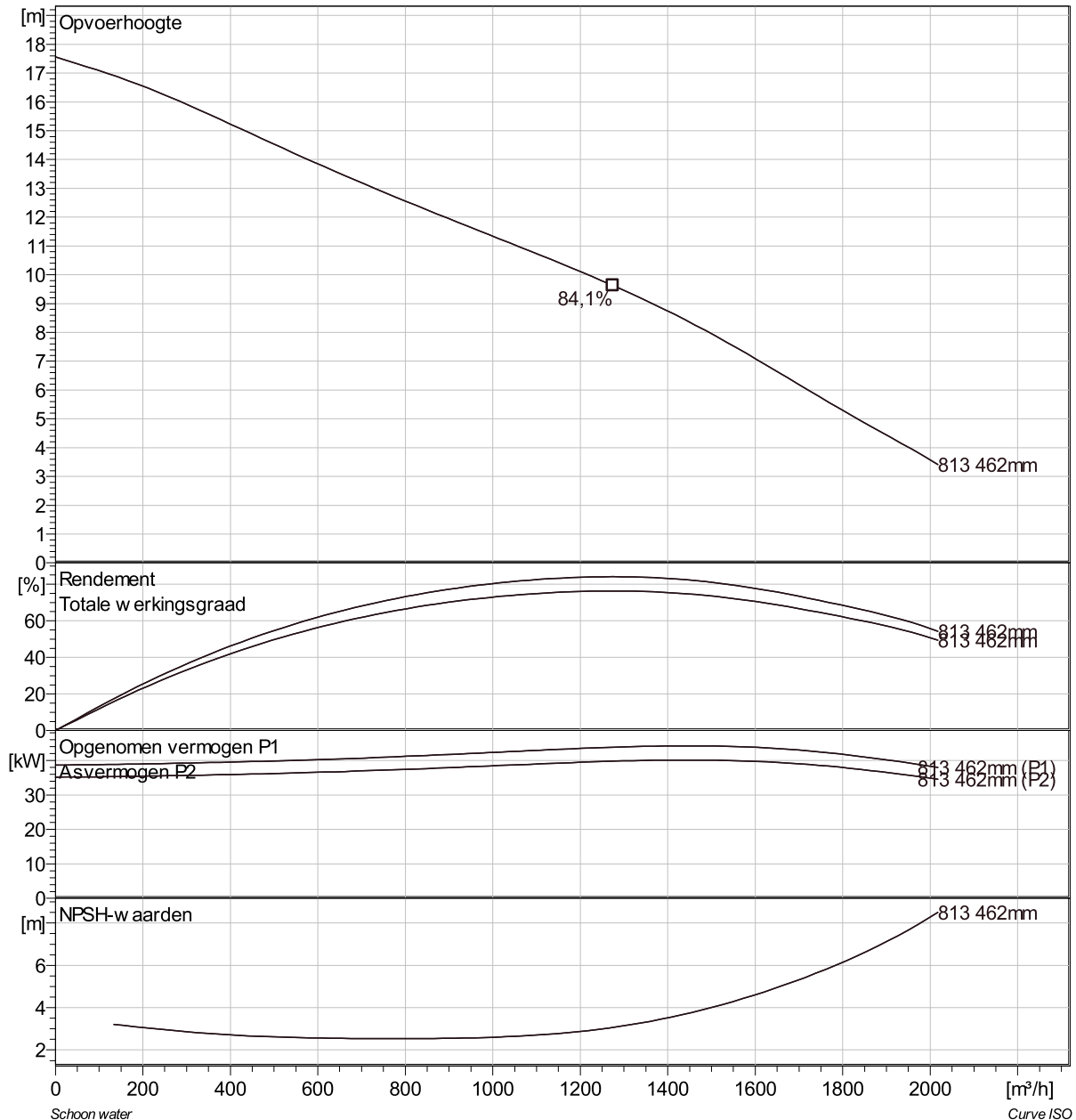

Project omschrijving	Projectnummer	Aangemaakt door:	Aangemaakt op 9/27/2018	Laatste wijziging
----------------------	---------------	------------------	----------------------------	-------------------

NP 3315 LT 3~ 813

VFD Analysis

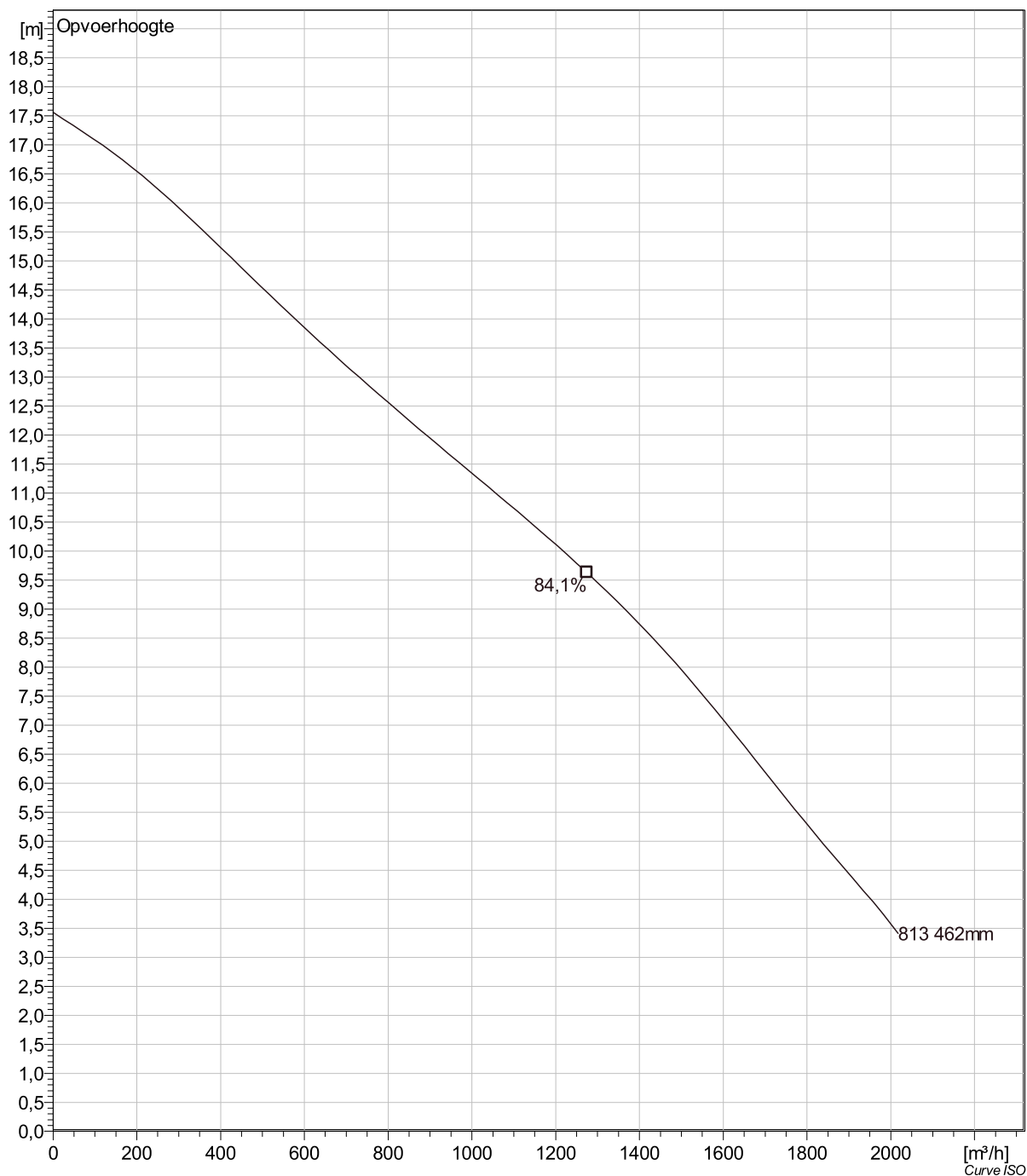

Project omschrijving	Projectnummer	Aangemaakt door:	Aangemaakt op 9/27/2018	Laatste wijziging
----------------------	---------------	------------------	----------------------------	-------------------

NP 3315 LT 3~ 813 Dimensional drawing



* DIMENSION TO ENDS OF GUIDE BARS

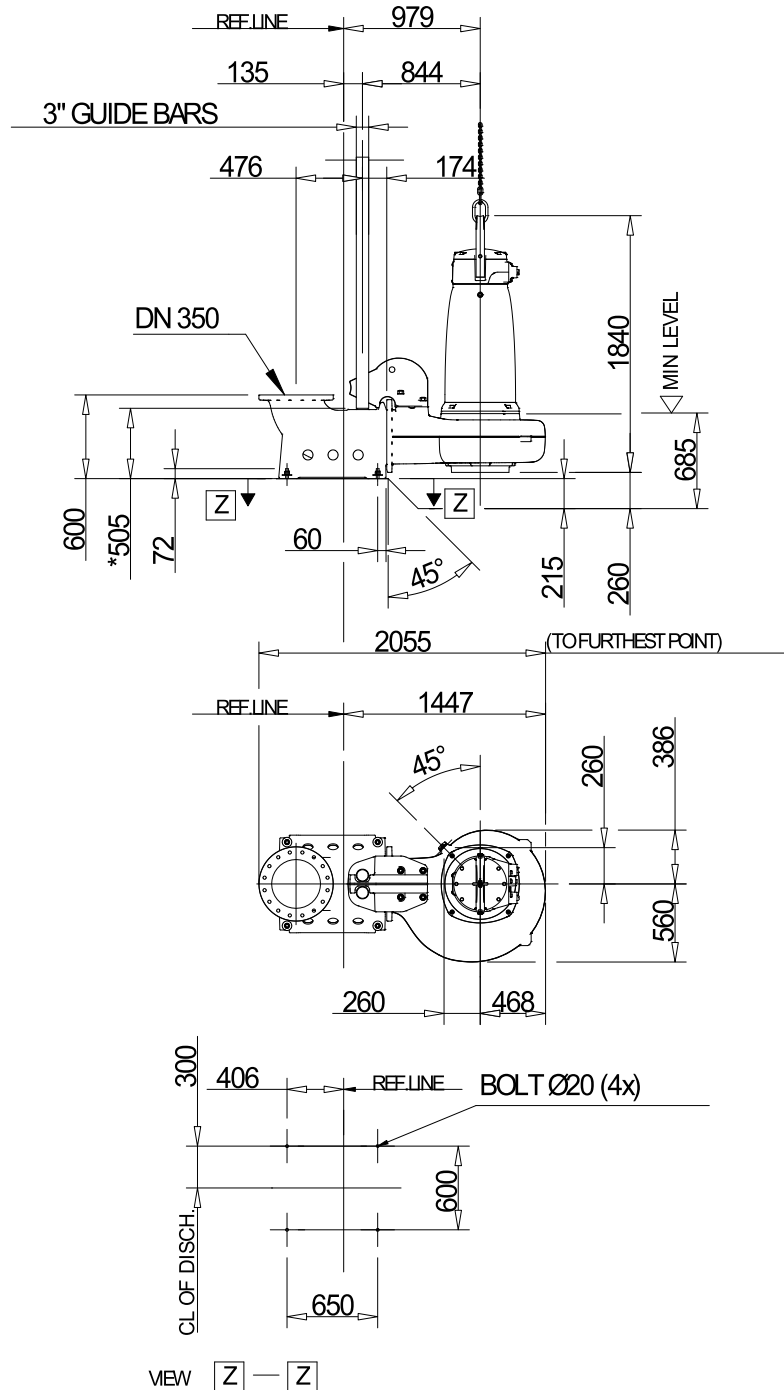

NP3315LT

Project omschrijving	Projectnummer	Aangemaakt door:	Aangemaakt op 9/27/2018	Laatste wijziging
----------------------	---------------	------------------	----------------------------	-------------------