

## NP 3315 MT 3~ 631 Technische specificaties

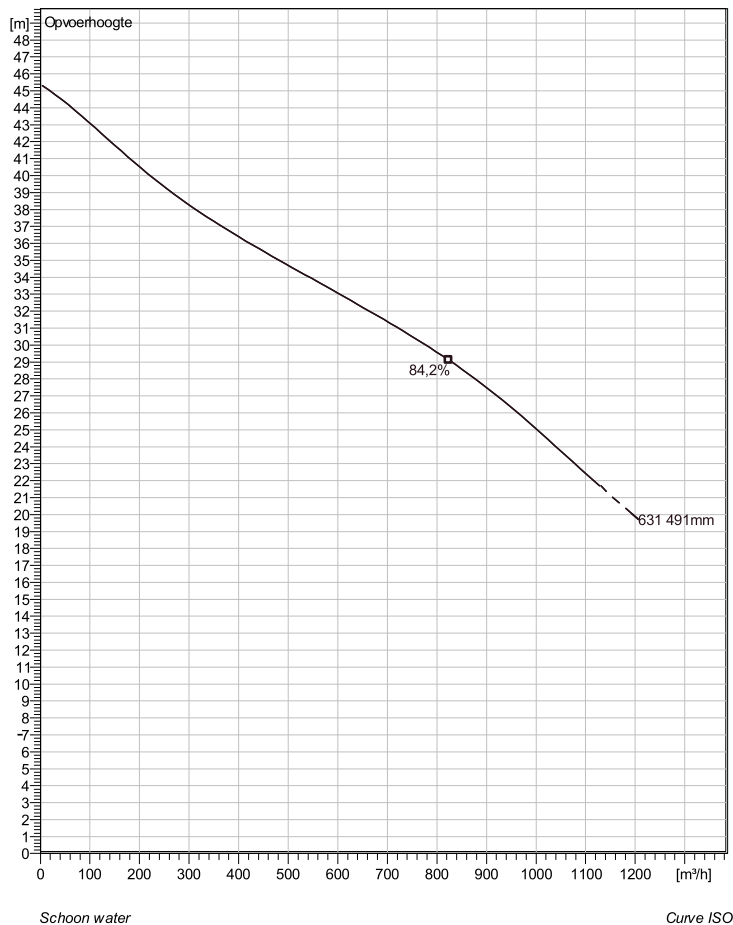

Note: Picture might not correspond to the current configuration.

### General

Dompelbare pompen voorzien van een verstopingsongevoeilige N-waaiër. Geschikt voor afvalwater met grotere delen zoals rioolwater, regenwater en industriële afvalwater. Materiaal gietijzer.

### Impeller

Impeller material	Grey cast iron
Persaansluiting	250 mm
Diameter aanzuigzijde	250 mm
Impeller diameter	491 mm
Aantal bladen	3

### Motor

Motor #	N3315.180 35-45-6AA-W 90KW standaard
Stator variant	1
Frequentie	50 Hz
Nominale spanning	400 V
Aantal polen	6
Fasen	3~
Nominaal vermogen	90 kW
Toegekende stroom	185 A
Aanloopstroom	1170 A
Nominaal toerental	985 rpm
Vermogensfactor	
1/1 Load	0,76
3/4 Load	0,70
1/2 Load	0,58
Motor efficiency	
1/1 Load	92,2 %
3/4 Load	92,6 %
1/2 Load	92,0 %

### Soort installatie: Semi Permanent, Nat

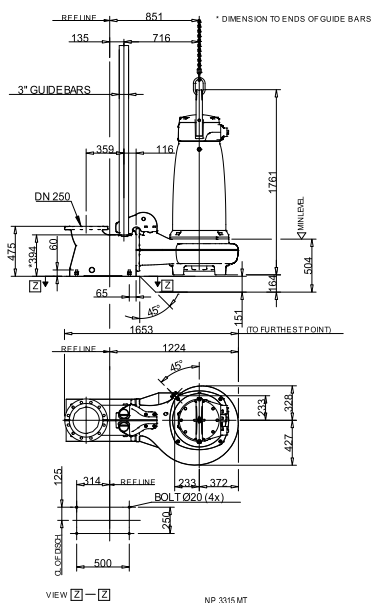

Project omschrijving	Projectnummer	Aangemaakt door:	Aangemaakt op 9/27/2018	Laatste wijziging
----------------------	---------------	------------------	----------------------------	-------------------

## NP 3315 MT 3~ 631

### Karakteristiek

#### Pomp

Persaansluiting	250 mm
Diameter aanzuigzijde	250 mm
Impeller diameter	491 mm
Aantal bladen	3

#### Motor

Motor #	N3315.180 35-45-6AA-W 90KW
Stator variant	1
Frequentie	50 Hz
Nominale spanning	400 V
Aantal polen	6
Fasen	3~
Nominaal vermogen	90 kW
Toegekende stroom	185 A
Aanloopstroom	1170 A
Nominaal toerental	985 rpm

Vermogensfactor	
1/1 Load	0,76
3/4 Load	0,70
1/2 Load	0,58
Motor efficiency	
1/1 Load	92,2 %
3/4 Load	92,6 %
1/2 Load	92,0 %

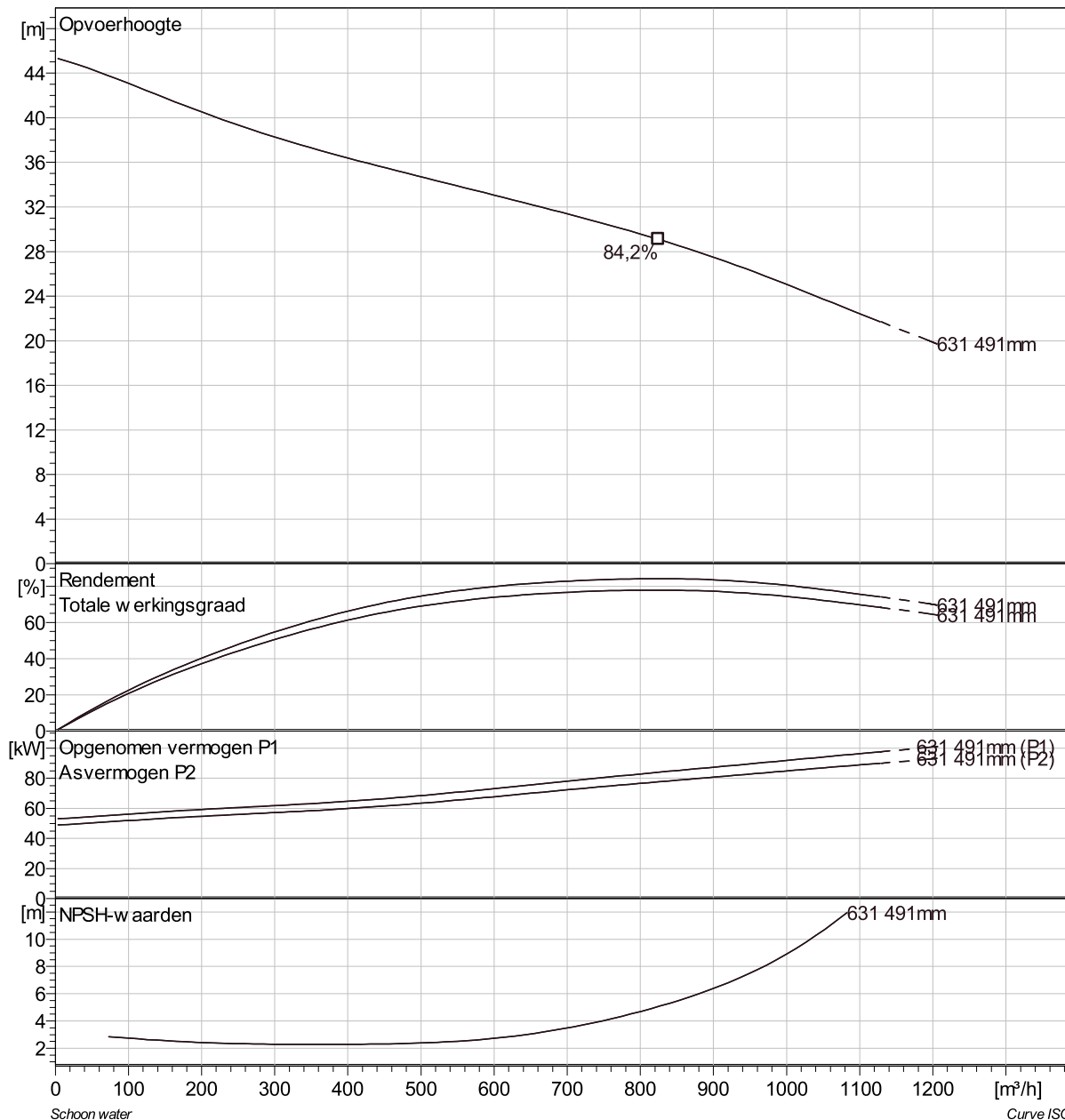

Project omschrijving	Projectnummer	Aangemaakt door:	Aangemaakt op 9/27/2018	Laatste wijziging
----------------------	---------------	------------------	----------------------------	-------------------

## NP 3315 MT 3~ 631 VFD Analysis

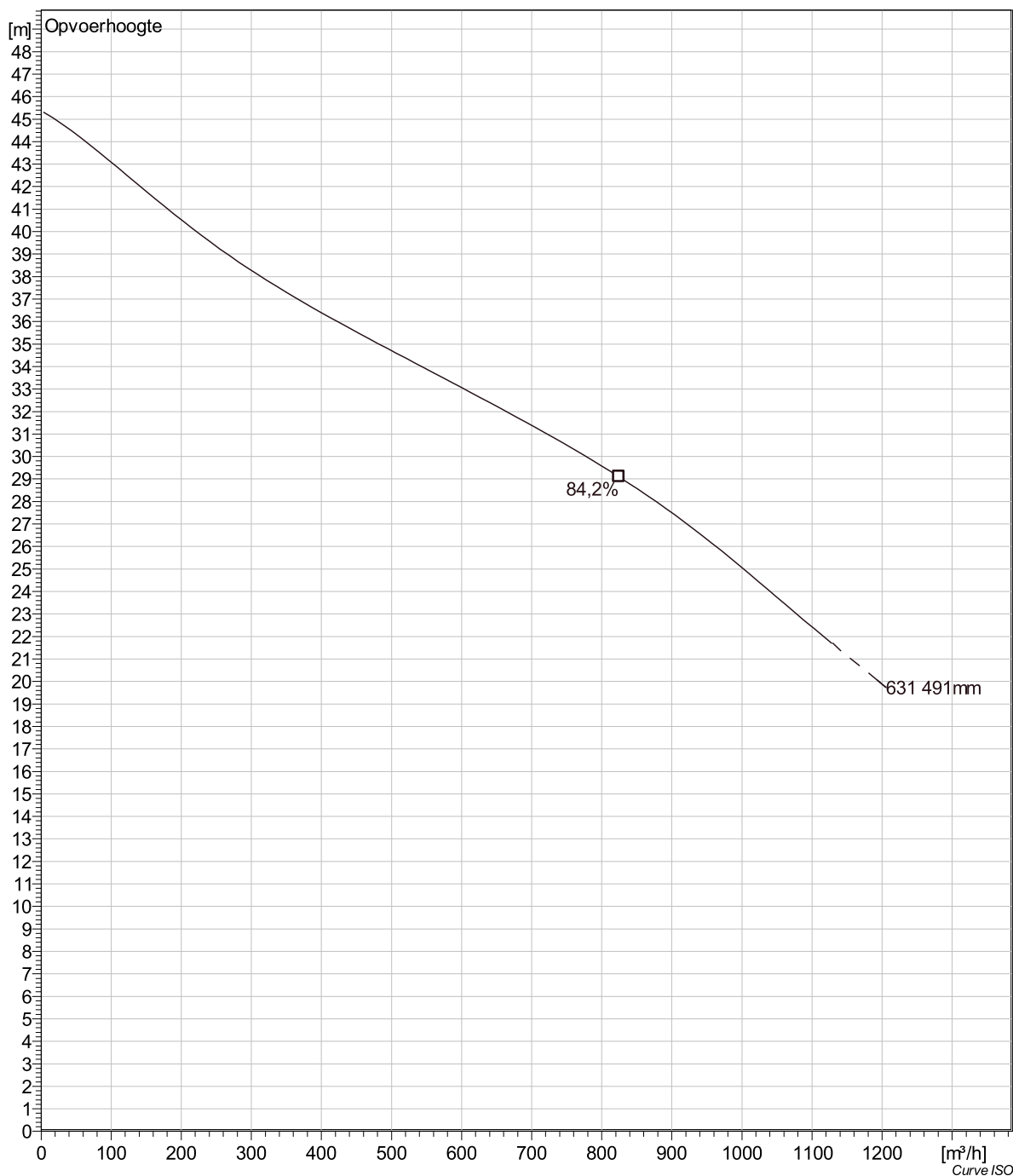

Project omschrijving	Projectnummer	Aangemaakt door:	Aangemaakt op 9/27/2018	Laatste wijziging
----------------------	---------------	------------------	----------------------------	-------------------

## NP 3315 MT 3~ 631 Dimensional drawing

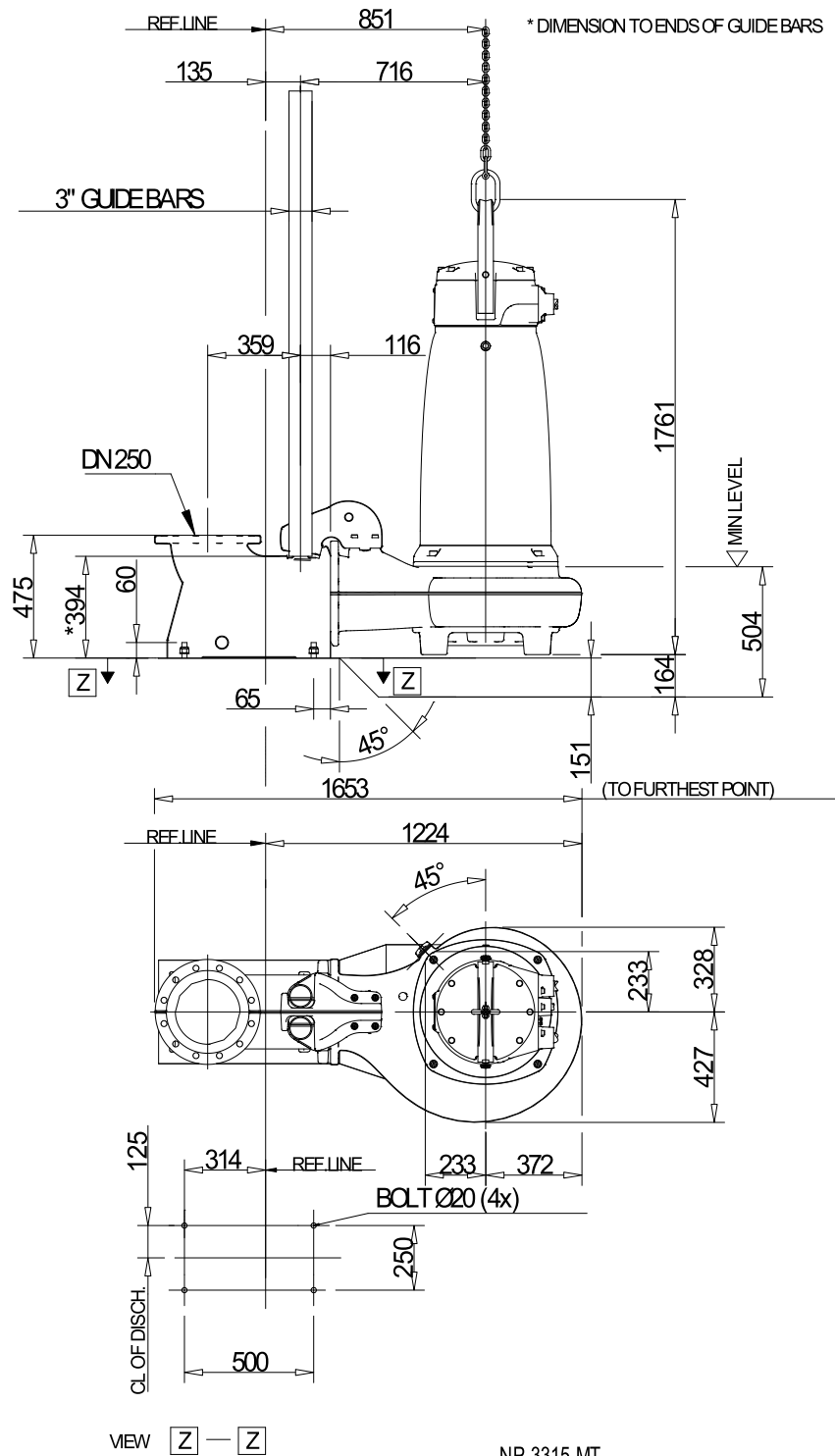

Project omschrijving	Projectnummer	Aangemaakt door:	Aangemaakt op 9/27/2018	Laatste wijziging
----------------------	---------------	------------------	----------------------------	-------------------