

NP 3315 MT 3~ 632 Technische specificaties

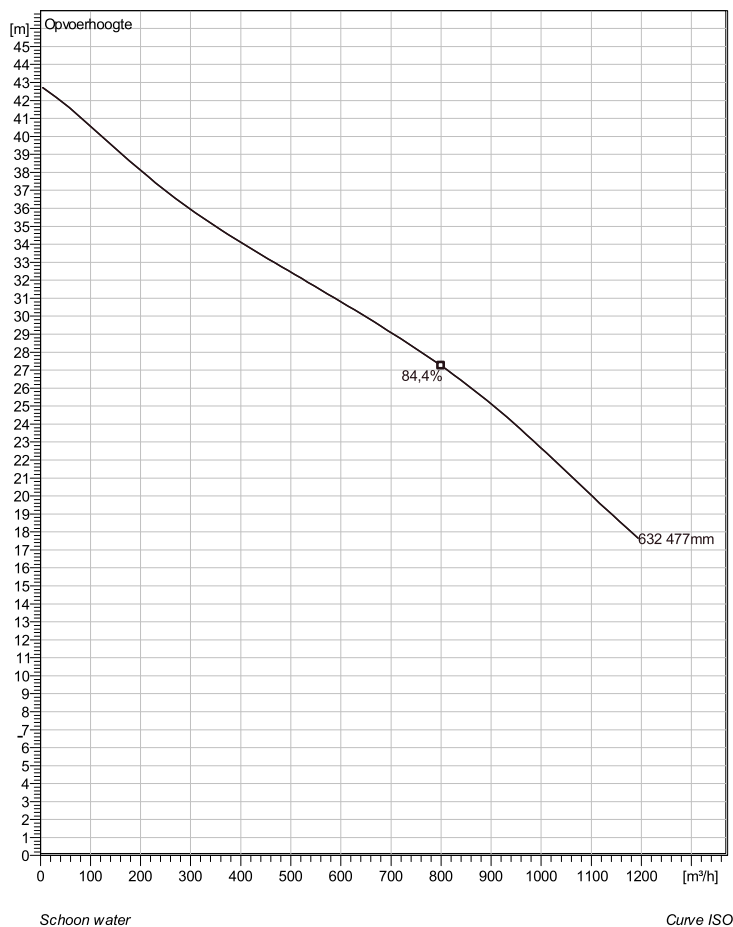

Note: Picture might not correspond to the current configuration.

General

Dompelbare pompen voorzien van een verstopingsgevoelige N-waaiër. Geschikt voor afvalwater met grotere delen zoals rioolwater, regenwater en industriële afvalwater. Materiaal gietijzer.

Impeller

Impeller material	Grey cast iron
Persaansluiting	250 mm
Diameter aanzuigzijde	250 mm
Impeller diameter	477 mm
Aantal bladen	3

Motor

Motor #	N3315.180 35-45-6AA-W 90KW standaard
Stator variant	1
Frequentie	50 Hz
Nominale spanning	400 V
Aantal polen	6
Fasen	3~
Nominaal vermogen	90 kW
Toegekende stroom	185 A
Aanlooptroom	1170 A
Nominaal toerental	985 rpm
Vermogensfactor	
1/1 Load	0,76
3/4 Load	0,70
1/2 Load	0,58
Motor efficiency	
1/1 Load	92,2 %
3/4 Load	92,6 %
1/2 Load	92,0 %

Soort installatie: Semi Permanent, Nat

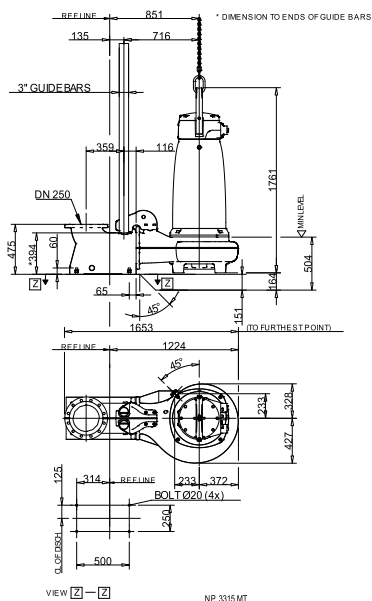

Project omschrijving	Projectnummer	Aangemaakt door:	Aangemaakt op 9/27/2018	Laatste wijziging
----------------------	---------------	------------------	----------------------------	-------------------

NP 3315 MT 3~ 632

Karakteristiek

Pomp

Persaansluiting	250 mm
Diameter aanzuigzijde	250 mm
Impeller diameter	477 mm
Aantal bladen	3

Motor

Motor #	N3315.180 35-45-6AA-W 90KW
Stator variant	1
Frequentie	50 Hz
Nominale spanning	400 V
Aantal polen	6
Fasen	3~
Nominaal vermogen	90 kW
Toegekende stroom	185 A
Aanloopstroom	1170 A
Nominaal toerental	985 rpm

Vermogensfactor	
1/1 Load	0,76
3/4 Load	0,70
1/2 Load	0,58
Motor efficiency	
1/1 Load	92,2 %
3/4 Load	92,6 %
1/2 Load	92,0 %

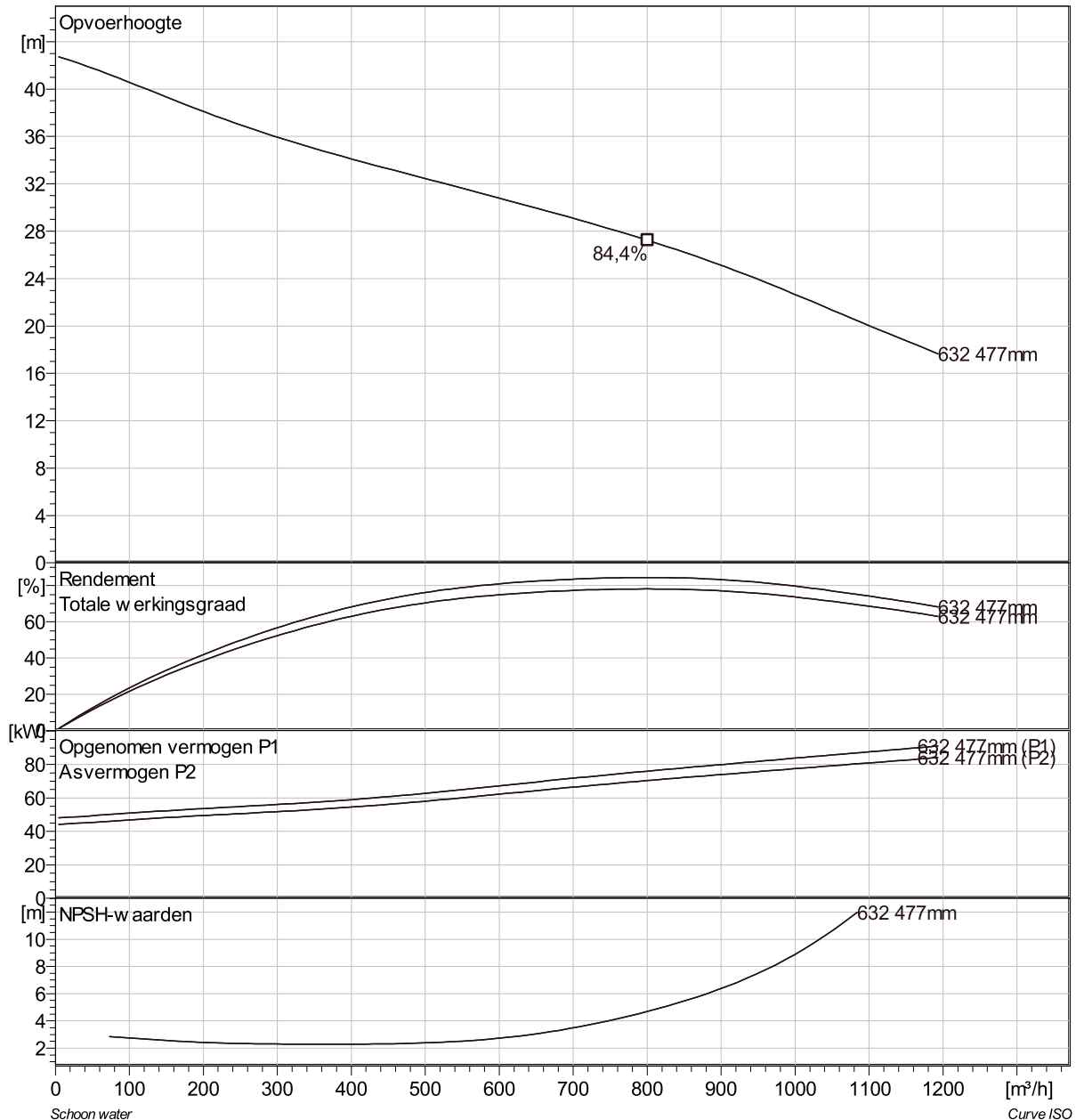

Project omschrijving	Projectnummer	Aangemaakt door:	Aangemaakt op 9/27/2018	Laatste wijziging
----------------------	---------------	------------------	----------------------------	-------------------

NP 3315 MT 3~ 632 VFD Analysis

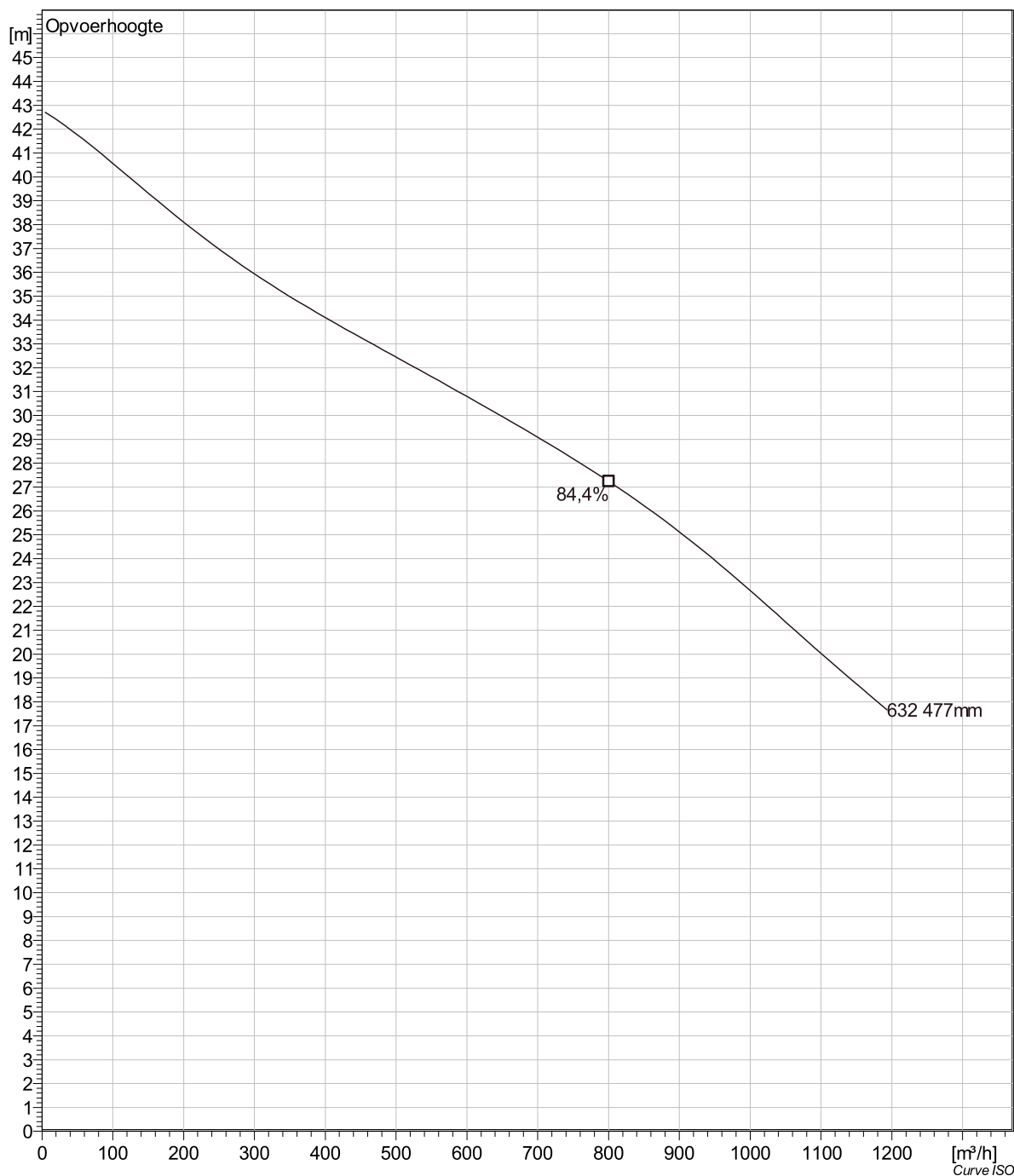

Project omschrijving	Projectnummer	Aangemaakt door:	Aangemaakt op 9/27/2018	Laatste wijziging
----------------------	---------------	------------------	----------------------------	-------------------

NP 3315 MT 3~ 632 Dimensional drawing

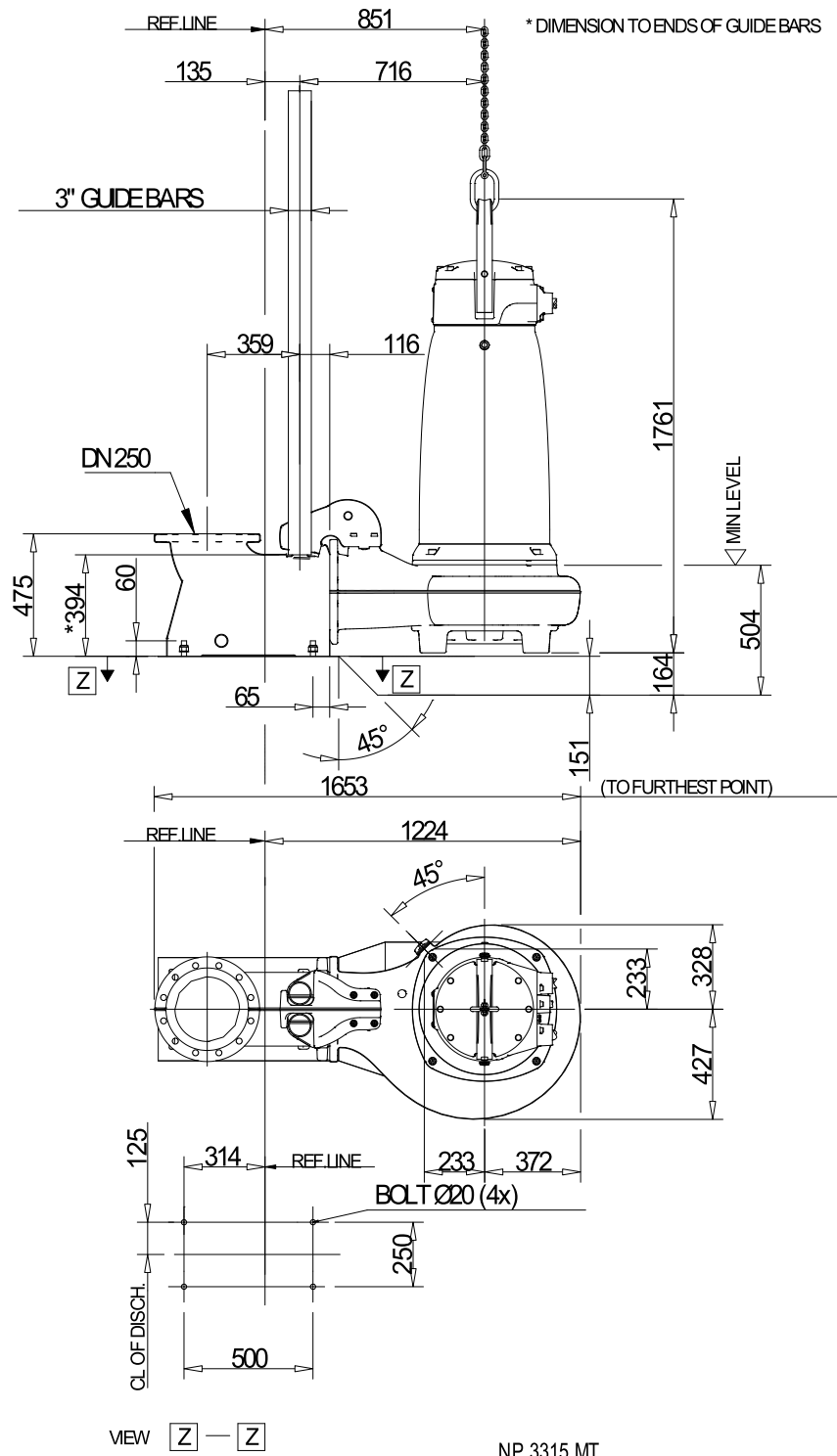

Project omschrijving	Projectnummer	Aangemaakt door:	Aangemaakt op 9/27/2018	Laatste wijziging
----------------------	---------------	------------------	----------------------------	-------------------