

NP 3315 MT 3~ 635 Technische specificaties

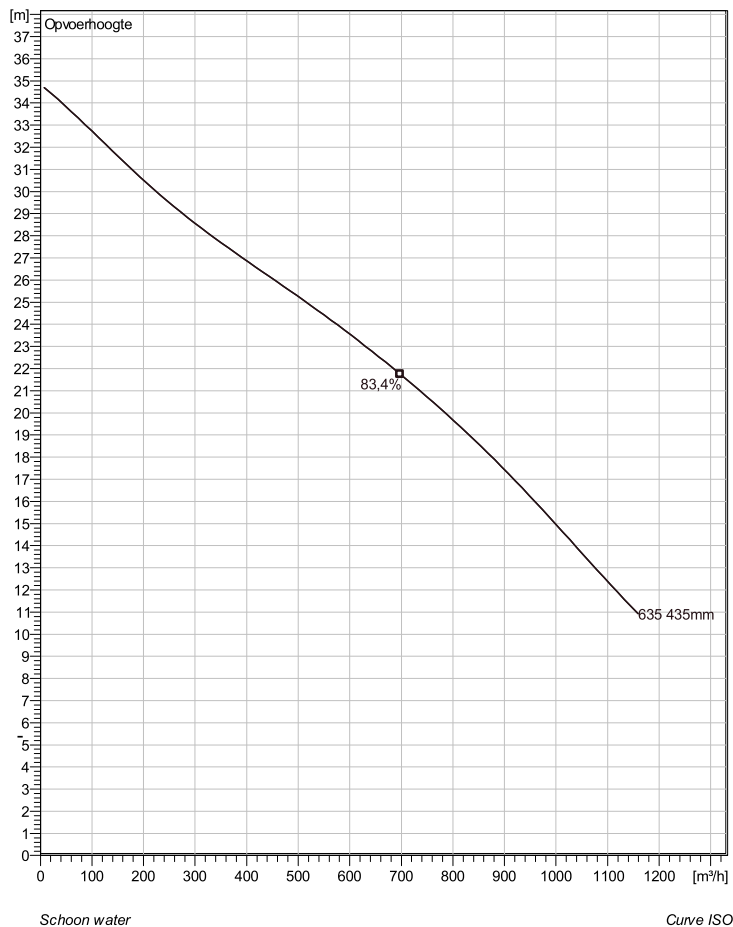

Note: Picture might not correspond to the current configuration.

General

Dompelbare pompen voorzien van verstopingsongevoeilige N-waaiers. Geschikt voor afvalwater met grotere delen zoals rioolwater, regenwater en industriële afvalwater. Materiaal gietijzer.

Impeller

Impeller material	Grey cast iron
Persaansluiting	250 mm
Diameter aanzuigzijde	250 mm
Impeller diameter	435 mm
Aantal bladen	3

Motor

Motor #	N3315.180 35-35-6AA-W 75KW standaard
Stator variant	1
Frequentie	50 Hz
Nominale spanning	400 V
Aantal polen	6
Fasen	3~
Nominaal vermogen	75 kW
Toegekende stroom	150 A
Aanloopstroom	935 A
Nominaal toerental	985 rpm
Vermogensfactor	
1/1 Load	0,79
3/4 Load	0,73
1/2 Load	0,62
Motor efficiency	
1/1 Load	91,2 %
3/4 Load	91,9 %
1/2 Load	91,7 %

Soort installatie: Semi Permanent, Nat

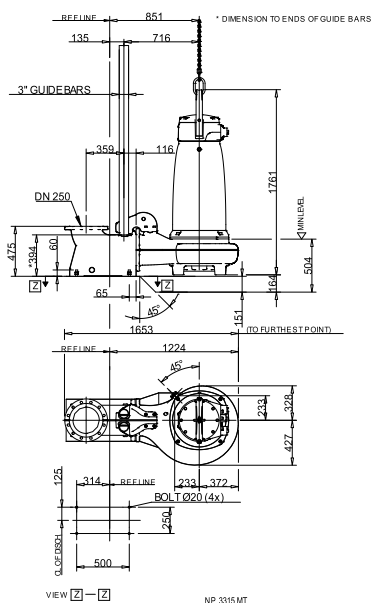

Project omschrijving	Projectnummer	Aangemaakt door:	Aangemaakt op 9/27/2018	Laatste wijziging
----------------------	---------------	------------------	----------------------------	-------------------

NP 3315 MT 3~ 635

Karakteristiek

Pomp

Persaansluiting	250 mm
Diameter aanzuigzijde	250 mm
Impeller diameter	435 mm
Aantal bladen	3

Motor

Motor #	N3315.180 35-35-6AA-W 75KW
Stator variant	1
Frequentie	50 Hz
Nominale spanning	400 V
Aantal polen	6
Fasen	3~
Nominaal vermogen	75 kW
Toegekende stroom	150 A
Aanloopstroom	935 A
Nominaal toerental	985 rpm

Vermogensfactor	
1/1 Load	0,79
3/4 Load	0,73
1/2 Load	0,62
Motor efficiency	
1/1 Load	91,2 %
3/4 Load	91,9 %
1/2 Load	91,7 %

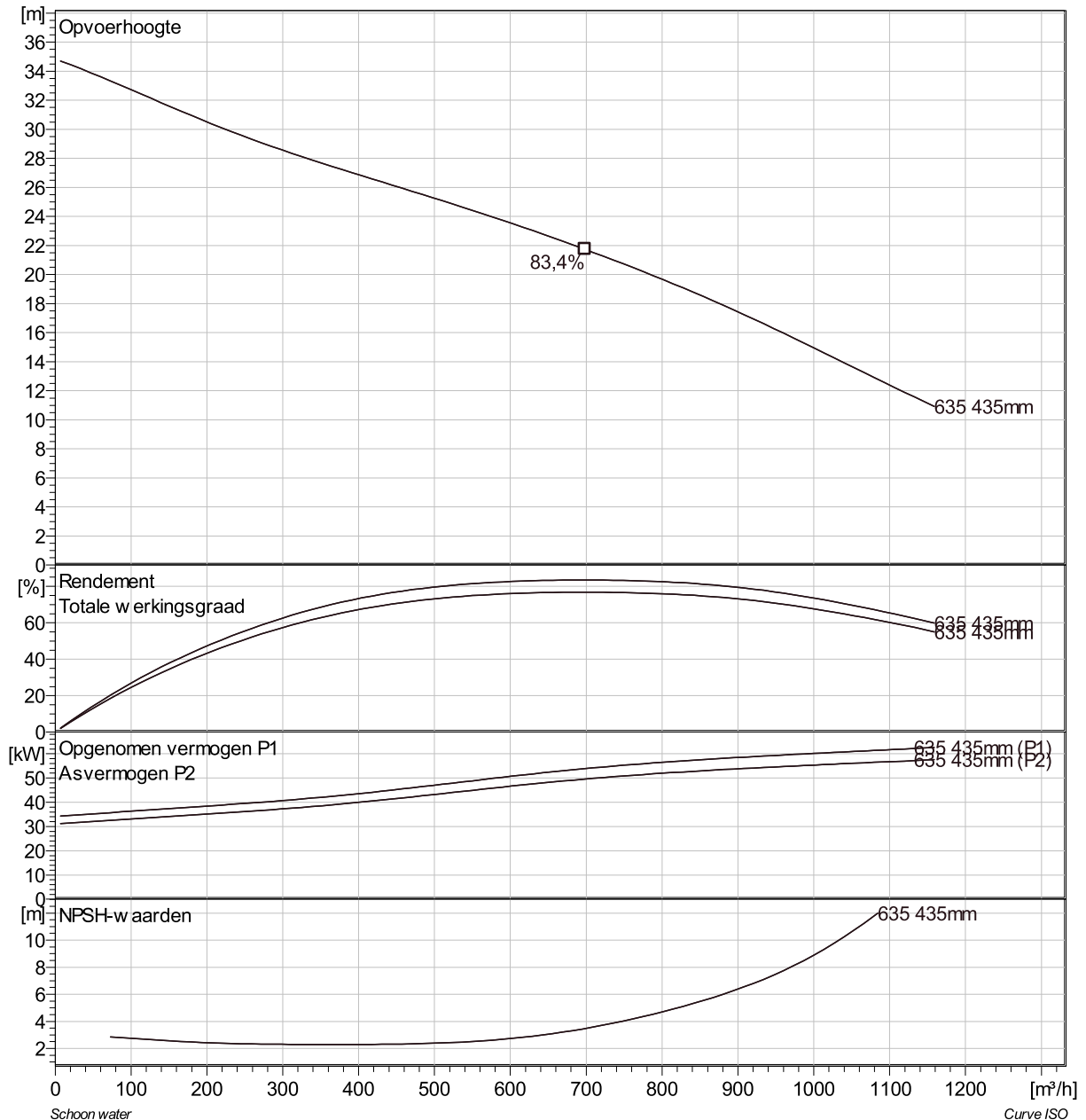

Project omschrijving	Projectnummer	Aangemaakt door:	Aangemaakt op 9/27/2018	Laatste wijziging
----------------------	---------------	------------------	----------------------------	-------------------

NP 3315 MT 3~ 635

VFD Analysis

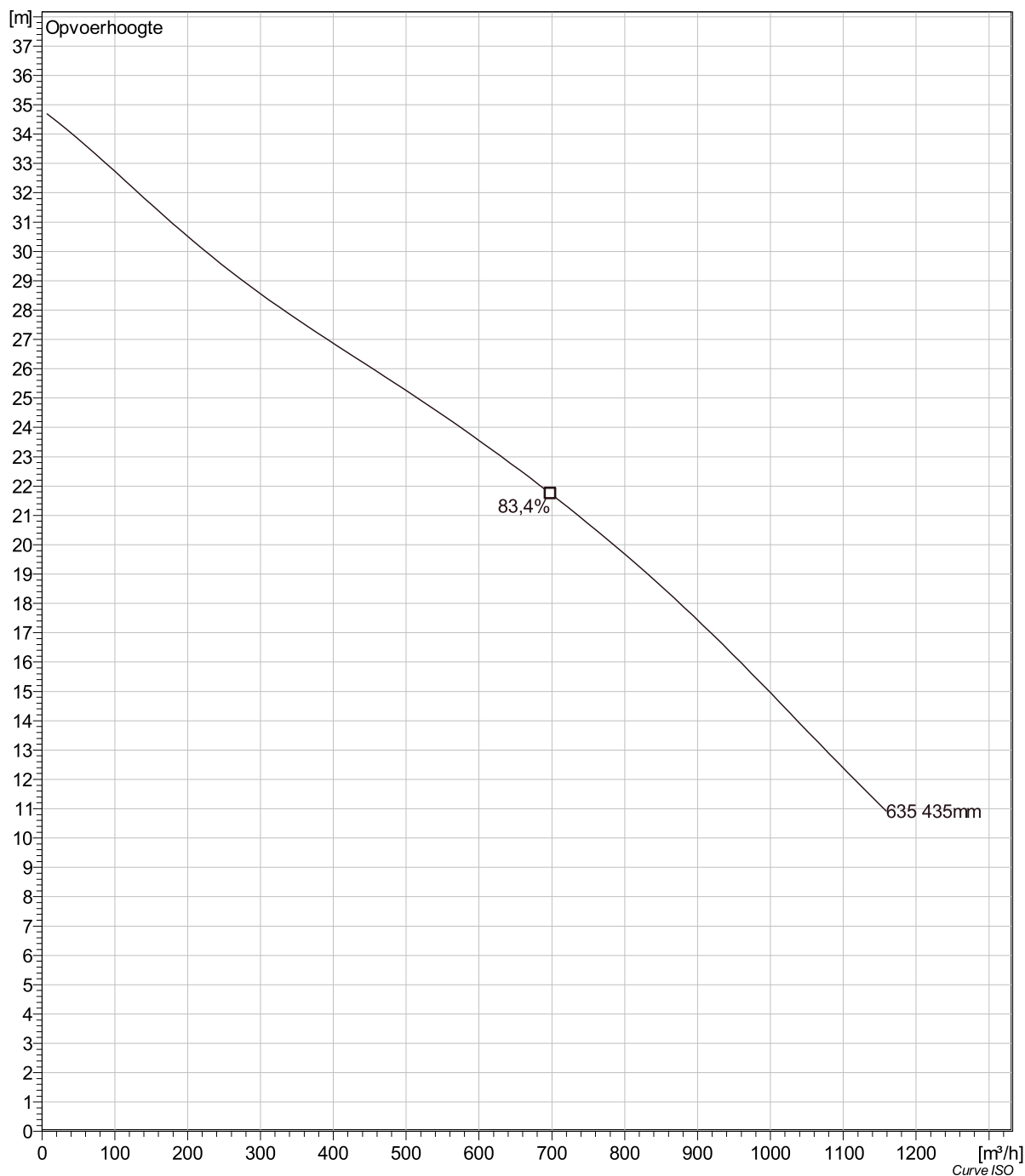

Project omschrijving	Projectnummer	Aangemaakt door:	Aangemaakt op 9/27/2018	Laatste wijziging
----------------------	---------------	------------------	----------------------------	-------------------

NP 3315 MT 3~ 635 Dimensional drawing

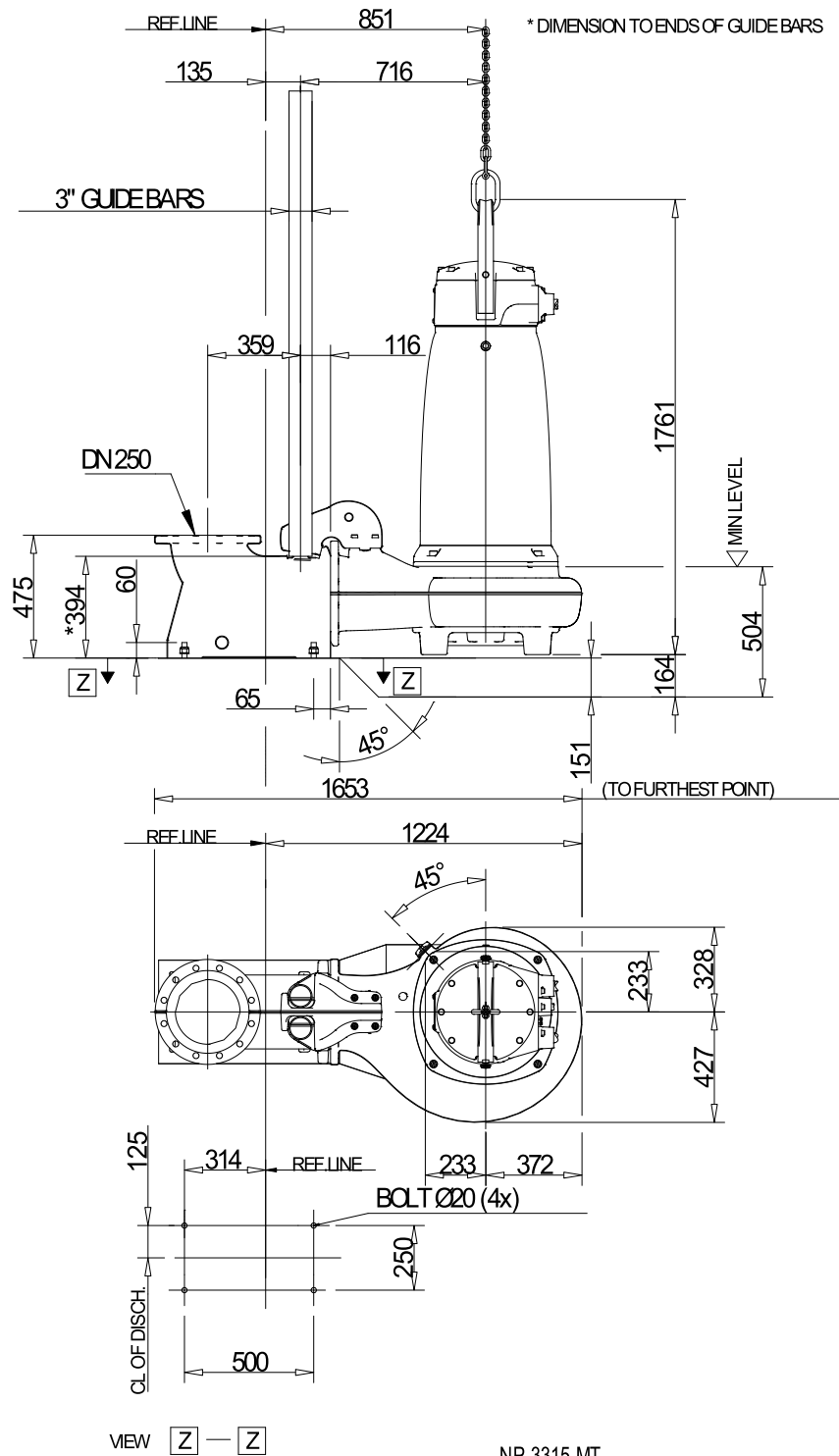

Project omschrijving	Projectnummer	Aangemaakt door:	Aangemaakt op 9/27/2018	Laatste wijziging
----------------------	---------------	------------------	----------------------------	-------------------